

Proposal Basic Information	
Proposal File No.	GUNPC/BP/0006/W14/2021
Owner Name	SARITA ORAON
Khata No	57
Plot No	85
Village Name	Karam Toli
Use	Residential
SubUse	Bungalow/ Dwelling / Non Apartment

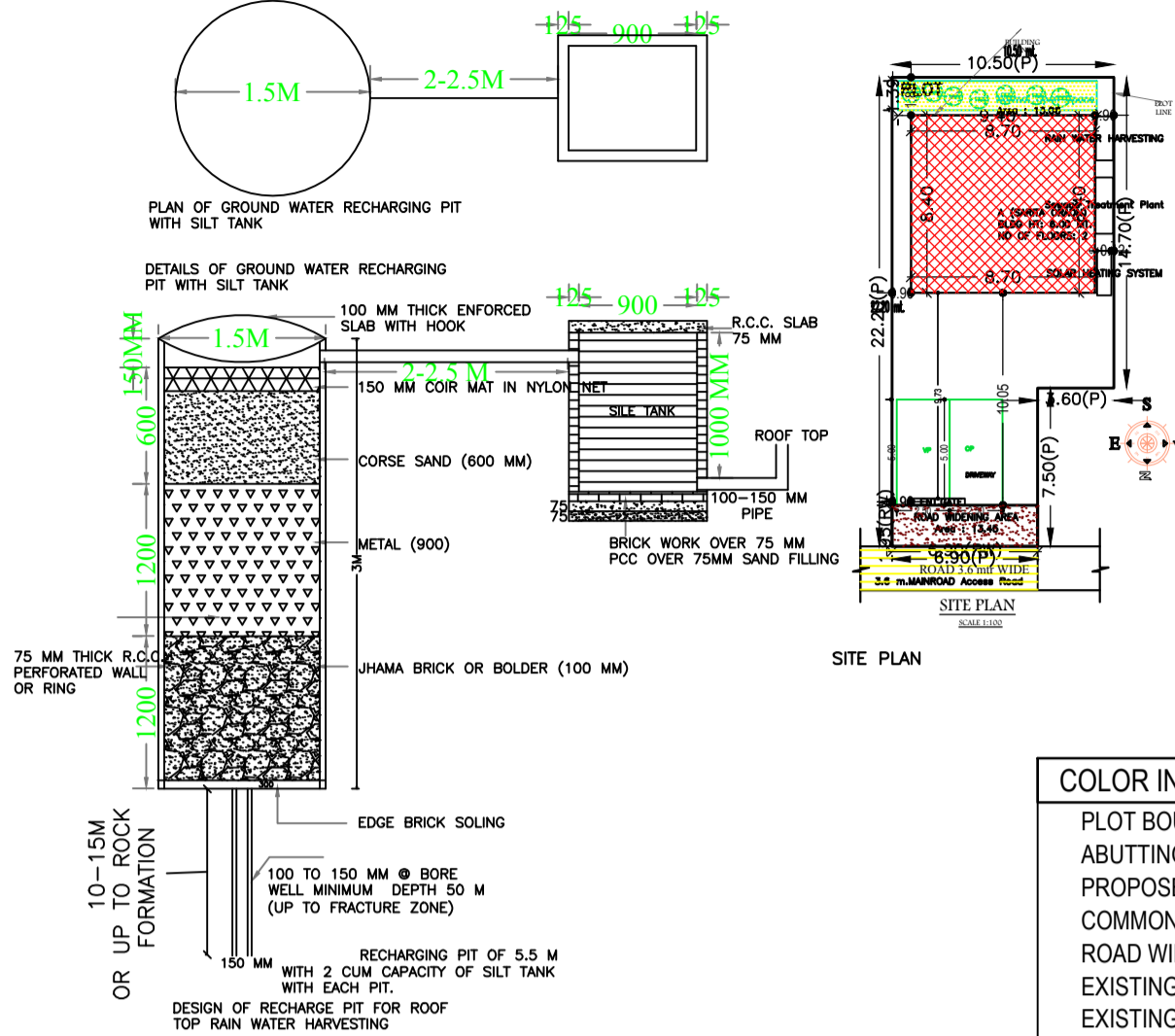

COLOR INDEX	
PLOT BOUNDARY	Black
ABUTTING ROAD	Red
PROPOSED CONSTRUCTION	Green
COMMON PLOT	Yellow
ROAD WIDENING AREA	Blue
EXISTING (To be retained)	White
EXISTING (To be demolished)	Orange

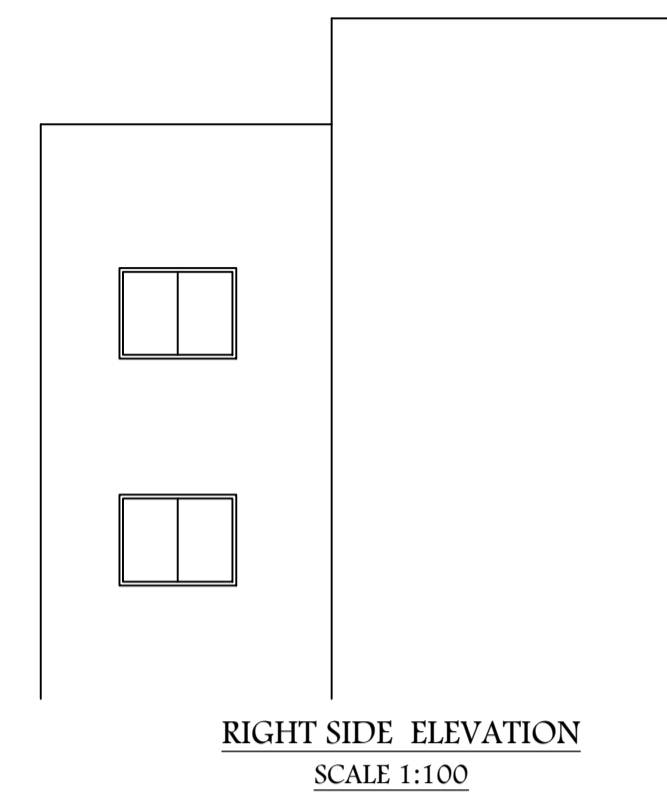
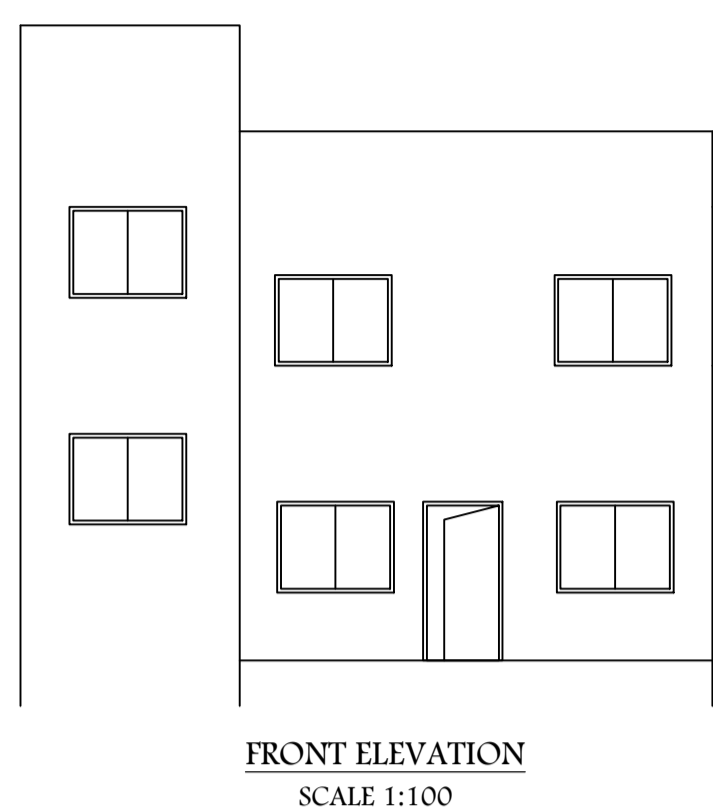
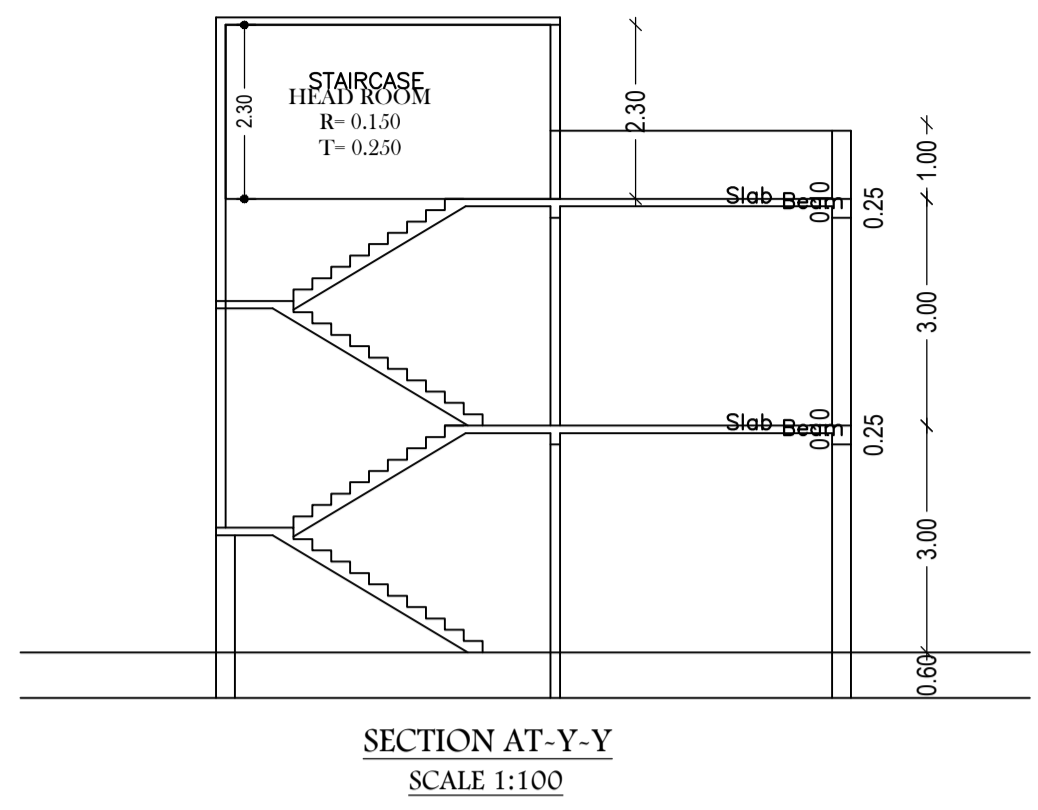
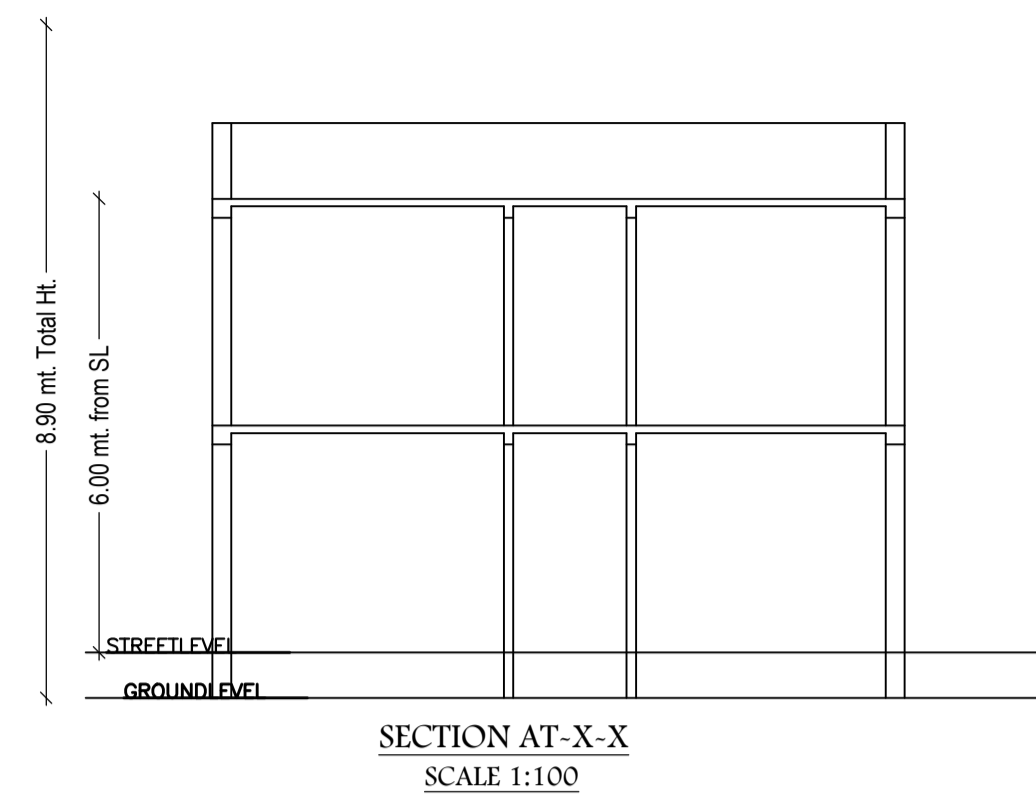
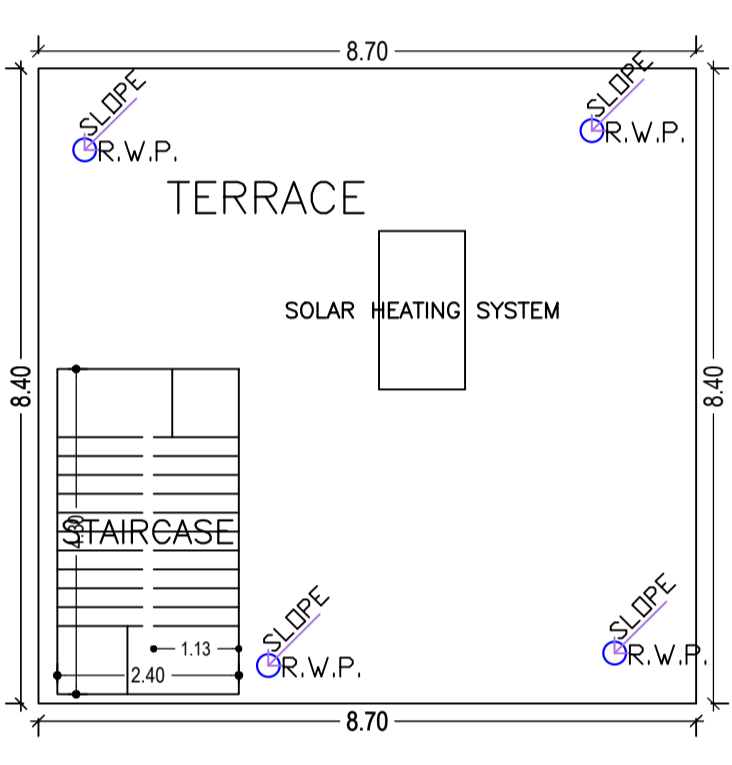
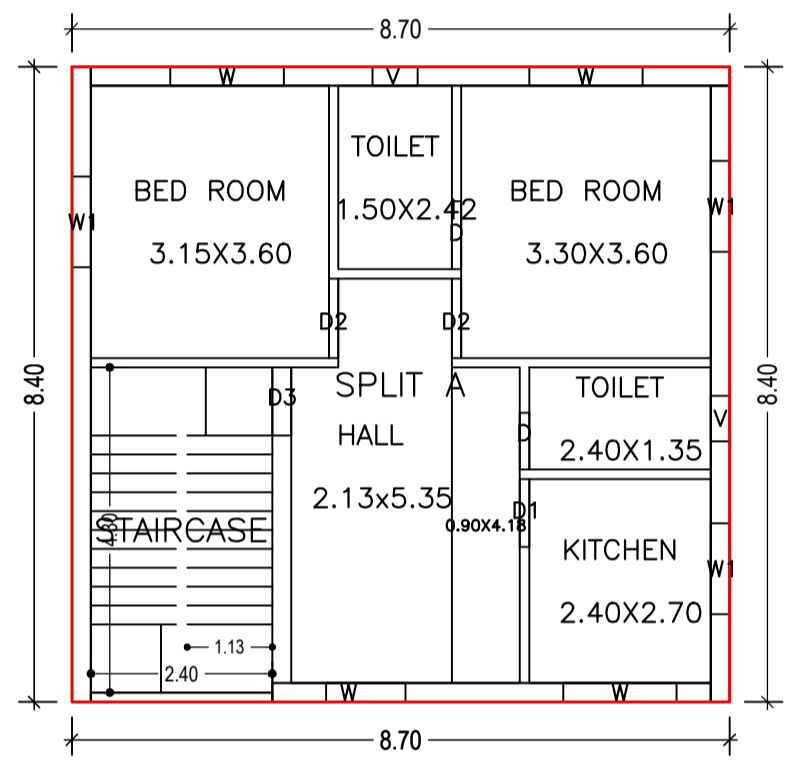
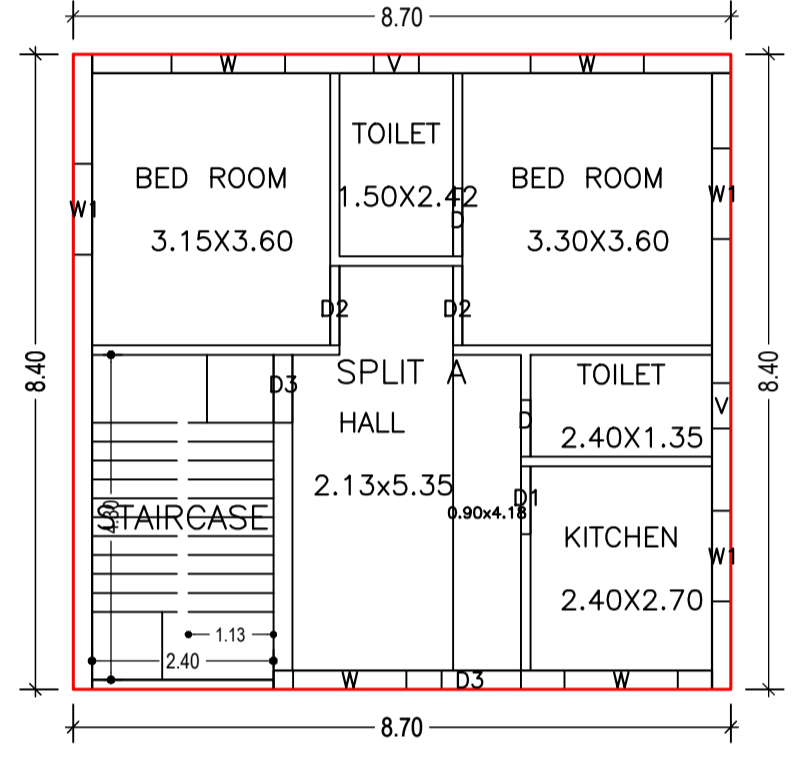

SCHEDULE OF DOOR:

BUILDING NAME	NAME	LENGTH	HEIGHT	NOS
A (SARITA ORAON)	D	0.75	2.10	02
A (SARITA ORAON)	D	0.90	2.10	02
A (SARITA ORAON)	D1	0.90	2.10	02
A (SARITA ORAON)	D3	0.90	2.10	02
A (SARITA ORAON)	D2	1.05	2.10	04
A (SARITA ORAON)	D3	1.05	2.10	01

SCHEDULE OF WINDOW/VENTILATION:

BUILDING NAME	NAME	LENGTH	HEIGHT	NOS
A (SARITA ORAON)	V	0.60	1.20	04
A (SARITA ORAON)	W	1.05	1.20	01
A (SARITA ORAON)	W1	1.20	1.20	06
A (SARITA ORAON)	W	1.50	1.20	07

Buildingwise Floor FAR Details

Floor Name	Building Name A (SARITA ORAON)		Total	
	Proposed Built Up Area (Sq.mt.)	Proposed FAR Area (Sq.mt.)	Total Proposed Built Up Area (Sq.mt.)	Total FAR Area (Sq.mt.)
Ground Floor	73.08	73.08	73.08	73.08
First Floor	73.08	73.08	73.08	73.08
Terrace Floor	0.00	0.00	0.00	0.00
Total :	146.16	146.16	146.16	146.16

FAR & Tenement Details (Table 4c-1)

Building	No. of Same Bldg	Total Built Up Area (Sq.mt.)	Proposed FAR Area (Sq.mt.)	Total FAR Area (Sq.mt.)	Total Consumed Additional FAR Area (Sq.mt.)	Trmt (No.)
A (SARITA ORAON)	1	146.16	146.16	146.16	146.16	01
Grand Total :	1	146.16	146.16	146.16	146.16	01

AREA STATEMENT GUMLA NAGAR PARISHAD		VERSION NO. : 1.0.55
PROJECT DETAIL:		VERSION DATE: 16/10/2020
Region: JHARKHAND URBAN	Plot Use: Residential	
Local Bodies: District: GUMLA	Plot SubUse: Bungalow/ Dwelling / Non Apartment	
Authority: GUMLA NAGAR PARISHAD	PlotNearby/ReligiousStructure: NA	
Inward No: GUNPC/BP/0006/W14/2021	Plot/SubPlot No: 85	
Application Type: General Proposal	North: -	
Project Type: Building Permission	South: -	
Nature of Development: New	East: -	
Location of Development Area: Old Area	West: -	
AREA DETAILS:		SQ.MT.
AREA OF PLOT (Minimum)	(A)	206.10
Deduction for NetPlot Area		
Road Widening Area		13.46
Total		13.46
NET AREA OF PLOT(Gross Plot Area - Deduction from Gross Plot area)	(A-Deductions)	192.65
Deduction for Balance Plot Area(from Gross Plot Area)		
Road Widening Area		13.46
Common Plot		13.06
Total		26.51
BALANCE AREA OF PLOT(Net Plot Area - Recreational/Amenity space)	(A-Deductions)	179.59
PLOT AREA FOR COVERAGE(Net Plot Area)	(A-Deductions)	192.65
Plot Area for FAR (Net Plot Area + RoadWidening Area)	(A-Deductions)	192.65
COVERAGE CHECK		
Permissible Coverage area ( 70.00 % )		134.85
Proposed Coverage Area ( 37.94 % )		73.08
Total Prop. Coverage Area ( 37.94 % )		73.08
Balance coverage area ( 32.06 % )		61.77
FAR CHECK		
Perm. FAR Area ( 1.50 )		289.97
Total Perm. FAR area		289.97
Residential FAR		146.16
Proposed FAR Area		146.16
Total Proposed FAR Area		146.16
Consumed FAR (Factor)		0.76
Balance FAR Area		142.81
BUILT UP AREA CHECK		
Total Proposed BuiltUp Area		146.16
ARCHITECT (Regd)	DEEPAK DIWAN	
ENGINEER (Regd)		
SUPERVISOR (Regd)		
OWNER (Regd)	SARITA ORAON	
DEVELOPMENT AUTHORITY	LOCAL BODY	

GROUND FLOOR PLAN (Proposed) (SCALE 1:100)

FIRST FLOOR PLAN (Proposed) (SCALE 1:100)

TERRACE FLOOR PLAN (SCALE 1:100)

Building :A (SARITA ORAON)

Floor Name	Total Built Up Area (Sq.mt.)	Proposed FAR Area (Sq.mt.)	Total FAR Area (Sq.mt.)	Total Consumed Additional FAR Area (Sq.mt.)	Trmt (No.)
Ground Floor	73.08	73.08	73.08	73.08	01
First Floor	73.08	73.08	73.08	73.08	00
Terrace Floor	0.00	0.00	0.00	0.00	00
Total :	146.16	146.16	146.16	146.16	01
Total Number of Same Buildings	1				
Total :	146.16	146.16	146.16	146.16	01

UnitBUA Table for Building :A (SARITA ORAON)

FLOOR	Name	UnitBUA Type	UnitBUA Area	Carpet Area	No. of Rooms	No. of Tenement
GROUND FLOOR PLAN	SPLIT A	FLAT	146.16	130.16	6	1
FIRST FLOOR PLAN	SPLIT A	FLAT	0.00	0.00	6	0
Total:	-	-	146.16	130.16	12	1

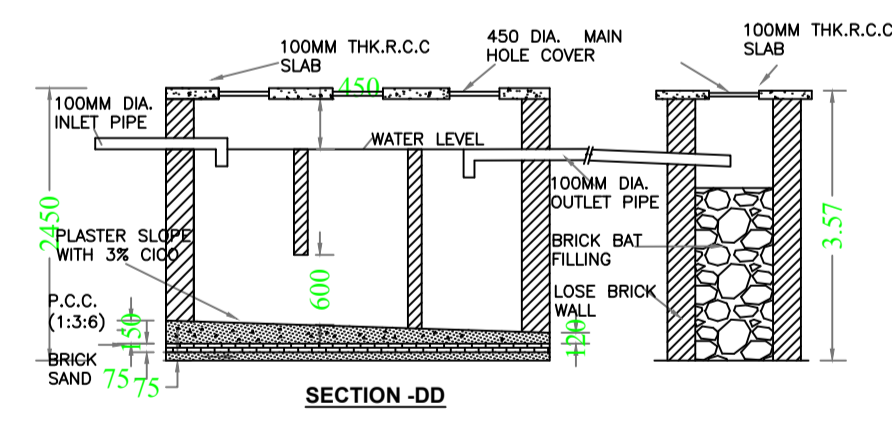
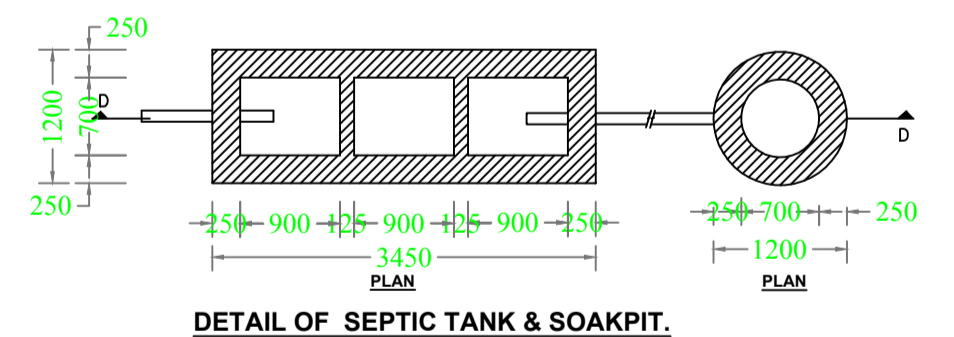
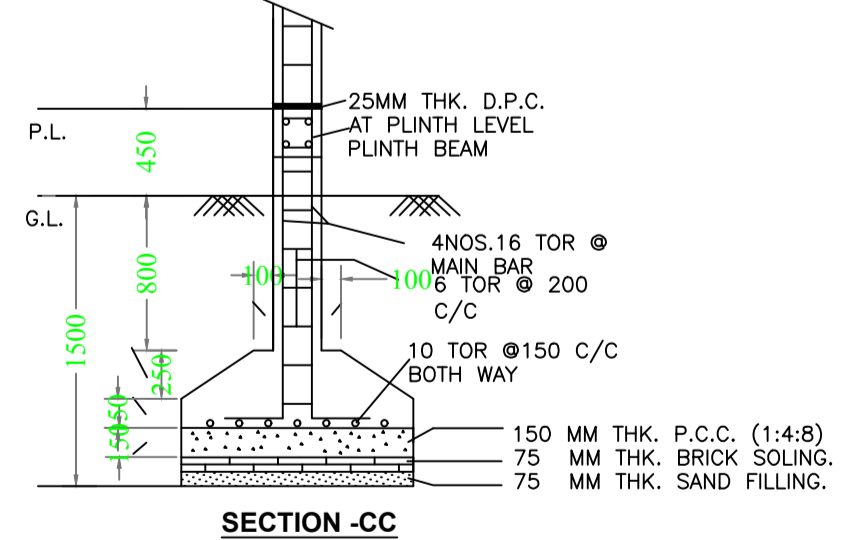
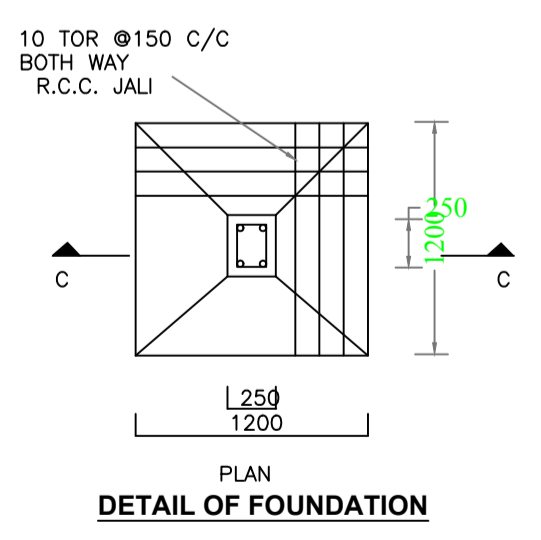

Building USE/SUBUSE Details

Building Name	Building Use	Building SubUse	Building Structure
A (SARITA ORAON)	Residential	Bungalow/ Dwelling / Non Apartment	Non-Highrise

LTP NAME AND SIGNATURE	STRUCTURAL ENG'S NAME AND SIGNATURE	BUILDER NAME AND SIGNATURE	DIGITAL SIGNATURE
DEEPAK DIWAN GUNPC/ARC/0003/2017			