

SECTION AT A-A'
(SCALE - 1:100)

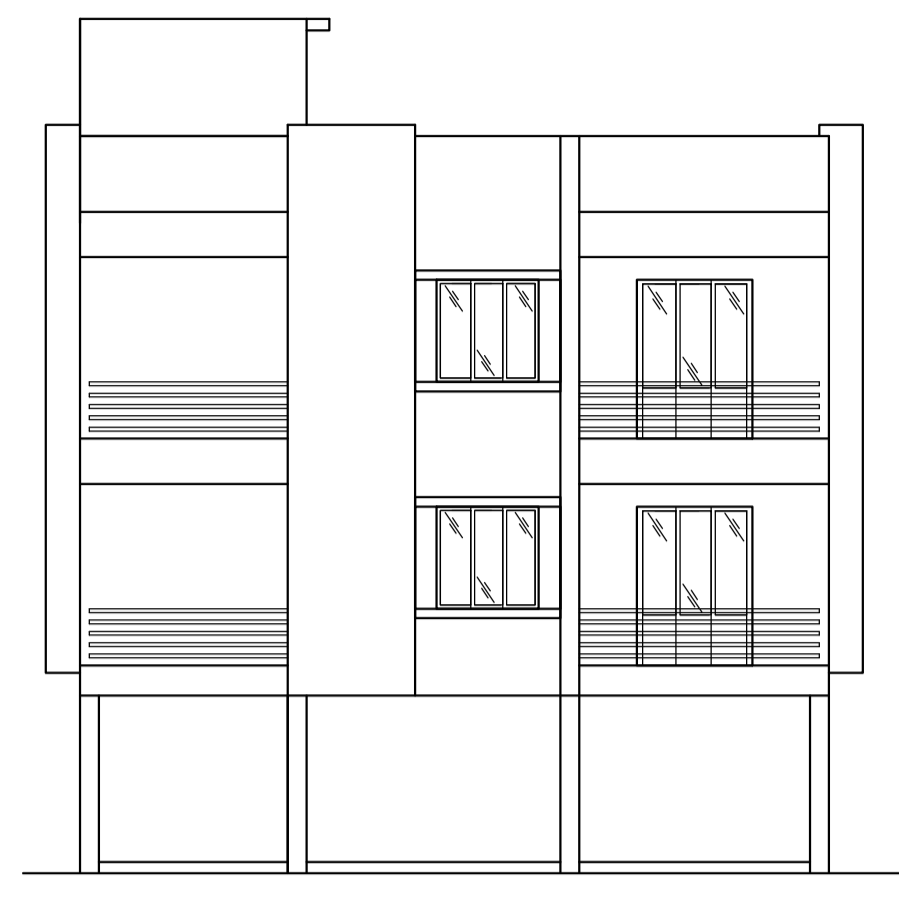

FRONT ELEVATION
(SCALE - 1:100)

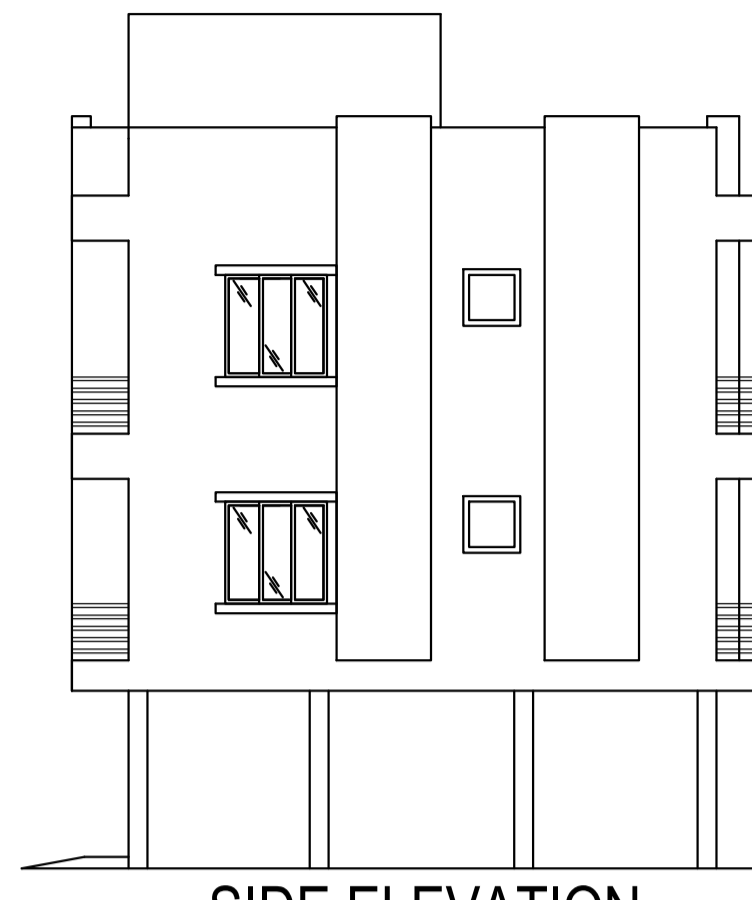

SIDE ELEVATION
(SCALE - 1:100)

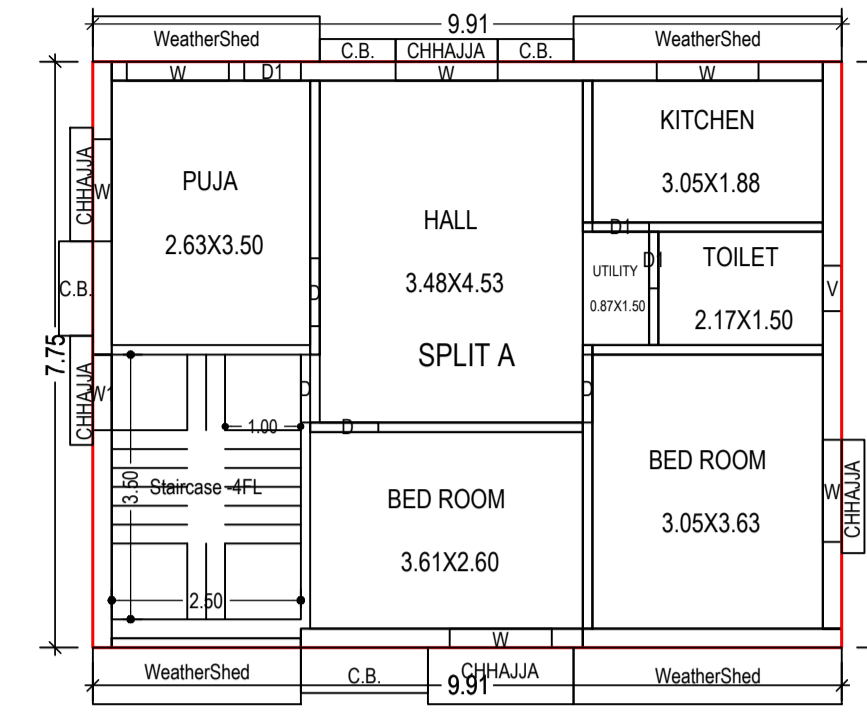

SECOND FLOOR PLAN
(Proposed)
(SCALE 1:100)

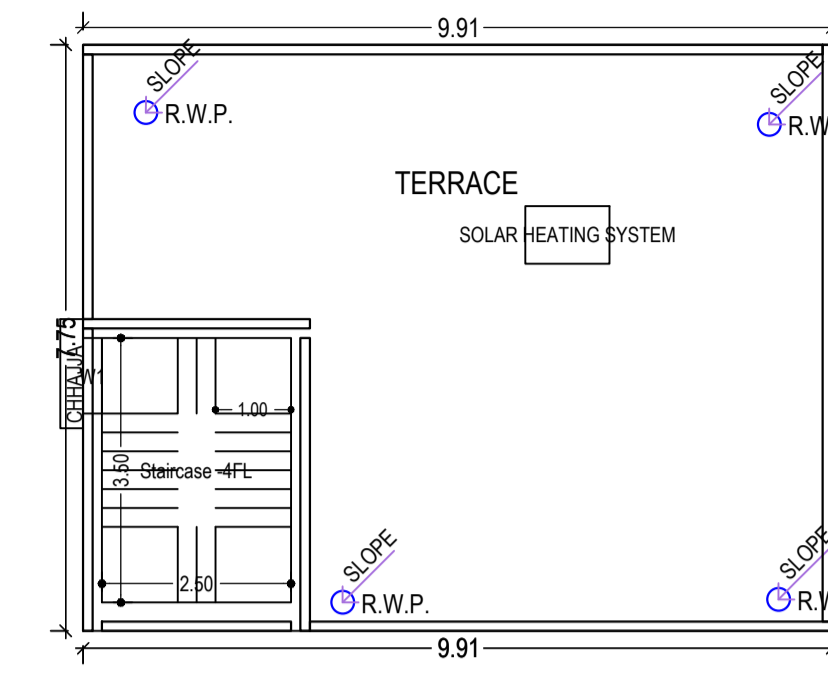

TERRACE FLOOR PLAN
(SCALE 1:100)

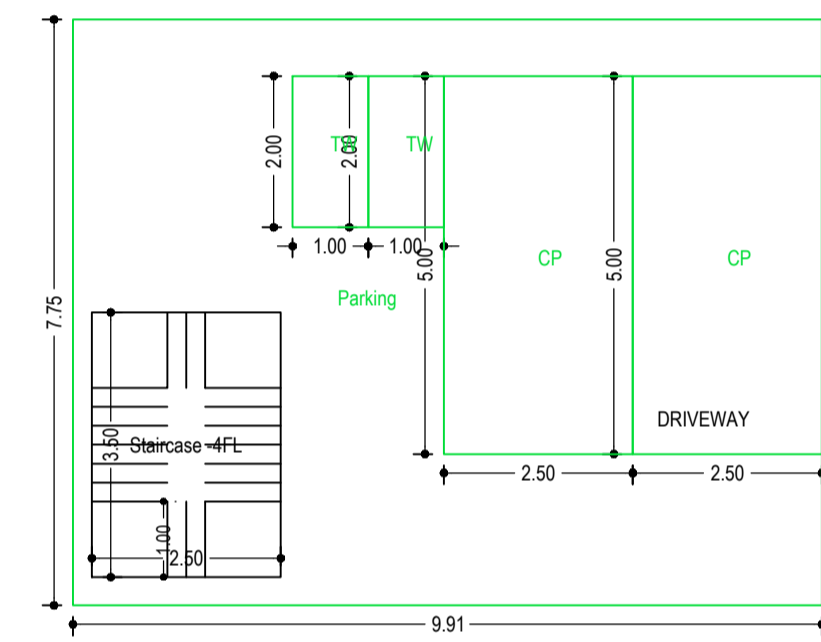

GROUND FLOOR PLAN
(Proposed)
(SCALE 1:100)

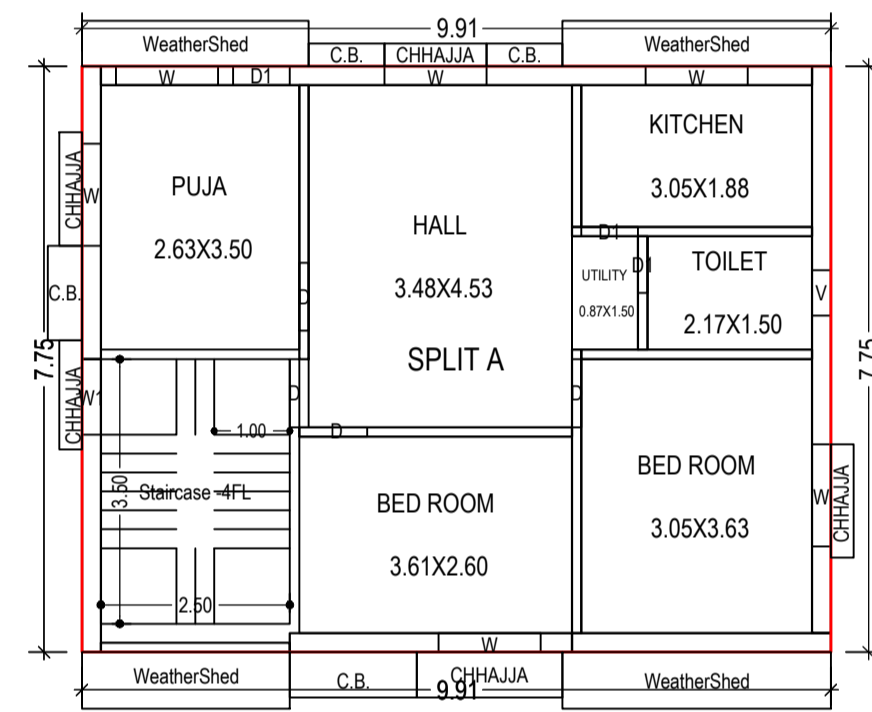

FIRST FLOOR PLAN
(Proposed)
(SCALE 1:100)

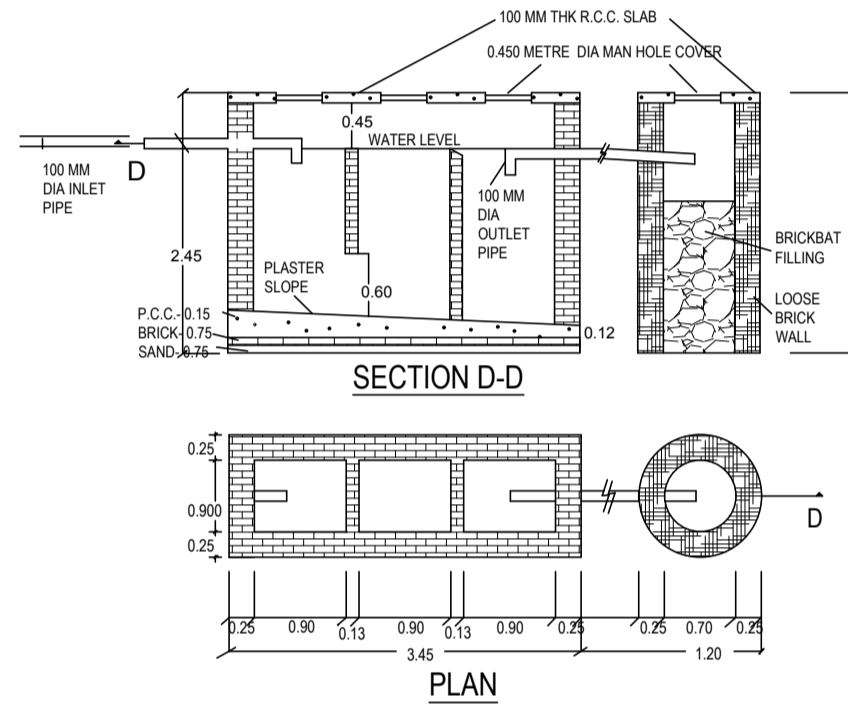

DETAILS OF SEPTIC TANK & SOAK PIT
(SCALE - N.T.S.)

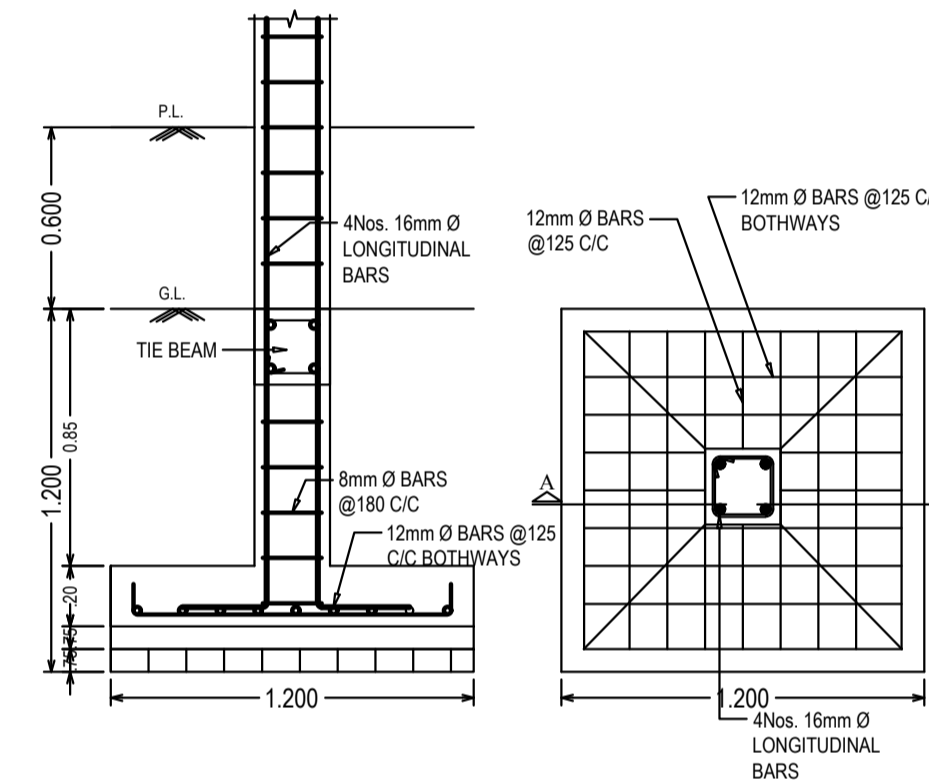

SECTION OF COLUMN
(SCALE - 1:25)

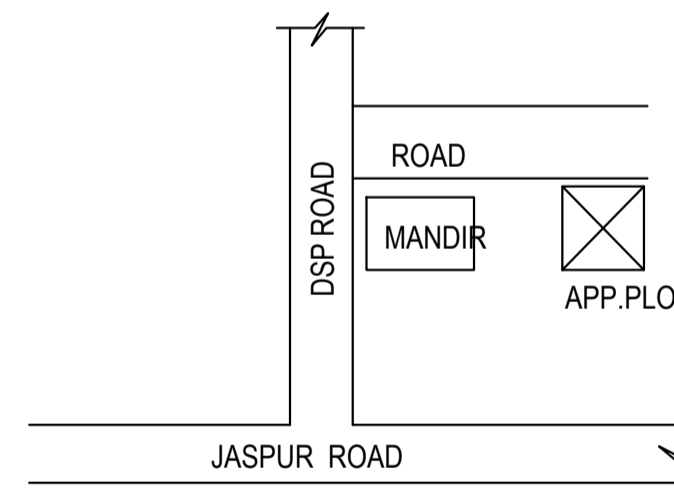

LOCATION PLAN
(SCALE - N.T.S.)

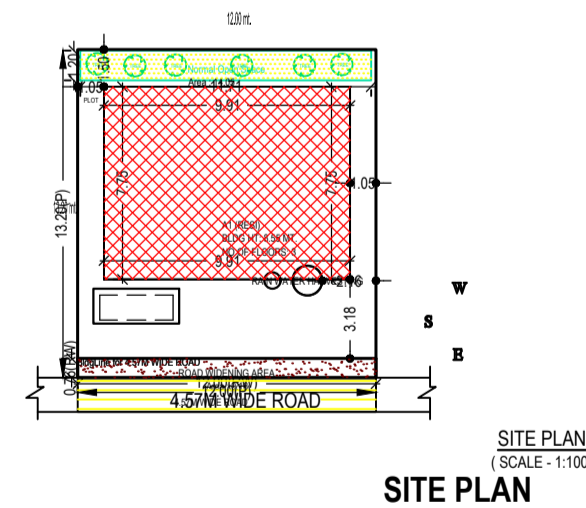

SITE PLAN
(SCALE - 1:100)

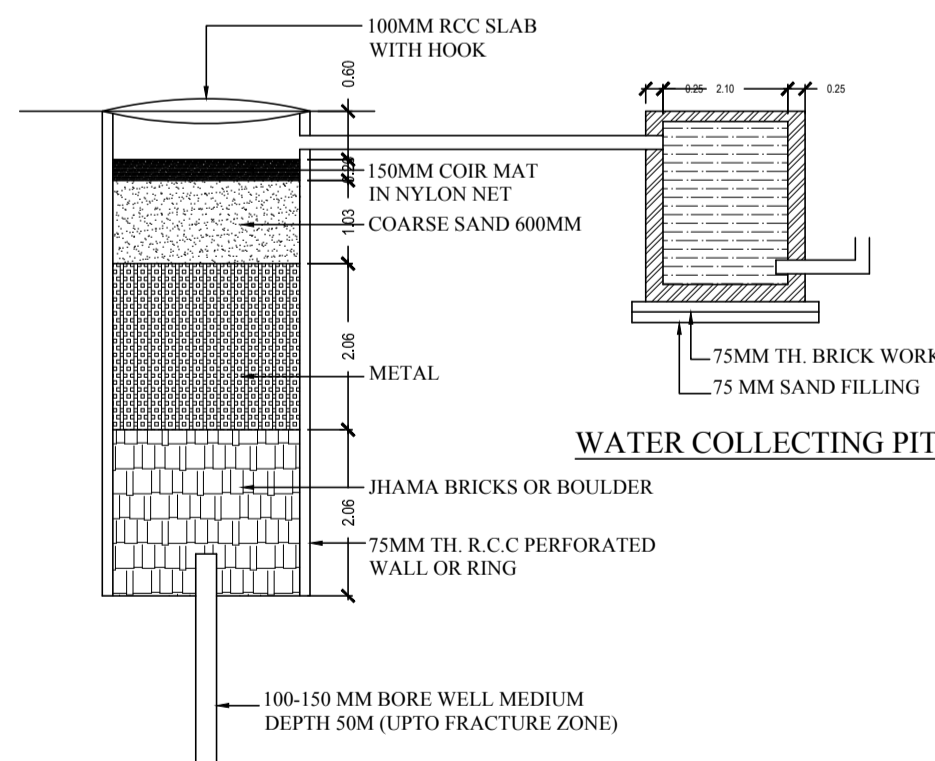

DETAILS OF RECHARGE WELL

SCHEDULE OF DOOR:

BUILDING NAME	NAME	LENGTH	HEIGHT	NOS
A1 (RESI)	D1	0.75	2.10	06
A1 (RESI)	D	0.90	2.10	06

SCHEDULE OF WINDOW/VENTILATION:

BUILDING NAME	NAME	LENGTH	HEIGHT	NOS
A1 (RESI)	V	0.60	0.75	02
A1 (RESI)	W1	1.00	1.35	03
A1 (RESI)	W	1.35	1.35	12

COLOR INDEX

PLOT BOUNDARY	Black
ABUTTING ROAD	Red
PROPOSED CONSTRUCTION	Green
COMMON PLOT	Yellow
ROAD WIDENING AREA	Orange
EXISTING (To be retained)	Blue
EXISTING (To be demolished)	Light Blue

FAR & Tenement Details (Table 4c-1)

Building	No. of Same Bldg	Total Built Up Area (Sq.mt.)	Deductions (Area in Sq.mt.)	Proposed FAR Area (Sq.mt.)	Add Area in FAR (Sq.mt.)	Total FAR Area (Sq.mt.)	Total Consumed Additional FAR Area (Sq.mt.)	Tnmt (No.)
A1 (RESI)	1	234.68	68.03	157.90	8.75	166.65	166.65	01
Grand Total :	1	234.68	68.03	157.90	8.75	166.65	166.65	01

Buildingwise Floor FAR Details

Floor Name	Building Name		Total	
	Proposed Built Up Area (Sq.mt.)	Proposed FAR Area (Sq.mt.)	Total Proposed Built Up Area (Sq.mt.)	Total FAR Area (Sq.mt.)
Ground Floor	76.78	8.75	76.78	8.75
First Floor	78.95	78.95	78.95	78.95
Second Floor	78.95	78.95	78.95	78.95
Terrace Floor	0.00	0.00	0.00	0.00
Total :	234.68	166.65	234.68	166.65

AREA STATEMENT GUMLA NAGAR PARISHAD

VERSION NO.: 1.0.53
VERSION DATE: 16/10/2020

PROJECT DETAIL:

Region: JHARKHAND URBAN LOCAL BODIES
District: GUMLA
Authority: GUMLA NAGAR PARISHAD
Inward No: GUNPC/BP/0003/W17/2021
Application Type: General Proposal
Project Type: Building Permission
Nature of Development: New
Location of Development Area: Old Area

Plot Use: Residential
Plot SubUse: Bungalow/ Dwelling / Non Apartment
PlotNearbyReligiousStructure: NA
Plot/SubPlot No: 853
North: -
South: -
East: -
West: -

UnitBUA Table for Building :A1 (RESI)

FLOOR	Name	UnitBUA Type	UnitBUA Area	Carpet Area	No. of Rooms	No. of Tenement
FIRST FLOOR PLAN	SPLIT A	FLAT	142.90	122.51	7	1
SECOND FLOOR PLAN	SPLIT A	FLAT	0.00	0.00	7	0
Total:	-	-	142.90	122.51	14	1

Building :A1 (RESI)

Floor Name	Total Built Up Area (Sq.mt.)	Deductions (Area in Sq.mt.)	Proposed FAR Area (Sq.mt.)	Add Area in FAR (Sq.mt.)	Total FAR Area (Sq.mt.)	Total Consumed Additional FAR Area (Sq.mt.)	Tnmt (No.)
Ground Floor	76.78	68.03	0.00	8.75	8.75	8.75	00
First Floor	78.95	0.00	78.95	0.00	78.95	78.95	01
Second Floor	78.95	0.00	78.95	0.00	78.95	78.95	00
Terrace Floor	0.00	0.00	0.00	0.00	0.00	0.00	00
Total :	234.68	68.03	157.90	8.75	166.65	166.65	01

Building USE/SUBUSE Details

Building Name	Building Use	Building SubUse	Building Structure
A1 (RESI)	Residential	Bungalow/ Dwelling / Non Apartment	Non-Highrise

LTP NAME AND SIGNATURE	STRUCTURAL ENG'S NAME AND SIGNATURE	BUILDER NAME AND SIGNATURE	DIGITAL SIGNATURE
DEEPAK DIWAN GUNPC/ARC/0003/2017			