

SIDE ELEVATION
SCALE 1:100

FRONT ELEVATION
SCALE 1:100

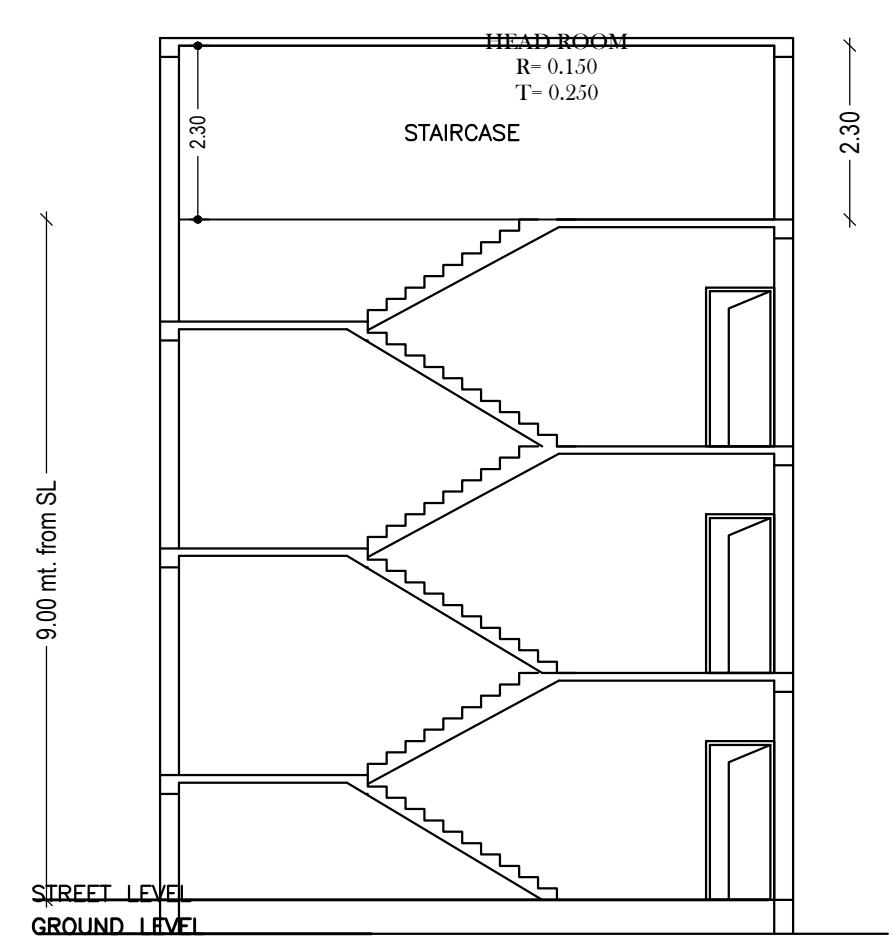

SECTION AT-XX
SCALE 1:100

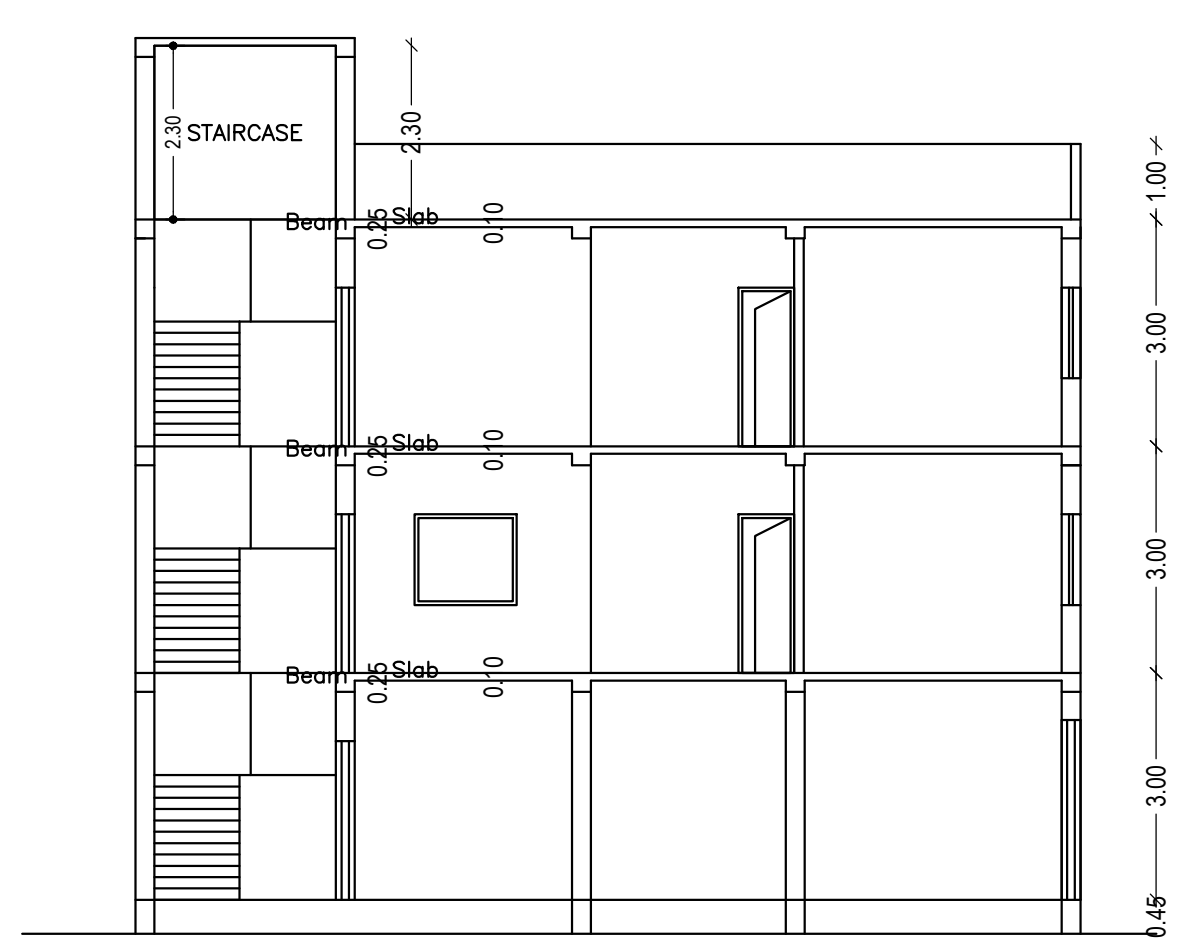

SECTION AT-YY
SCALE 1:100

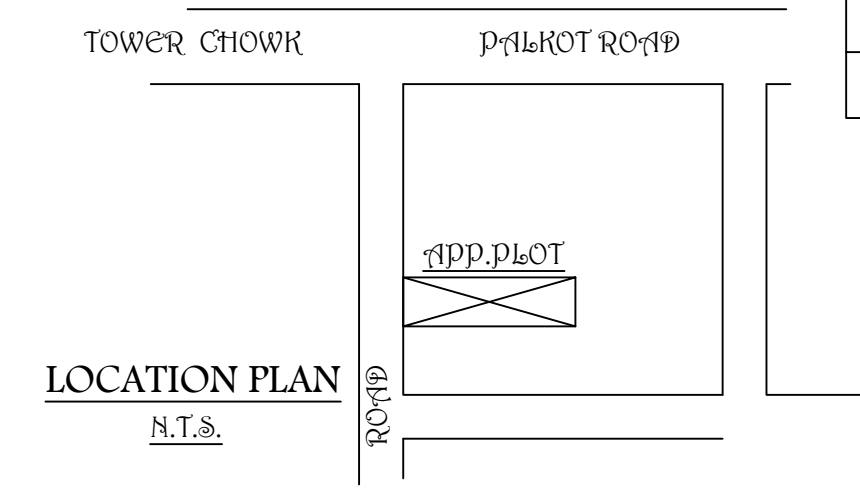

LOCATION PLAN
N.T.S.

Proposal Basic Information

Proposal File No.	GUNPC/BP/0002/W19/2021
Owner Name	SRI LALCHAND AGRAWAL AND MAHESH AGRAWAL
Khata No	430
Plot No	981
Village Name	Tower Chowk
Use	Residential
SubUse	Bungalow/ Dwelling / Non Apartment

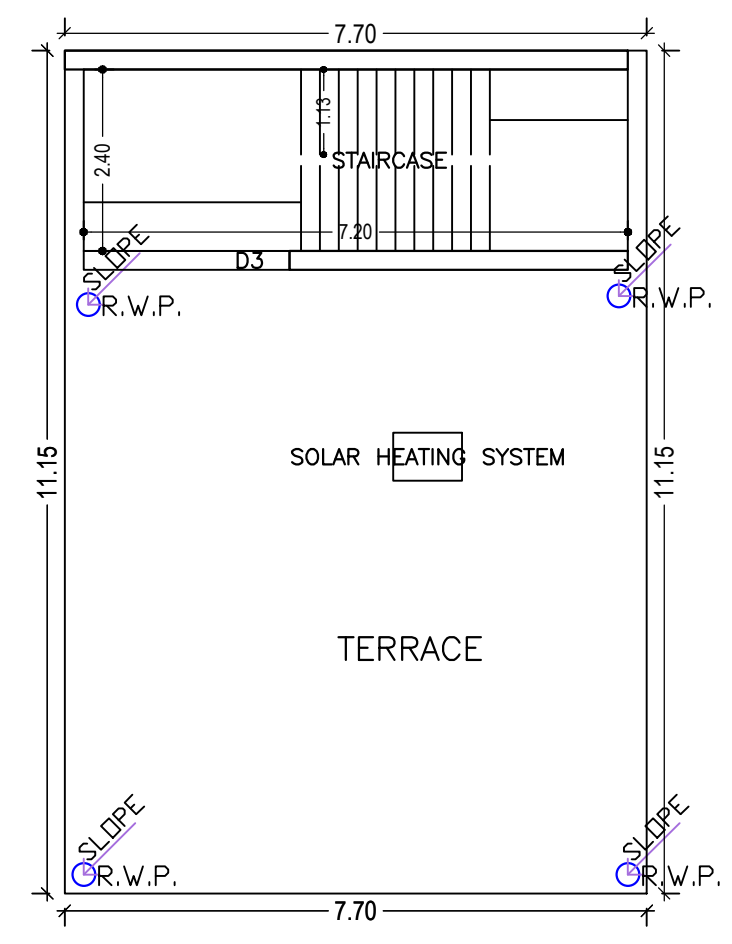

TERRACE FLOOR PLAN
(SCALE 1:100)

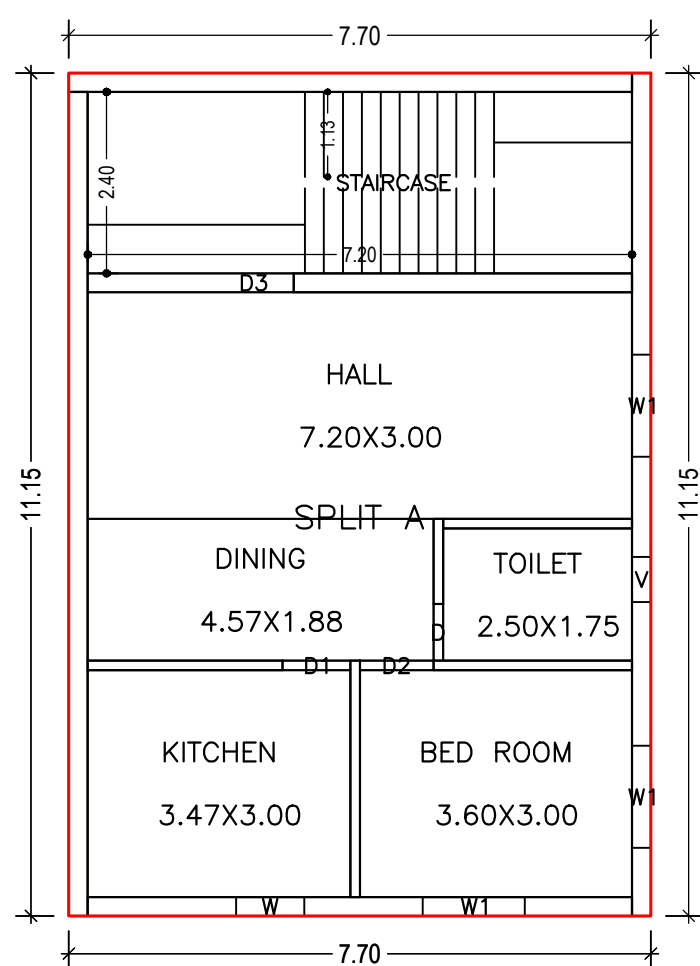

TYPICAL - 1& 2 FLOOR PLAN
(Proposed)
(SCALE 1:100)

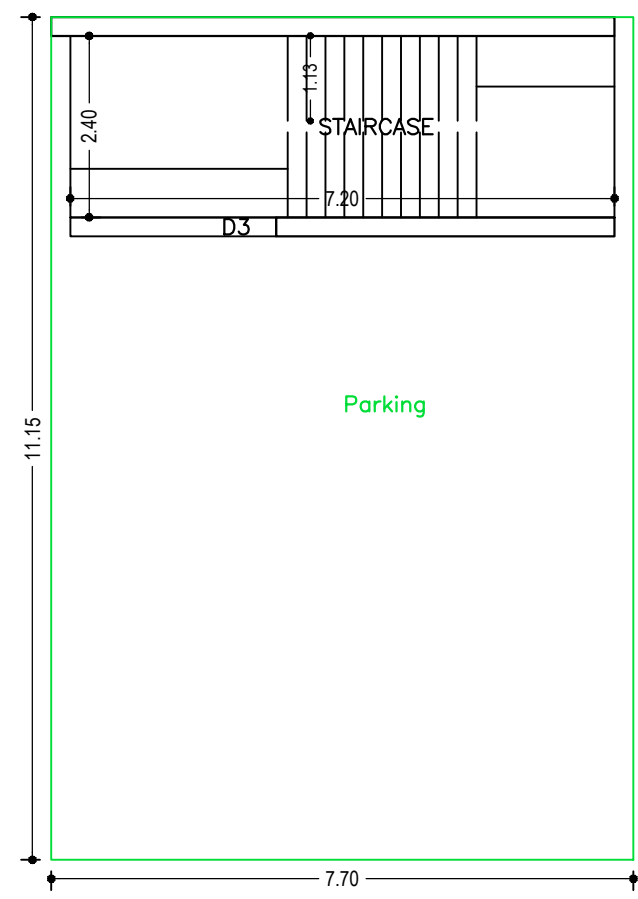

GROUND FLOOR PLAN
(SCALE 1:100)

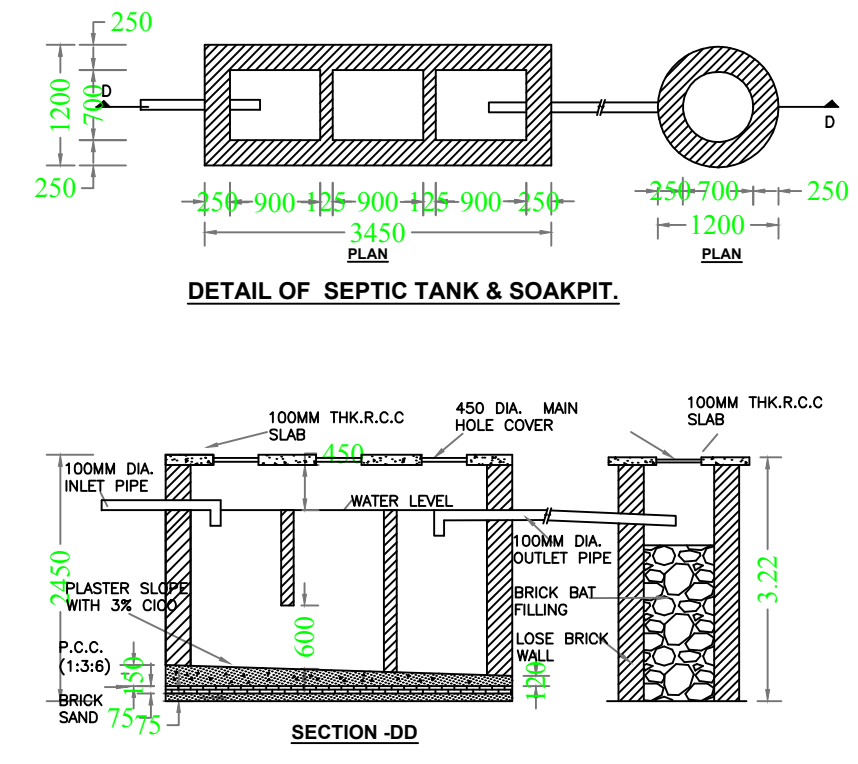

DETAIL OF SEPTIC TANK & SOAKPIT

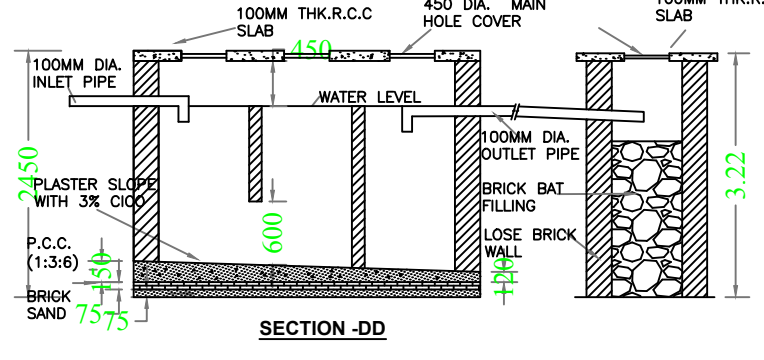

SECTION-DD

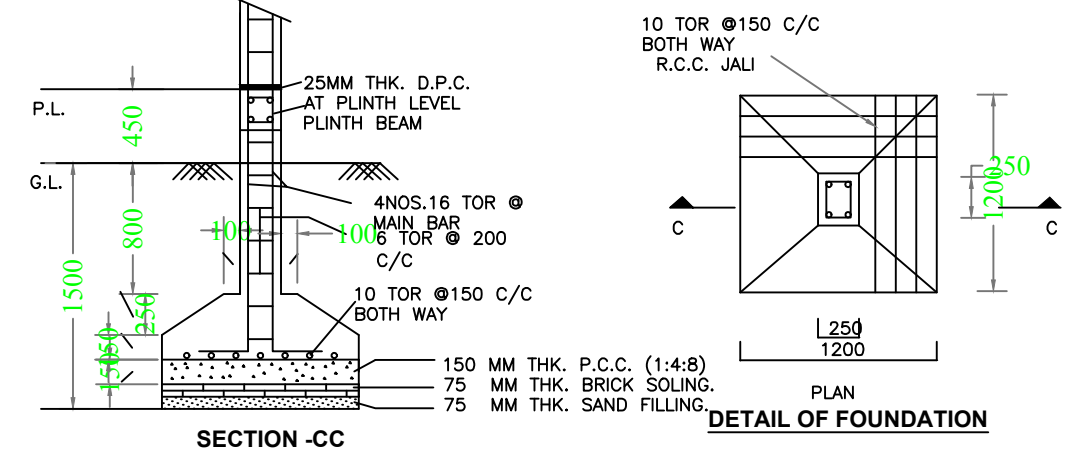

SECTION-CC

DETAIL OF FOUNDATION

Building :A (BUILDING)

Floor Name	Total Built Up Area (Sq.mt.)	Deductions (Area in Sq.mt.)		Proposed FAR Area (Sq.mt.)		Add Area in FAR (Sq.mt.)	Total FAR Area (Sq.mt.)	Total Consumed Additional FAR Area (Sq.mt.)	Trmt (No.)
		Parking	Resi.	Resi.	Stair				
Ground Floor	85.86	68.58	0.00	17.28	17.28	17.28	17.28	0.00	02
First Floor	85.86	0.00	85.86	0.00	85.86	85.86	85.86	0.00	01
Second Floor	85.86	0.00	85.86	0.00	85.86	85.86	85.86	0.00	01
Terrace Floor	0.00	0.00	0.00	0.00	0.00	0.00	0.00	0.00	00
Total :	257.58	68.58	171.72	17.28	189.00	189.00	189.00	0.00	02

UnitBUA Table for Building :A (BUILDING)

FLOOR	Name	UnitBUA Type	UnitBUA Area	Carpet Area	No. of Rooms	No. of Tenement
TYPICAL - 1& 2 FLOOR PLAN	SPLIT A	FLAT	85.86	74.07	5	2
Total:	-	-	171.71	148.14	10	2

Building USE/SUBUSE Details

Building Name	Building Use	Building SubUse	Building Structure
A (BUILDING)	Residential	Bungalow/ Dwelling / Non Apartment	Non-Highrise

SCHEDULE OF DOOR:

BUILDING NAME	NAME	LENGTH	HEIGHT	NOS
A (BUILDING)	D	0.75	2.10	02
A (BUILDING)	D1	0.90	2.10	02
A (BUILDING)	D2	0.98	2.10	02
A (BUILDING)	D3	2.73	2.10	02

SCHEDULE OF WINDOW/VENTILATION:

BUILDING NAME	NAME	LENGTH	HEIGHT	NOS
A (BUILDING)	V	0.60	0.60	02
A (BUILDING)	W	0.90	1.20	02
A (BUILDING)	W1	1.35	1.20	06

COLOR INDEX

Color	Description
Black	PLOT BOUNDARY
Red	ABUTTING ROAD
Green	PROPOSED CONSTRUCTION
Blue	COMMON PLOT
Yellow	ROAD WIDENING AREA
Orange	EXISTING (To be retained)
Purple	EXISTING (To be demolished)

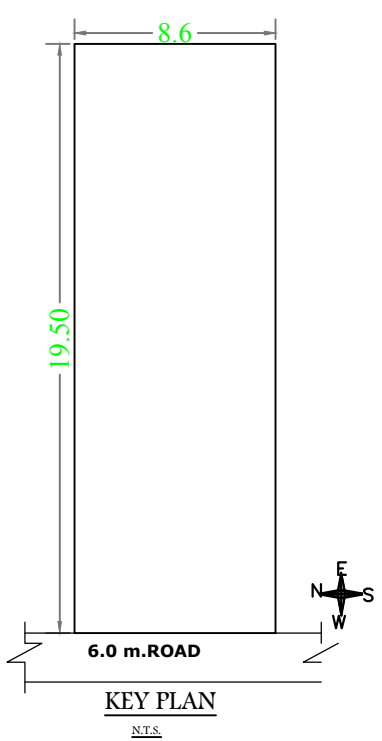

KEY PLAN

FAR & Tenement Details (Table 4c-1)

Building	No. of Same Bldg	Total Built Up Area (Sq.mt.)	Deductions (Area in Sq.mt.)	Proposed FAR Area (Sq.mt.)	Add Area in FAR (Sq.mt.)	Total FAR Area (Sq.mt.)	Total Consumed Additional FAR Area (Sq.mt.)	Trmt (No.)
A (BUILDING)	1	257.58	68.58	171.72	17.28	189.00	189.00	02
Grand Total :	1	257.58	68.58	171.72	17.28	189.00	189.00	02

Buildingwise Floor FAR Details

Floor Name	Building Name A (BUILDING)		Total	
	Proposed Built Up Area (Sq.mt.)	Proposed FAR Area (Sq.mt.)	Total Proposed Built Up Area (Sq.mt.)	Total FAR Area (Sq.mt.)
Ground Floor	85.86	17.28	85.86	17.28
First Floor	85.86	85.86	85.86	85.86
Second Floor	85.86	85.86	85.86	85.86
Terrace Floor	0.00	0.00	0.00	0.00
Total :	257.58	189.00	257.58	189.00

AREA STATEMENT GUMLA NAGAR PARISHAD		VERSION NO.: 1.0.55
PROJECT DETAIL:		VERSION DATE: 16/10/2020
Region: JHARKHAND URBAN	Plot Use: Residential	
District: GUMLA	Plot SubUse: Bungalow/ Dwelling / Non Apartment	
Authority: GUMLA NAGAR PARISHAD	PlotNearbyReligiousStructure: NA	
Inward No: GUNPC/BP/0002/W19/2021	Plot/SubPlot No: 981	
Application Type: General Proposal	North: -	
Project Type: Building Permission	South: -	
Nature of Development: New	East: -	
Location of Development Area: Old Area	West: -	
AREA DETAILS:		SQ.MT.
AREA OF PLOT (Minimum)	(A)	162.50
Deduction for NetPlot Area		
Road Widening Area		0.43
Total		0.43
NET AREA OF PLOT(Gross Plot Area - Deduction from Gross Plot area)	(A-Deductions)	162.07
Deduction for Balance Plot Area(from Gross Plot Area)		
Road Widening Area		0.43
Common Plot		8.59
Total		9.02
BALANCE AREA OF PLOT(Net Plot Area - Recreational/Amenity space)	(A-Deductions)	153.48
PLOT AREA FOR COVERAGE(Net Plot Area)	(A-Deductions)	162.07
Plot Area for FAR (Net Plot Area + RoadWidening Area)	(A-Deductions)	162.07
COVERAGE CHECK		
Permissible Coverage area (70.00 %)		113.45
Proposed Coverage Area (52.98 %)		85.86
Total Prop. Coverage Area (52.98 %)		85.86
Balance coverage area (17.02 %)		27.59
FAR CHECK		
Perm. FAR Area (1.80)		291.73
Total Perm. FAR area		291.73
Residential FAR		171.71
Proposed FAR		189.99
Total Proposed FAR Area		189.99
Consumed FAR (Factor)		1.17
Balance FAR Area		102.74
BUILT UP AREA CHECK		
Total Proposed BuiltUp Area		257.58
ARCHITECT (Regd)	DEEPAK DIWAN	
ENGINEER (Regd)		
SUPERVISOR (Regd)		
OWNER (Regd)	SRI LALCHAND AGRAWAL AND MAHESH AGRAWAL	
DEVELOPMENT AUTHORITY		LOCAL BODY

Required Parking (Table 7a)

Building Name	Type	SubUse	Area (Sq.mt.)	Units		Car		Visitors Car			
				Reqd.	Prop.	Reqd./Unit	Prop.	Reqd./Unit	Reqd.	Prop.	
A (BUILDING)	Residential	Bungalow/ Dwelling / Non Apartment	> 0	1	2.00	1	2	-	-	-	-
Total :	-	-	> 0	1	2.00	-	-	1	1	-	-

Parking Check (Table 7b)

Vehicle Type	Reqd.		Prop.	
	No.	Area	No.	Area
Car	-	-	2	25.00
Two Stack Car	-	-	2	25.00
Total Car	2	25.00	4	50.00
Visitor's Car Parking	-	-	1	12.50
Total Visitor Parking	1	12.50	1	12.50
Other Parking	-	-	-	69.14
Total	-	37.50	-	131.64

LTP NAME AND SIGNATURE	STRUCTURAL ENG'S NAME AND SIGNATURE	BUILDER NAME AND SIGNATURE	DIGITAL SIGNATURE
DEEPAK DIWAN GUNPC/ARC/0003/2017			