

LOWER GROUND FLOOR PLAN

GROUND FLOOR PLAN

TYPICAL-FIRST & SECOND FLOOR PLAN

THIRD FLOOR PLAN

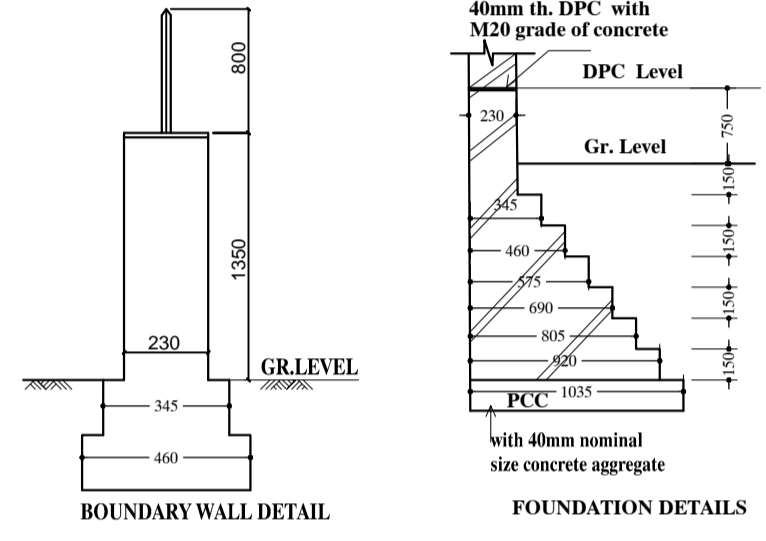
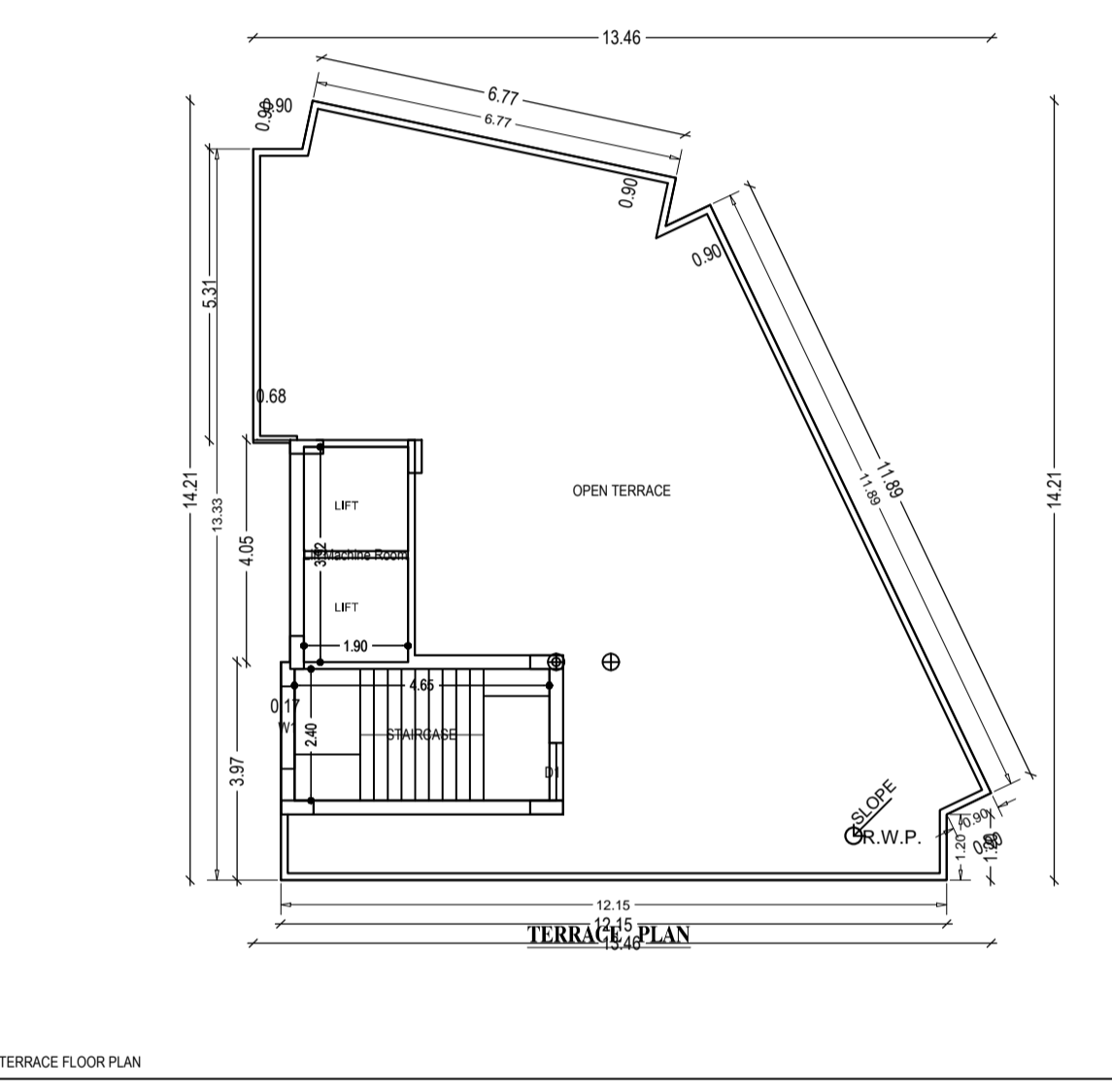
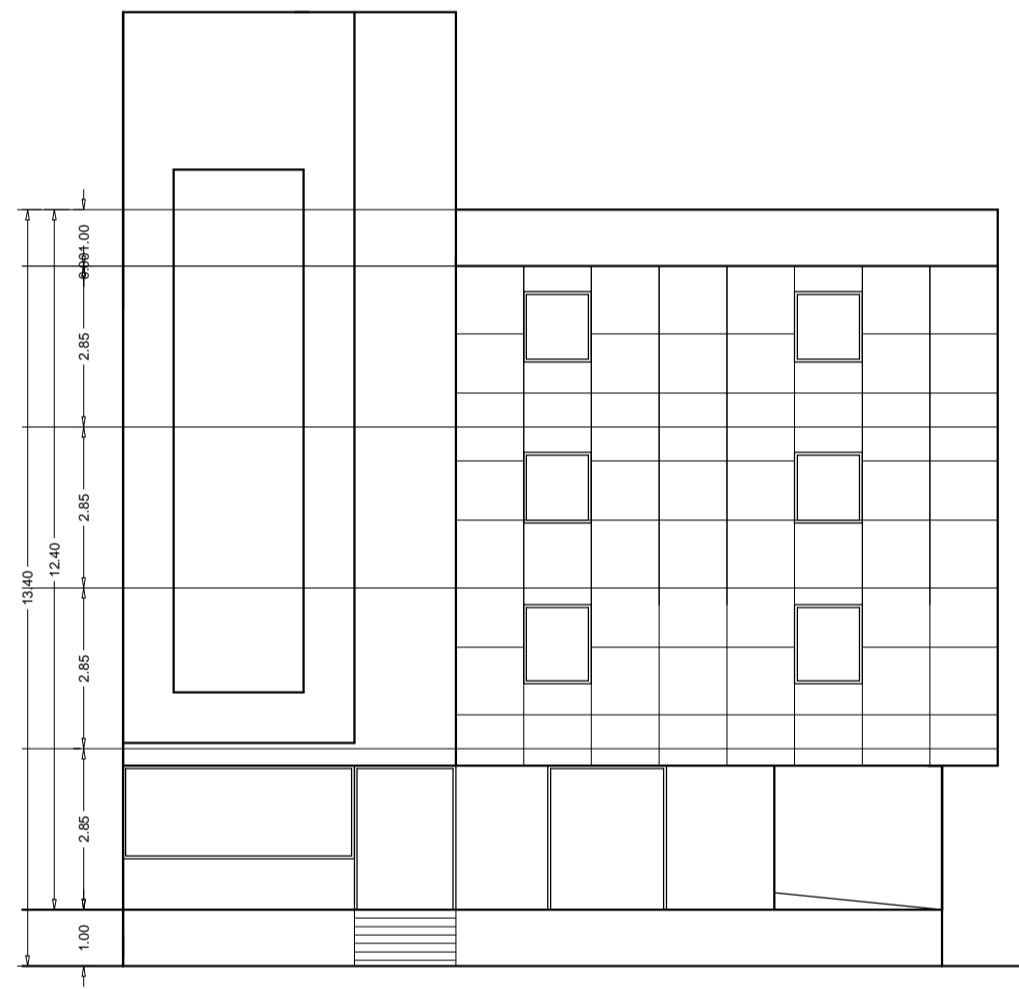
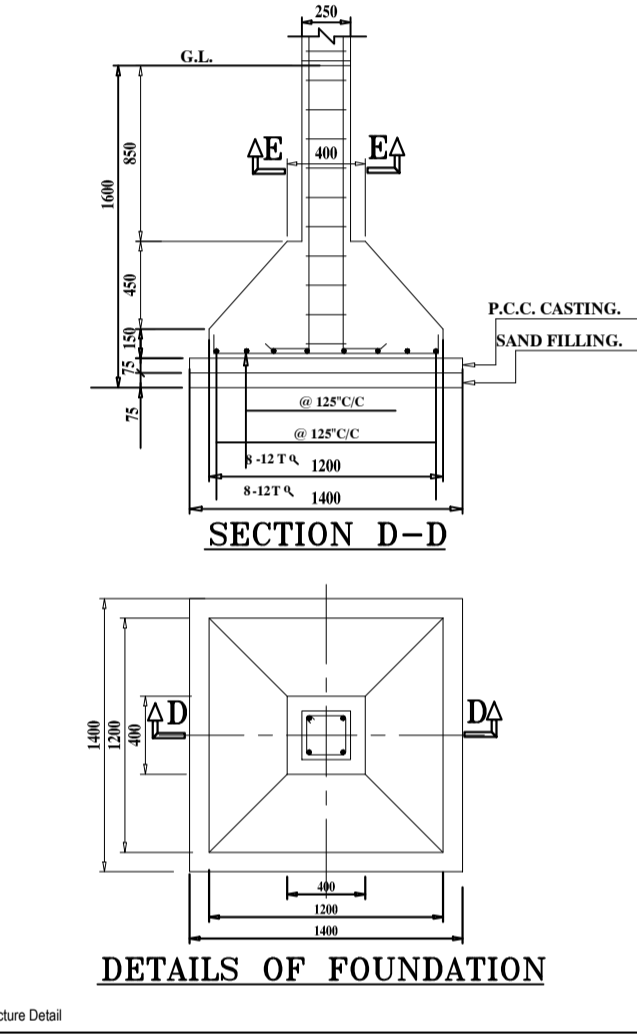
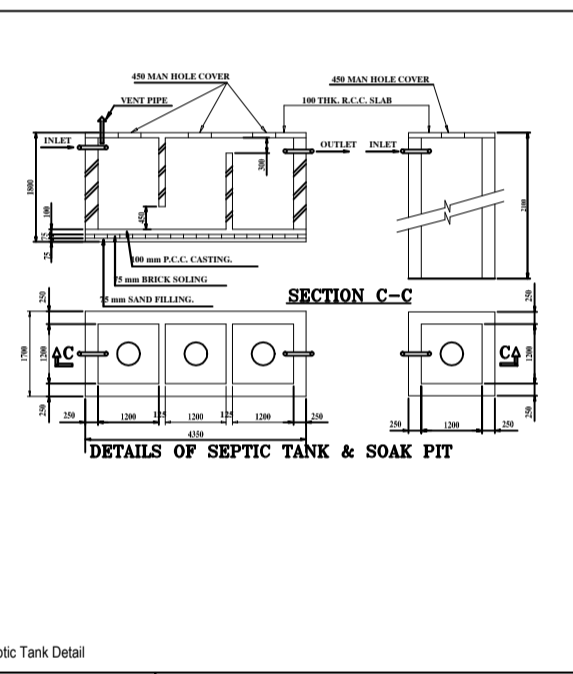
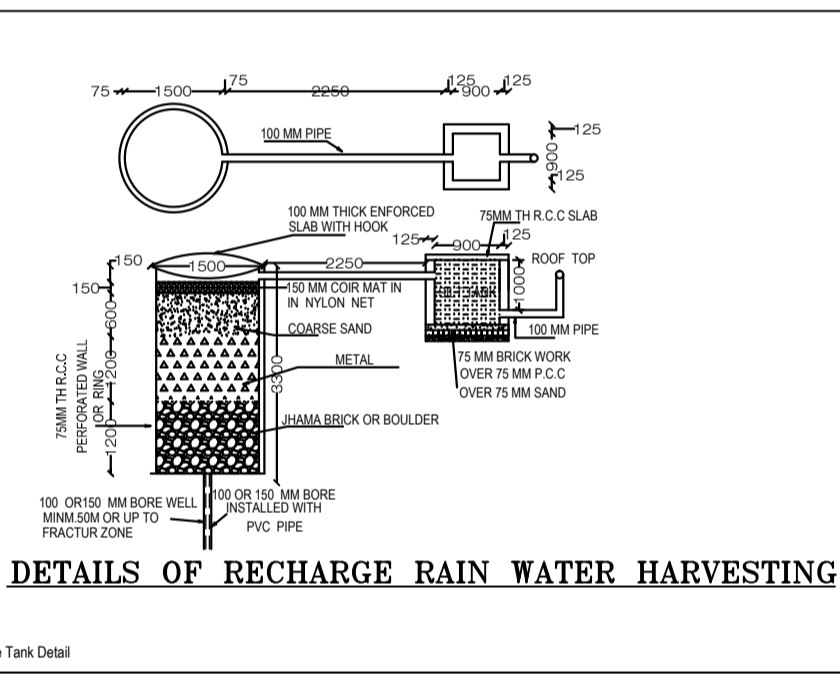

- SPECIFICATIONS:-**
- 1) FOUNDATION- R.C.C COLUMN STRUCTURE.
 - 2) WALLS- 1st. CLASS BRICK WORK IN RED BRICK IN CEMENT MORTAR 1:6
 - 3) ALL COLUMN BEAM IN TOR STEEL # 1:2:4 CEMENT CONCRETE.
 - 4) FOOTING 1" I.P.S 1:2:4 OVER FLAT BRICK SOLING AND MOSAIC AS PER REQUIREMENT.
 - 5) R.C.C ROOF SLAB 4" THK. IN 1:2:4
 - 6) STAIR WAIST SLAB 4" THK. STEPS 250MMX150MM.
 - 7) CHHAJJA 3" THK. 0.54 WIDE IN R.C.C 1:2:4.
 - 8) PLASTER 1/2" THK. 1:8 INSIDE# 1:6 OUTSIDE CELLING 1/4" THK. IN 1:4
 - 9) WOOD WORK 1 1/2" THK. FLUSH DOOR WINDOW IN STEEL GLAZED AS PER DESIGN.

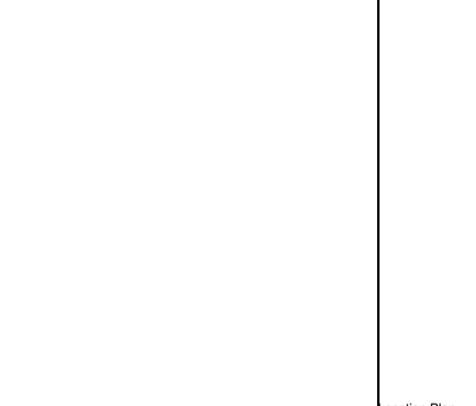
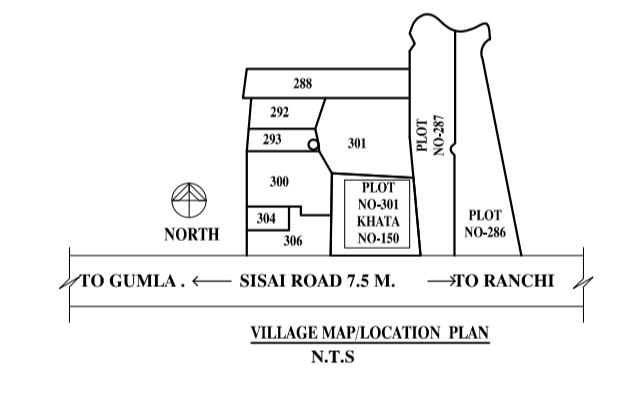

Elevation 1 Detail

DOOR WINDOW OPENING SCHEDULE :

S.NO	TYPE	SIZE	CELL LEVEL	LN. LEVEL	DESCRIPTION
1.	D1	1771	-	2550	DOUBLE SHUTTER GLAZED DOOR
2.	D1	1250	-	2550	DOUBLE SHUTTER GLAZED DOOR
3.	D2	1050	-	2550	SINGLE SHUTTER GLAZED DOOR
4.	D3	750	-	2550	SINGLE SHUTTER GLAZED DOOR
5.	W1	1200	1050	2550	5 LEAF GLAZED WINDOW
6.	V1	4771	1800	2100	VENTILATOR
7.	V2	3114	1800	2100	VENTILATOR
8.	V3	800	1800	2000	VENTILATOR

AREA STATEMENTS

S.NO	FLOOR	PROPOSED AREA (WITH STAIRS)	TOTAL FAR = 508.94
1	LOWER GROUND	105.22	
2	GROUND FLOOR	119.67	119.67
3	FIRST FLOOR	119.67	119.67
4	TYP.2nd TO 3rd FLOOR	269.6	269.6
5	MUMTY & MACHIN ROOM	34.07	
6	TOTAL	924.45	508.94

TOTAL PROPOSED AREA = 924.45 SQMT

AREA STATEMENT:-
 TOTAL PLOT AREA = 323.68 SQMT AS PER DEED
 TOTAL PLOT AREA = 324.16 SQMT. AS PER SITE
 PER.F.A.R.ALLOWED = 2.5 OF 324.16 = 810.4 SQMT
 PERM. COVD. AREA ON G.F @ 50% = 119.67 SQMT
 GROUND COVERAGE = 36.91%
 TOTAL BUILTUP AREA = 508.94 SQMT.

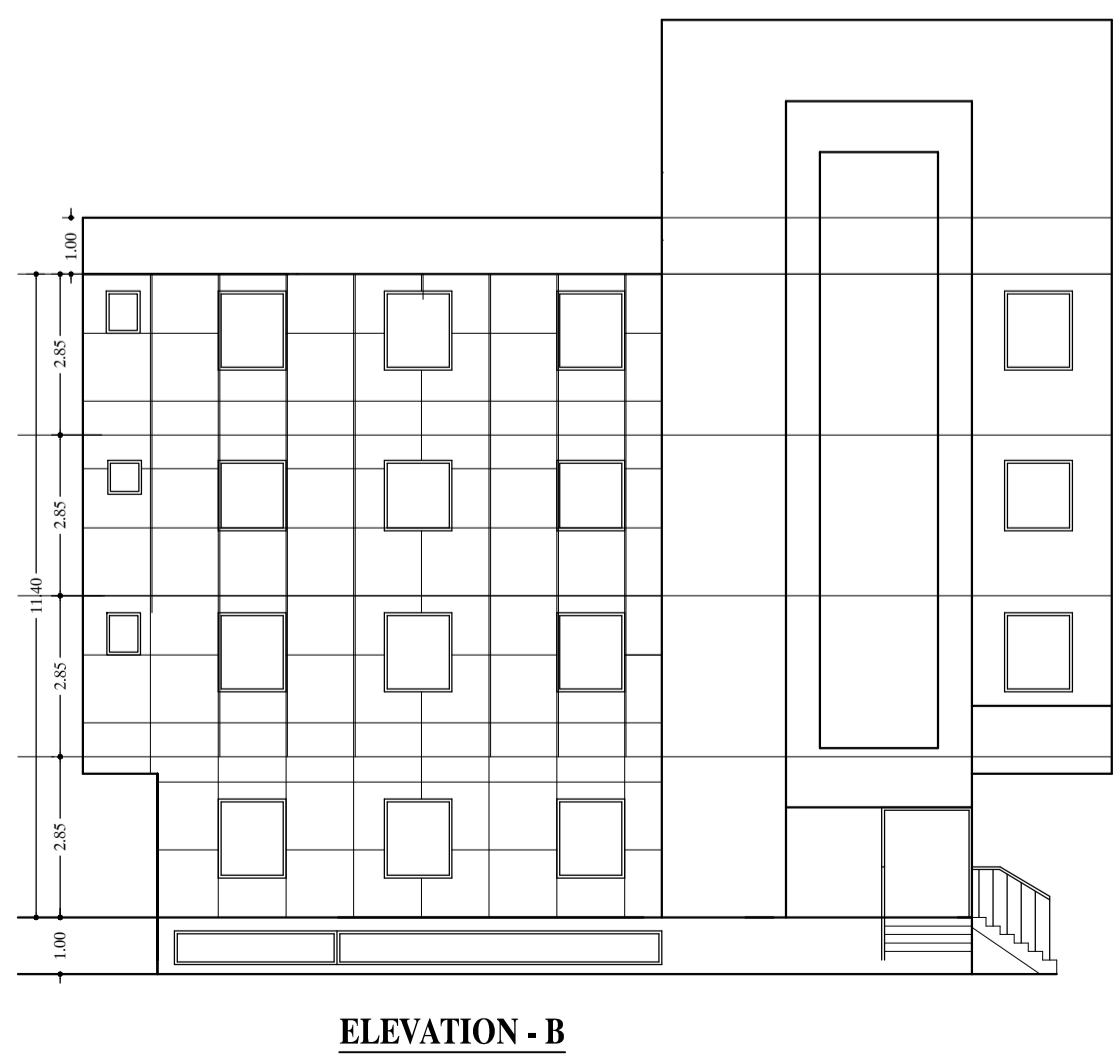

Elevation 2 Detail

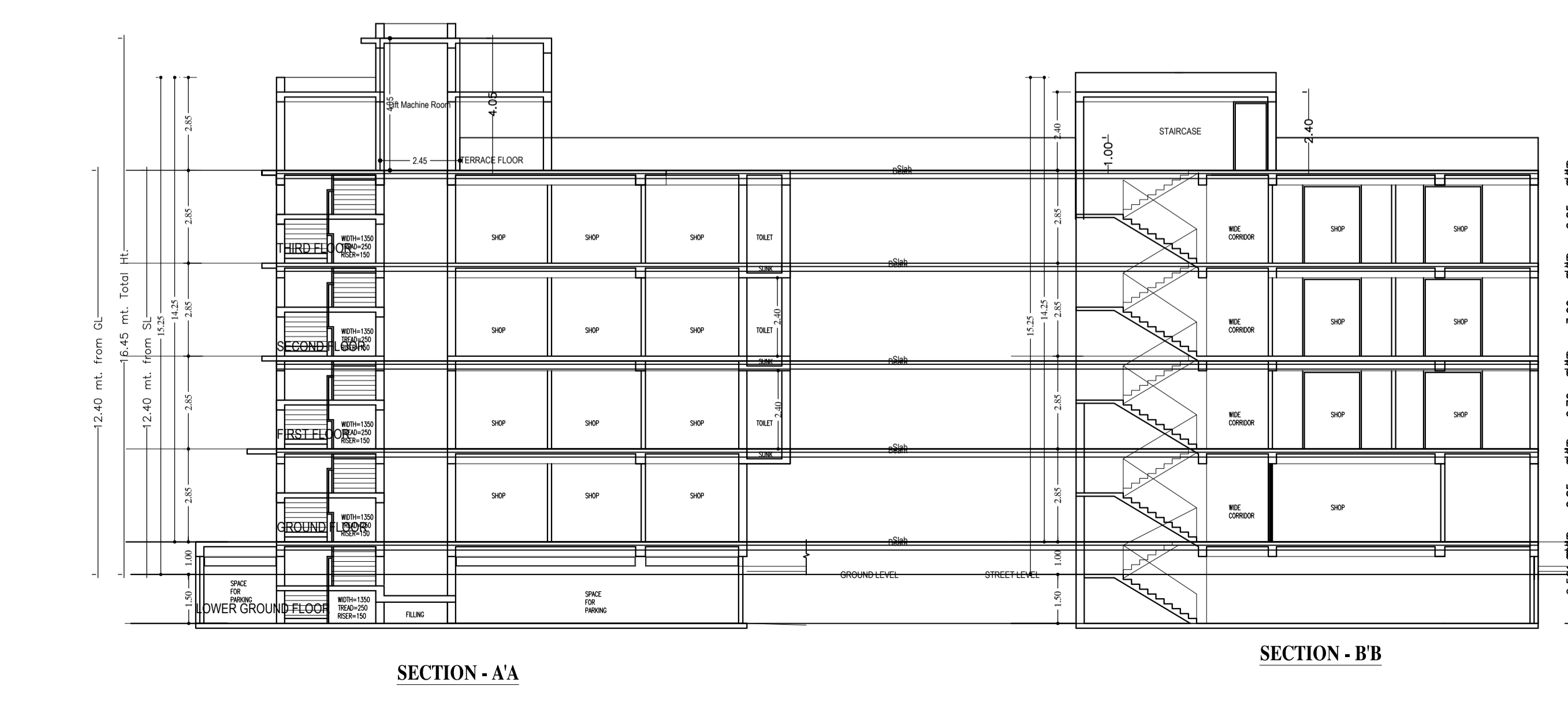

Owner Sign:-

Architect Sign:-

Project:-
 PROPOSED COMMERCIAL BUILDING PLAN OF SHRI.MANOJ KUMAR SINGH, S/O- SHRI RAJESHWAR PRASAD SINGH, AT VILLAGE-GUMLA,THANA NO-59,ON PART RS PLOT NO-302, KHATA NO - 150, THANA & DIST- GUMLA .

TITLE:- SANCTION DRAWING

Org. No SB-01

SCALE=1:100

Drawn -

Checked -