

SECTION -CC

10 TOR @150 C/C
BOTH WAY
R.C.C. JALI

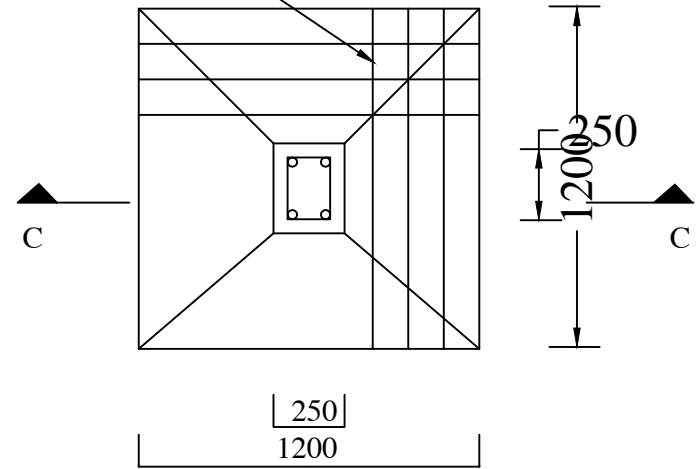

PLAN

DETAIL OF FOUNDATION