

SECTION X-X

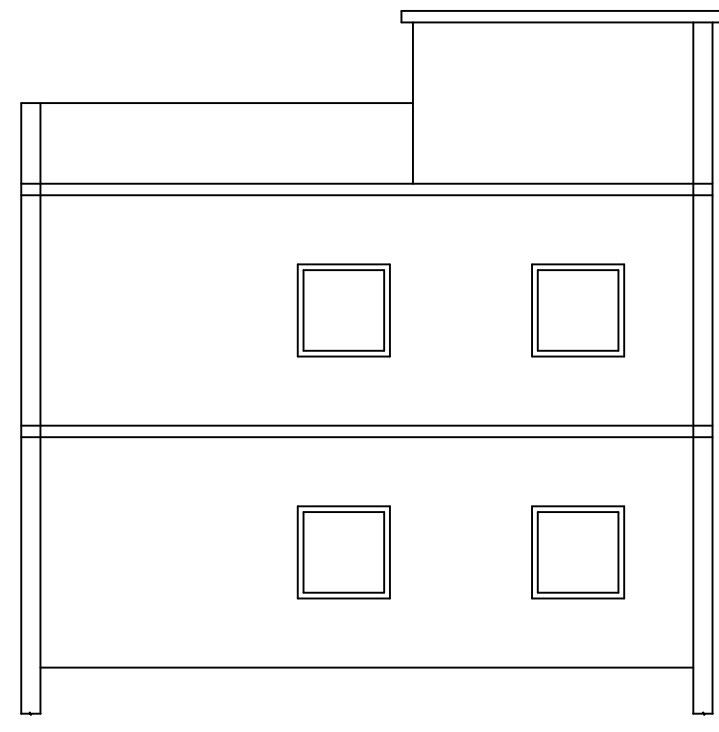

SECTION Y-Y

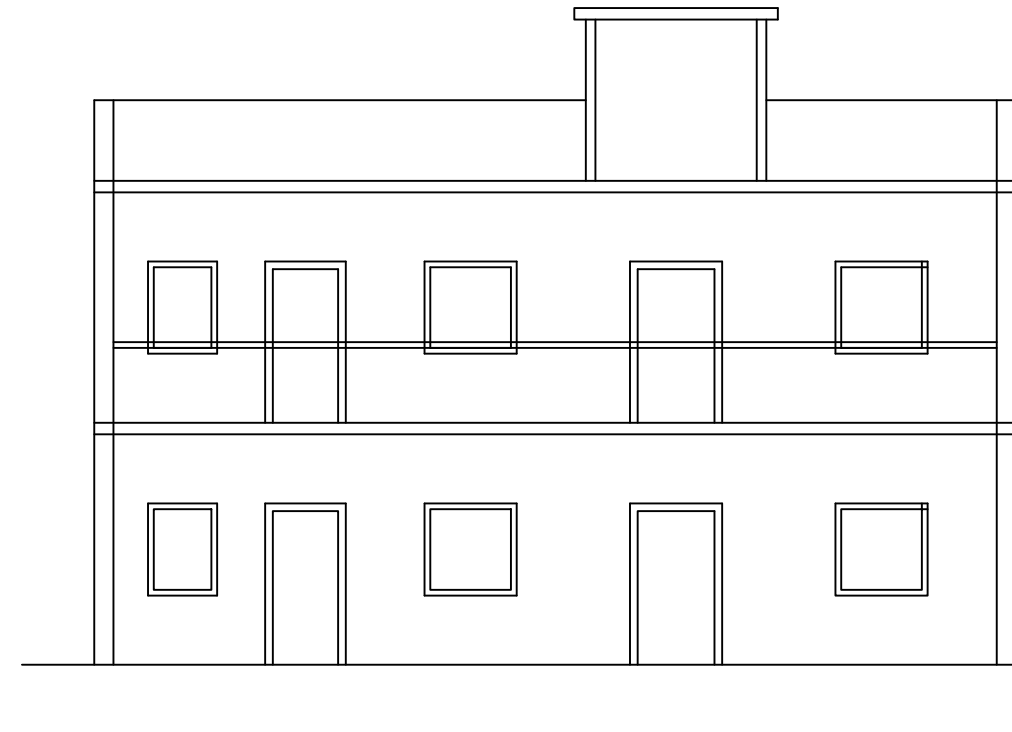

FRONT ELEVATION

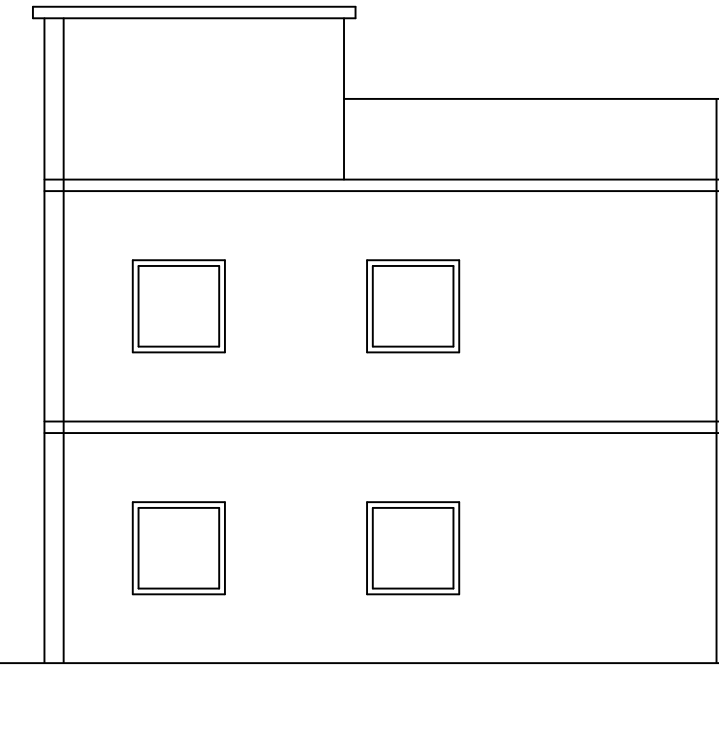

SIDE ELEVATION

SCHEDULE OF DOOR:

| BUILDING NAME              | NAME | LENGTH | HEIGHT | NOS |
|----------------------------|------|--------|--------|-----|
| SUSHILA TIGGA (A BUILDING) | D1   | 0.61   | 2.10   | 08  |
| SUSHILA TIGGA (A BUILDING) | D    | 0.91   | 2.10   | 10  |
| SUSHILA TIGGA (A BUILDING) | D4   | 1.07   | 2.10   | 03  |
| SUSHILA TIGGA (A BUILDING) | D3   | 1.22   | 2.10   | 01  |

SCHEDULE OF WINDOW/VENTILATION:

| BUILDING NAME              | NAME | LENGTH | HEIGHT | NOS |
|----------------------------|------|--------|--------|-----|
| SUSHILA TIGGA (A BUILDING) | V    | 0.60   | 1.20   | 02  |
| SUSHILA TIGGA (A BUILDING) | V    | 0.61   | 1.20   | 04  |
| SUSHILA TIGGA (A BUILDING) | W1   | 0.91   | 1.20   | 02  |
| SUSHILA TIGGA (A BUILDING) | W2   | 0.91   | 1.20   | 02  |
| SUSHILA TIGGA (A BUILDING) | W    | 1.22   | 1.20   | 12  |

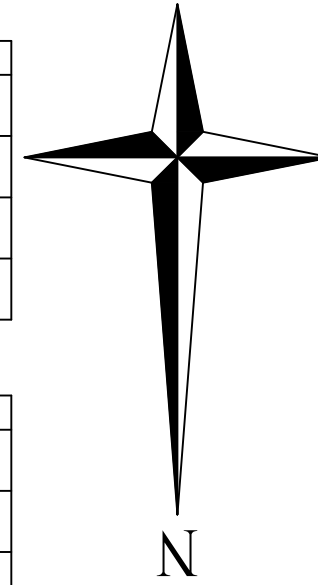

Proposal Basic Information

|                   |                                    |
|-------------------|------------------------------------|
| Proposal File No. | GUNPC/BP/0048/W11/2022             |
| Owner Name        | SUSHILA TIGGA                      |
| Khata No          | 41                                 |
| Plot No           | 1509                               |
| Village Name      | Shanti Nagar                       |
| Use               | Residential                        |
| SubUse            | Bungalow/ Dwelling / Non Apartment |

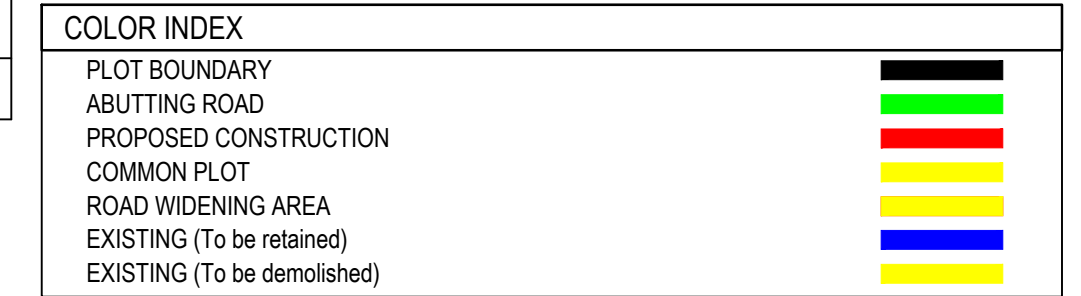

Building USE/SUBUSE Details

| Building Name              | Building Use | Building SubUse                    | Building Structure |
|----------------------------|--------------|------------------------------------|--------------------|
| SUSHILA TIGGA (A BUILDING) | Residential  | Bungalow/ Dwelling / Non Apartment | Non-Highrise       |

FAR & Tenement Details (Table 4c-1)

| Building                   | No. of Same Bldg | Total Built Up Area (Sq.mt.) | Proposed FAR Area (Sq.mt.) Resi. | Total FAR Area (Sq.mt.) | Total Consumed Additional FAR Area (Sq.mt.) | Trmt (No.) |
|----------------------------|------------------|------------------------------|----------------------------------|-------------------------|---|------------|
| SUSHILA TIGGA (A BUILDING) | 1                | 222.96                       | 222.96                           | 222.96                  | 222.96                                      | 01         |
| Grand Total                | 1                | 222.96                       | 222.96                           | 222.96                  | 222.96                                      | 01         |

Buildingwise Floor FAR Details

| Floor Name    | Building Name                   |                            | Total                                 |                         |
|---------------|---------------------------------|----------------------------|---------------------------------------|-------------------------|
|               | Proposed Built Up Area (Sq.mt.) | Proposed FAR Area (Sq.mt.) | Total Proposed Built Up Area (Sq.mt.) | Total FAR Area (Sq.mt.) |
| Ground Floor  | 111.48                          | 111.48                     | 111.48                                | 111.48                  |
| First Floor   | 111.48                          | 111.48                     | 111.48                                | 111.48                  |
| Terrace Floor | 0.00                            | 0.00                       | 0.00                                  | 0.00                    |
| Total :       | 222.96                          | 222.96                     | 222.96                                | 222.96                  |

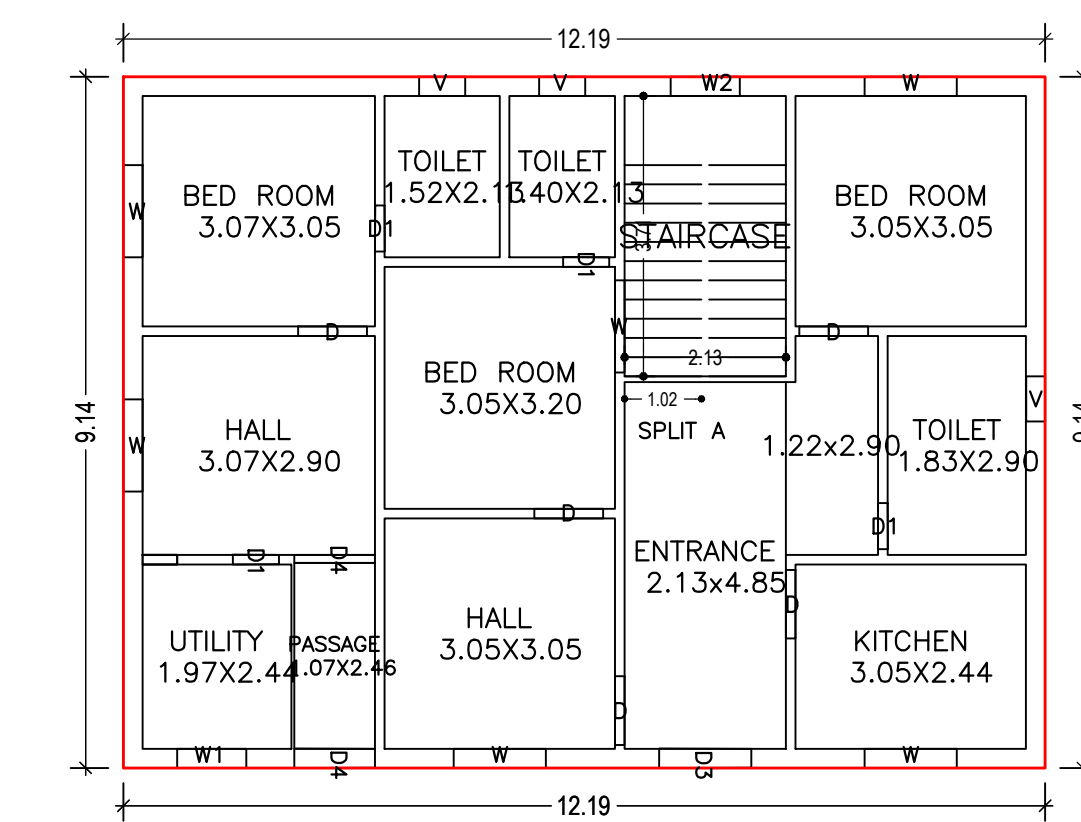

GROUND FLOOR PLAN (Proposed) (SCALE 1:100)

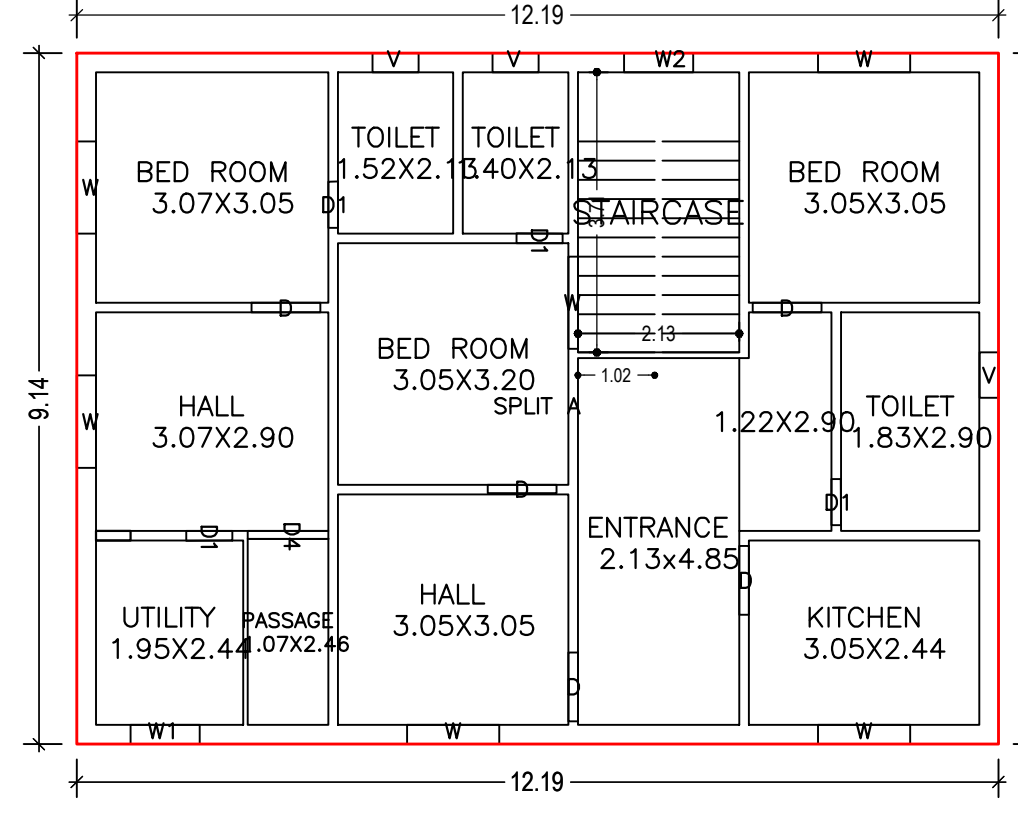

FIRST FLOOR PLAN (Proposed) (SCALE 1:100)

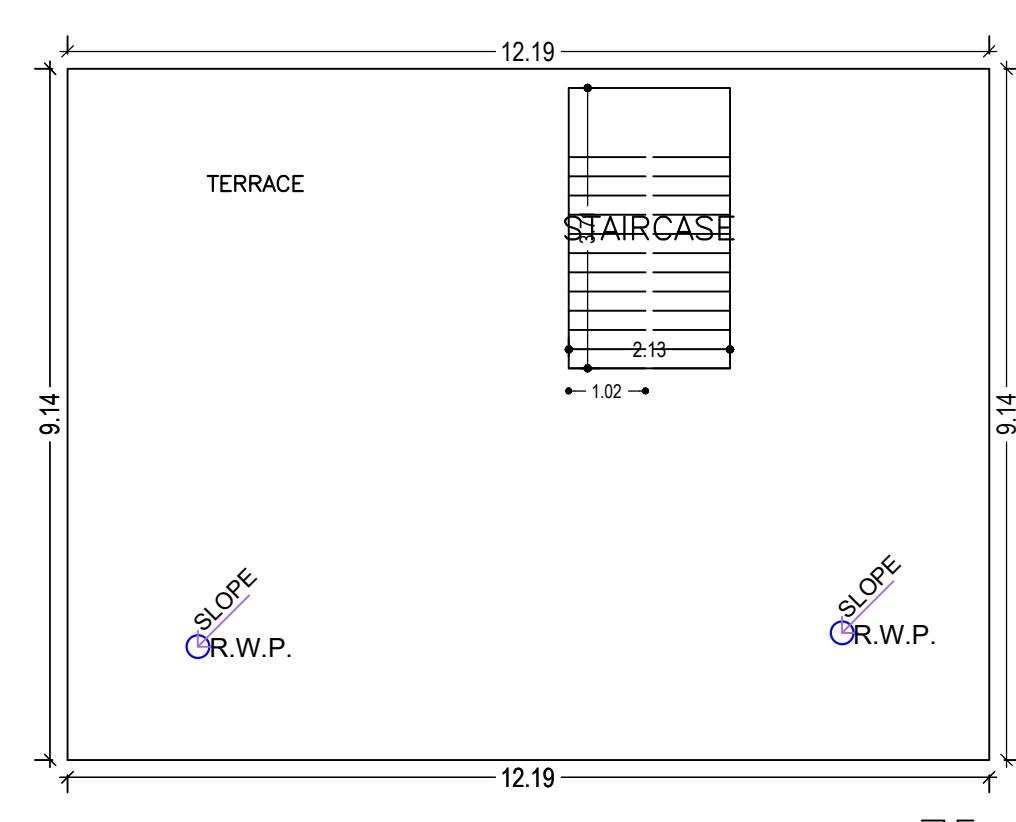

TERRACE FLOOR PLAN (SCALE 1:100)

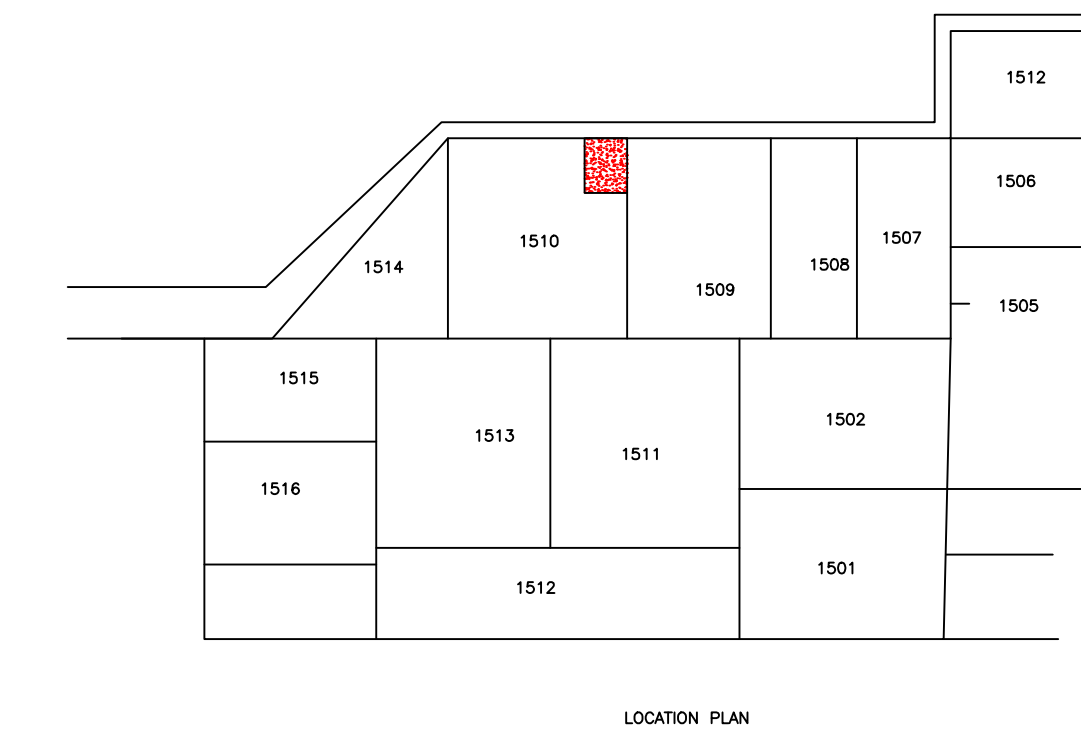

LOCATION PLAN

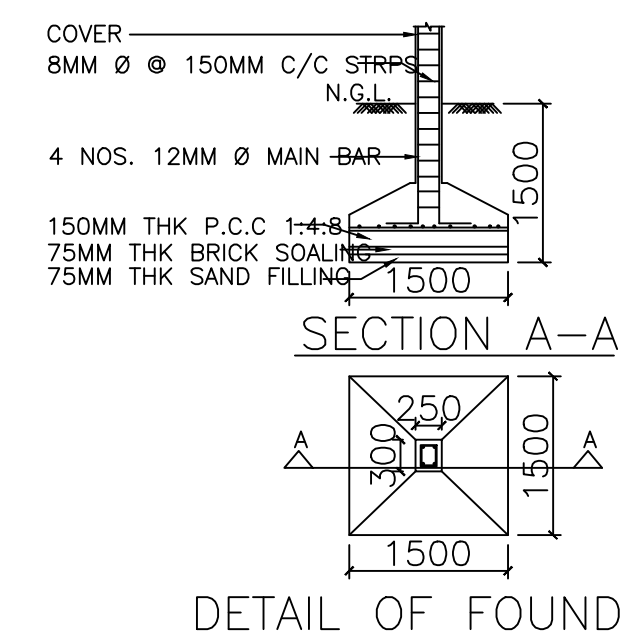

DETAIL OF FOUNDATION

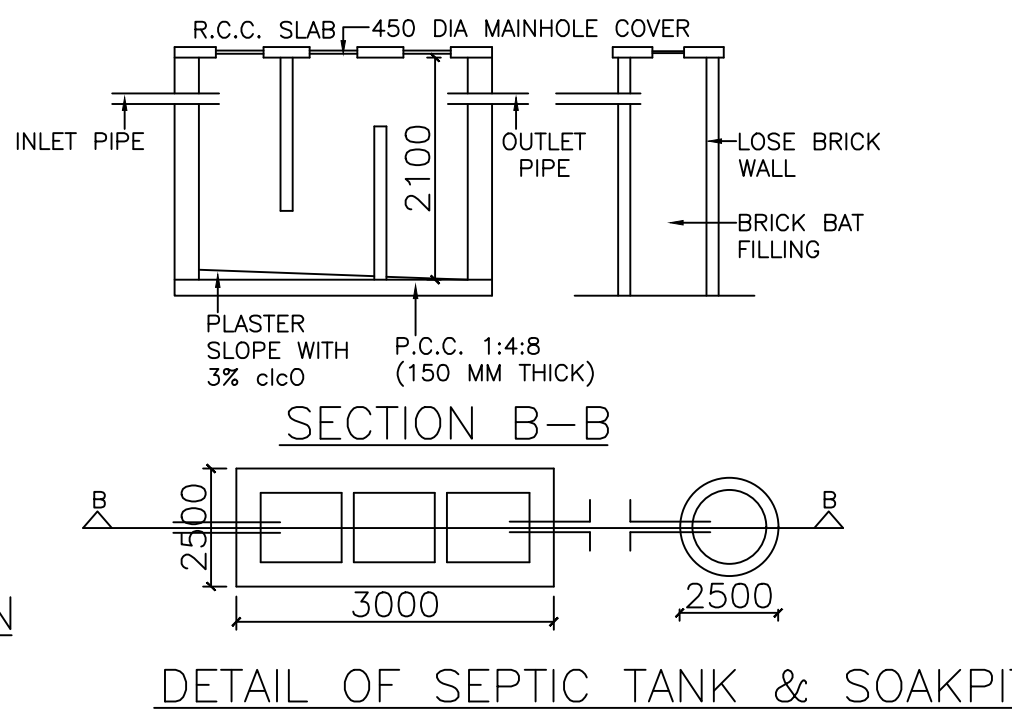

DETAIL OF SEPTIC TANK & SOAKPIT

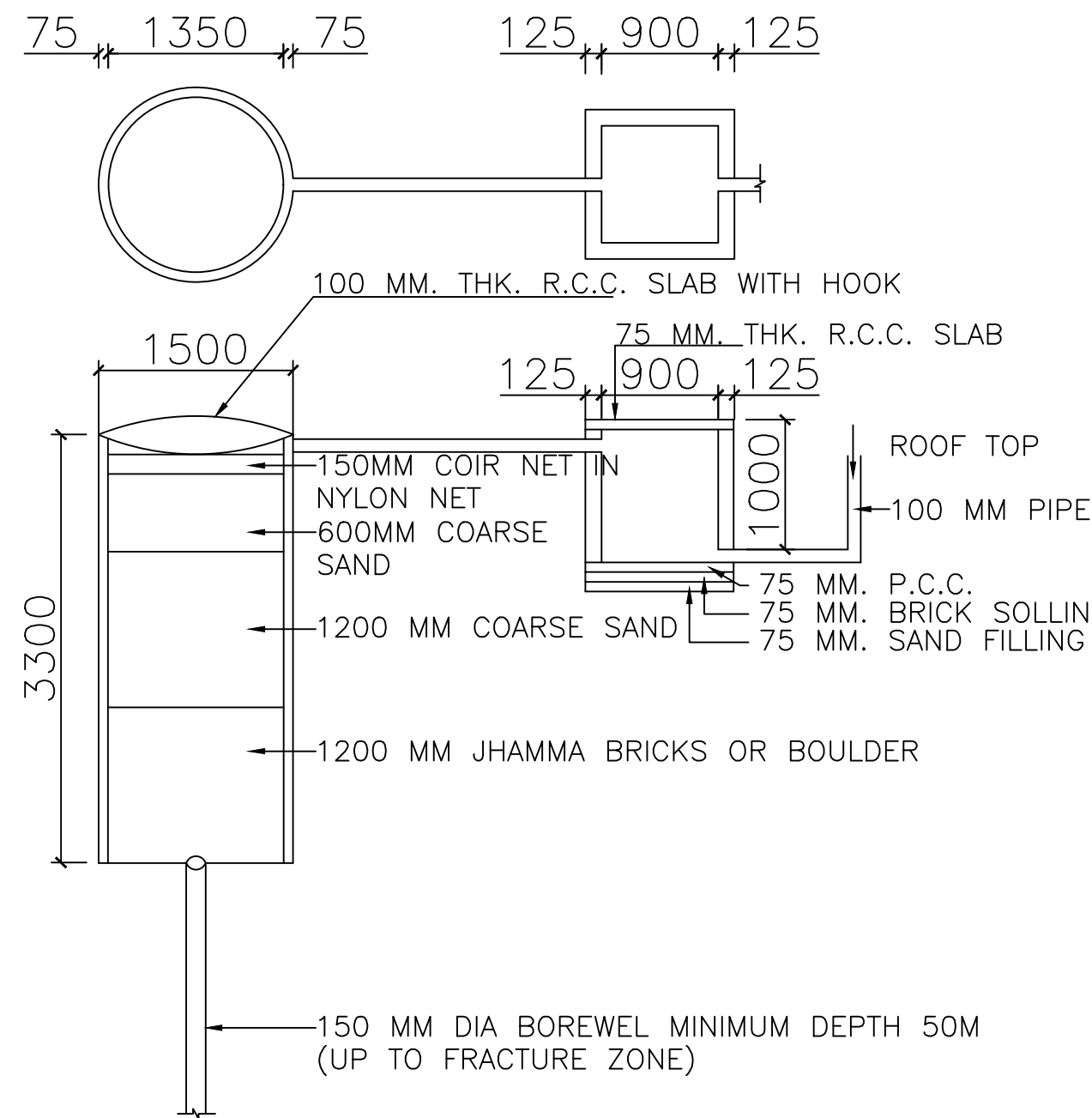

DETAIL OF GROUND WATER RECHARGE PIT WITH SILT TANK

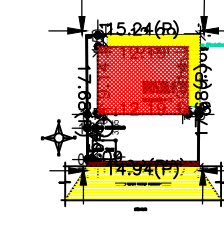

Building :SUSHILA TIGGA (A BUILDING)

| Floor Name    | Total Built Up Area (Sq.mt.) | Proposed FAR Area (Sq.mt.) | Total FAR Area (Sq.mt.) | Total Consumed Additional FAR Area (Sq.mt.) | Trmt (No.) |
|---------------|------------------------------|----------------------------|-------------------------|---|------------|
| Ground Floor  | 111.48                       | 111.48                     | 111.48                  | 111.48                                      | 01         |
| First Floor   | 111.48                       | 111.48                     | 111.48                  | 111.48                                      | 01         |
| Terrace Floor | 0.00                         | 0.00                       | 0.00                    | 0.00  | 00         |
| Total         | 222.96                       | 222.96                     | 222.96                  | 222.96                                      | 01         |

UnitBUA Table for Building :SUSHILA TIGGA (A BUILDING)

| FLOOR             | Name    | UnitBUA Type | UnitBUA Area | Carpet Area | No. of Rooms | No. of Tenement |
|-------------------|---------|--------------|--------------|-------------|--------------|-----------------|
| GROUND FLOOR PLAN | SPLIT A | FLAT         | 183.74       | 183.83      | 12           | 1               |
|                   | SPLIT A | FLAT         | 0.00         | 0.00        | 12           | 0               |
| FIRST FLOOR PLAN  | SPLIT A | FLAT         | 183.74       | 183.83      | 12           | 1               |
|                   | SPLIT A | FLAT         | 0.00         | 0.00        | 12           | 0               |

Structure Detail

Septic Tank Detail

Rain Water Storage Tank Detail

Structure Detail