

Proposal Basic Information

Proposal File No.	GUNPC/BP/0030/W20/2022
Owner Name	KAMLESH KUMAR JHA AND AMRESH KUMAR JHA
Khata No	14,14
Plot No	1475,963
Village Name	Sarna Toli
Use	Residential
SubUse	Bungalow/ Dwelling / Non Apartment

Buildingwise Floor FAR Details

Floor Name	Building Name				Total			
	Proposed Built Up Area (Sq.mt.)	Existing Built Up Area (Sq.mt.)	Proposed FAR Area (Sq.mt.)	Existing FAR Area (Sq.mt.)	Total Proposed Built Up Area (Sq.mt.)	Total Existing Built Up Area (Sq.mt.)	Total FAR Area (Sq.mt.)	Total Existing FAR Area (Sq.mt.)
Ground Floor	0.00	152.27	0.00	152.27	0.00	152.27	0.00	152.27
First Floor	0.00	152.27	0.00	152.27	0.00	152.27	0.00	152.27
Second Floor	151.34	0.00	151.34	0.00	151.34	0.00	151.34	0.00
Terrace Floor	0.00	0.00	0.00	0.00	0.00	0.00	0.00	0.00
Total:	151.34	304.54	151.34	304.54	151.34	304.54	151.34	304.54

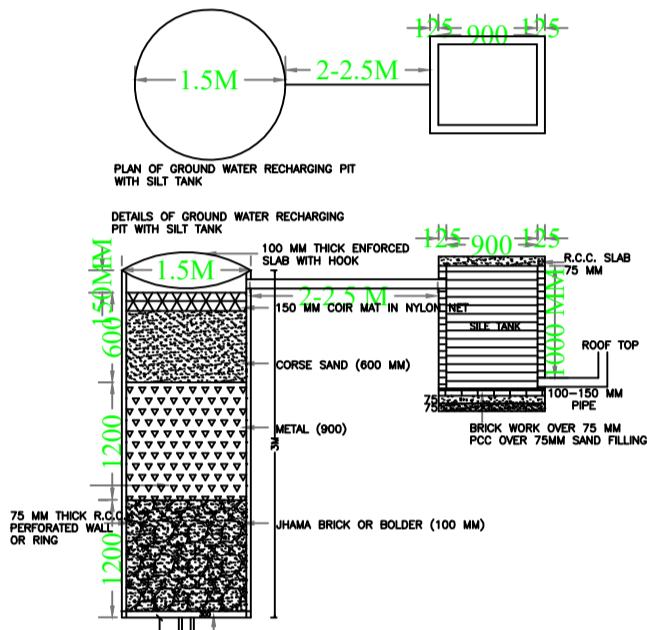
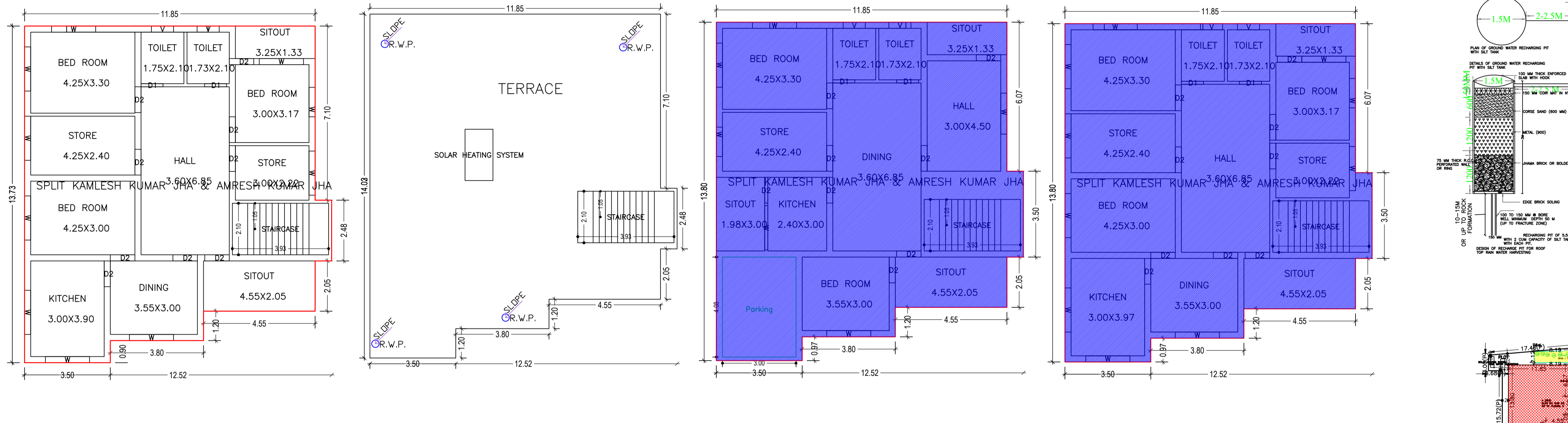

SCHEDULE OF DOOR:

A (RES)	NAME	LENGTH	HEIGHT	NOS
A (RES)	D1	0.90	2.10	06
A (RES)	D2	1.00	2.10	10
A (RES)	D3	1.05	2.10	16

SCHEDULE OF WINDOW/VENTILATION:

A (RES)	NAME	LENGTH	HEIGHT	NOS
A (RES)	V	0.90	1.20	06
A (RES)	W	1.20	1.20	03
A (RES)	W	1.68	1.20	01
A (RES)	W	1.80	1.20	22

UnitBUA Table for Building -A (RES)

FLOOR	Name	UnitBUA Type	Entity Type	UnitBUA Area	Carpet Area	No. of Rooms	No. of Tenement
SECOND FLOOR PLAN	SPLIT KAMLESH KUMAR JHA & AMRESH KUMAR JHA	FLAT	Proposed	0.00	0.00	12	0
FIRST FLOOR PLAN	SPLIT KAMLESH KUMAR JHA & AMRESH KUMAR JHA	FLAT	Existing	0.00	0.00	12	0
GROUND FLOOR PLAN	SPLIT KAMLESH KUMAR JHA & AMRESH KUMAR JHA	FLAT	Existing	455.88	452.05	11	1
Total:				455.88	452.05	35	1

Building -A (RES)

Floor Name	Total Built Up Area (Sq.mt.)	Existing Built Up Area (Sq.mt.)	Proposed Built Up Area (Sq.mt.)	Existing FAR Area (Sq.mt.)	Proposed FAR Area (Sq.mt.)	Total FAR Area (Sq.mt.)	Total Consumed Additional FAR Area (Sq.mt.)	Trmt (No.)
Ground Floor	152.27	152.27	0.00	152.27	0.00	152.27	152.27	01
First Floor	152.27	0.00	152.27	0.00	152.27	152.27	152.27	00
Second Floor	151.34	0.00	151.34	0.00	151.34	151.34	151.34	00
Terrace Floor	0.00	0.00	0.00	0.00	0.00	0.00	0.00	00
Total:	455.88	304.54	151.34	304.54	151.34	455.88	455.88	01

AREA STATEMENT GUMLA NAGAR (PARISHAD) VERSION NO: 1.0.82

PROJECT DETAIL: REGION: JHARKHAND URBAN LOCAL BODIES: District: GUMLA Authority: GUMLA NAGAR PARISHAD

PROJECT TYPE: Building Permission

AREA DETAILS: AREA OF PLOT (Minimum): 263.08; NET AREA OF PLOT (Gross Plot Area): 263.08; Deduction from Gross Plot Area: 0.00; Deduction for Balance Plot Area from Gross Plot Area: 0.00; Common Plot Area: 17.95; BALANCE AREA OF PLOT (Net Plot Area - Recreational/Amenity space): 245.13; PLOT AREA FOR COVERAGE (Net Plot Area): 263.08; Plot Area for FAR (Net Plot Area + Road/Widening Area): 263.08

COVERAGE CHECK: Permissible Coverage area (90.00 %): 152.27; Proposed Coverage Area (57.88 %): 152.27; Total Prop. Coverage Area (57.88 %): 152.27; Balance coverage area (2.12 %): 5.58

FAR CHECK: Perm. FAR Area (2.00): 526.16; Total Perm. FAR area: 526.16; Proposed FAR Area: 455.88; Total Proposed FAR Area: 455.88; Consumed FAR (Factor): 1.73; Balance FAR Area: 70.28

BUILT UP AREA CHECK: Total Proposed BuiltUp Area: 455.88

ARCHITECT (Regd): DEEPAK DIWAN
ENGINEER (Regd):
SUPERVISOR (Regd): KAMLESH KUMAR JHA AND AMRESH KUMAR JHA
OWNER (Regd):
DEVELOPMENT AUTHORITY: LOCAL BODY

FAR & Tenement Details (Table 4c-1)

Building	No. of Same Bldg	Total Built Up Area (Sq.mt.)	Existing Built Up Area (Sq.mt.)	Proposed Built Up Area (Sq.mt.)	Existing FAR Area (Sq.mt.)	Proposed FAR Area (Sq.mt.)	Total FAR Area (Sq.mt.)	Total Consumed Additional FAR Area (Sq.mt.)	Trmt (No.)
A (RES)	1	455.88	304.54	151.34	304.54	151.34	455.88	455.88	01
Grand Total	1	455.88	304.54	151.34	304.54	151.34	455.88	455.88	01

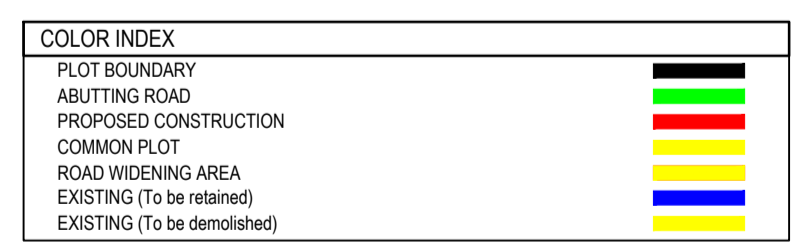

Building USE/SUBUSE Details

Building Name	Building Use	Building SubUse	Building Structure
A (RES)	Residential	Bungalow/ Dwelling / Non Apartment	Non-Highrise

LTP NAME AND SIGNATURE	STRUCTURAL ENG'S NAME AND SIGNATURE	BUILDER NAME AND SIGNATURE	DIGITAL SIGNATURE
DEEPAK DIWAN GUNPC/ARC/0003/2017			