

Proposal Basic Information

Proposal File No.	GUNPC/BP/0024/W04/2022
Owner Name	ONILA KUJUR
Khata No	42
Plot No	308
Village Name	Chetar
Use	Residential
SubUse	Bungalow/ Dwelling / Non Apartment

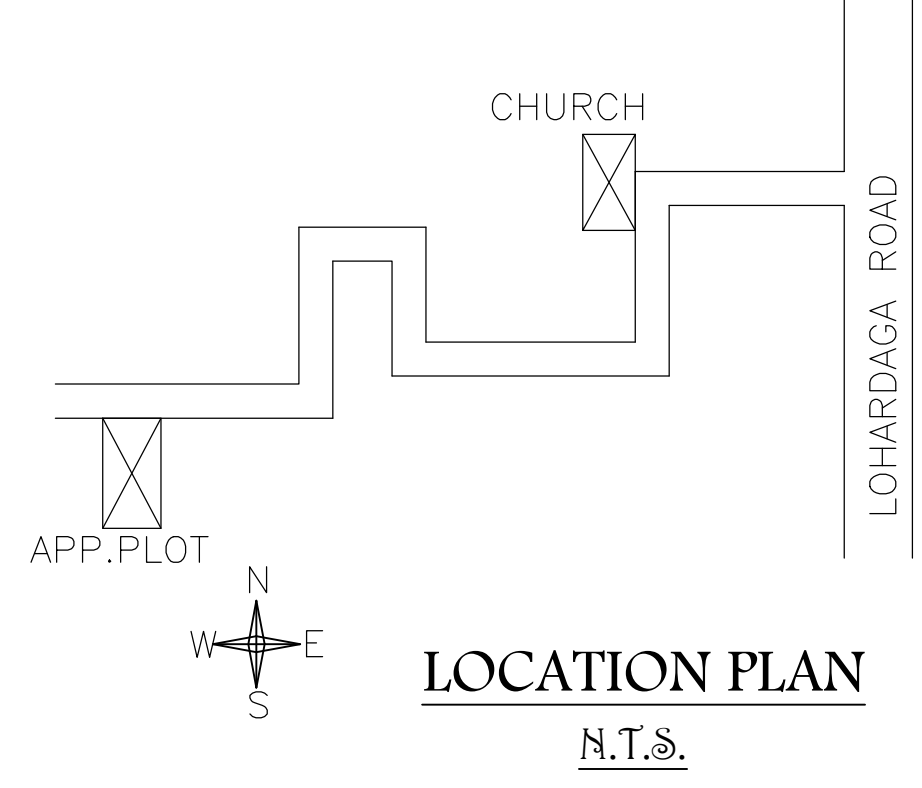
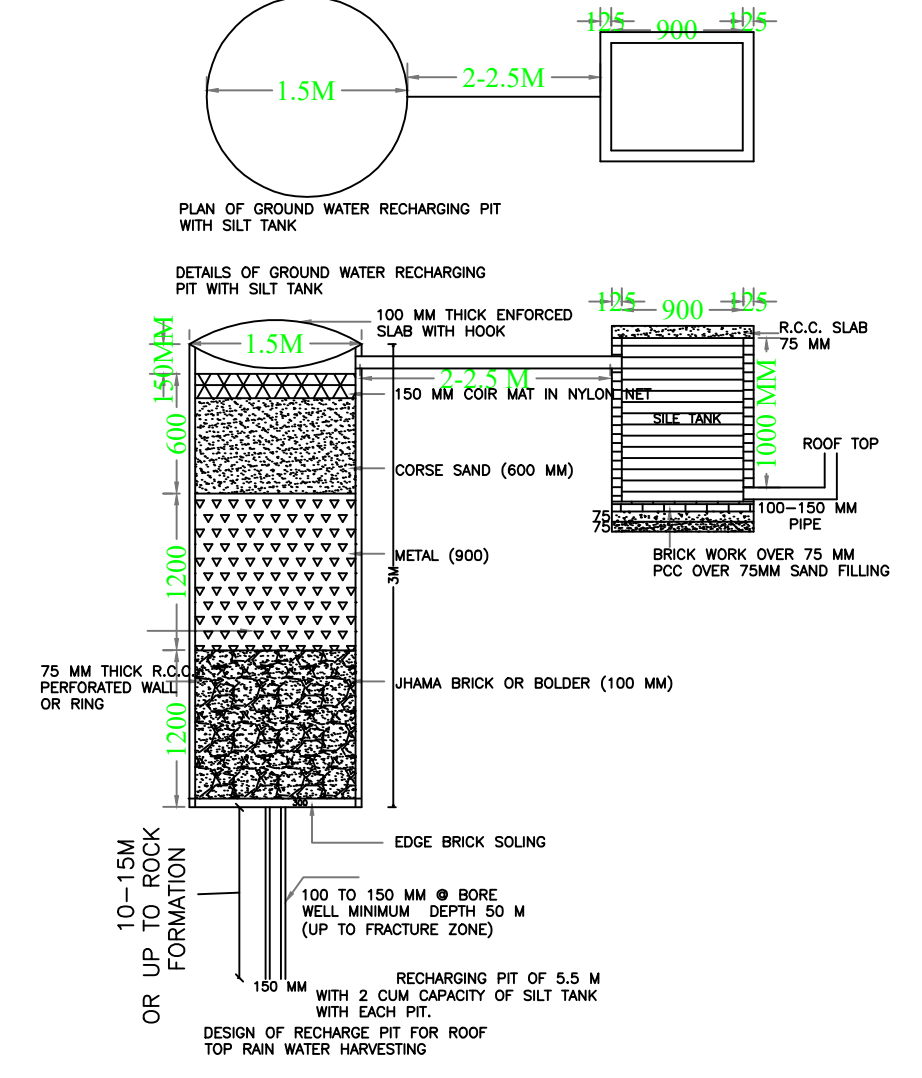
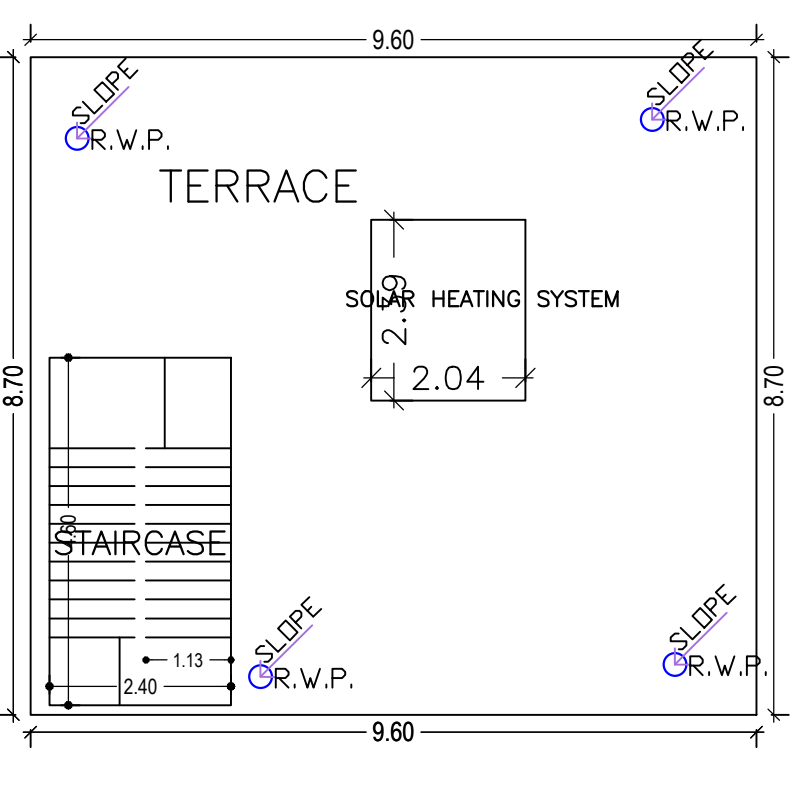
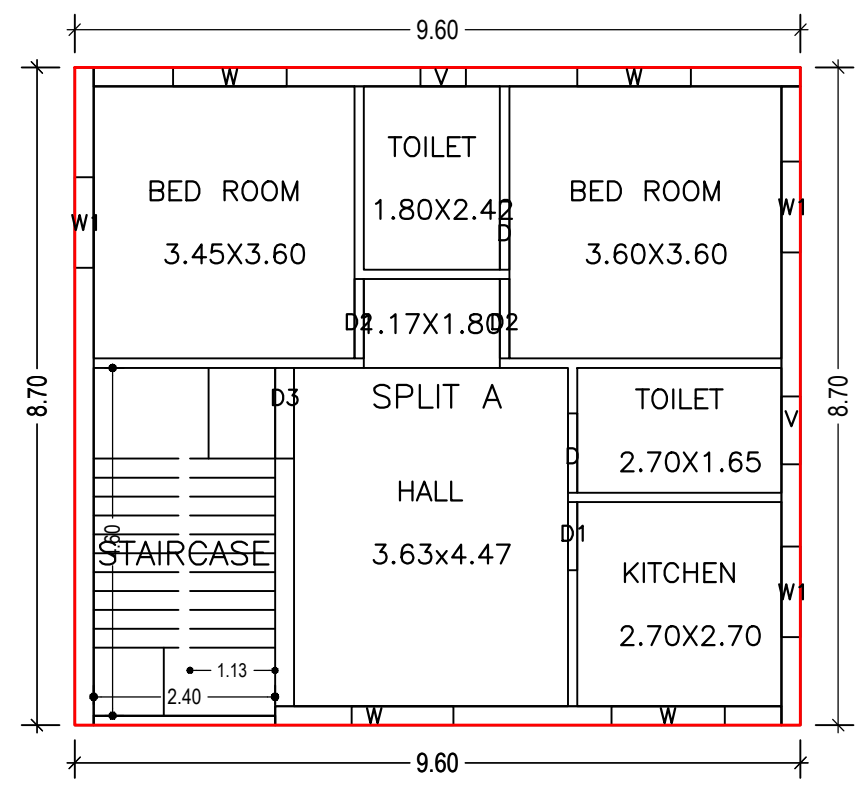
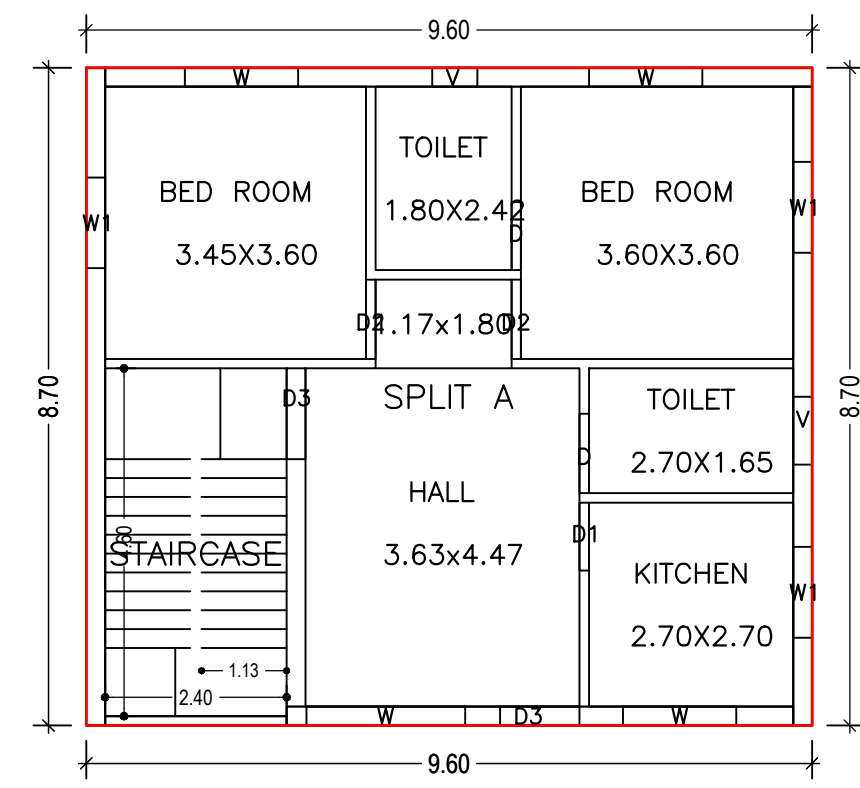
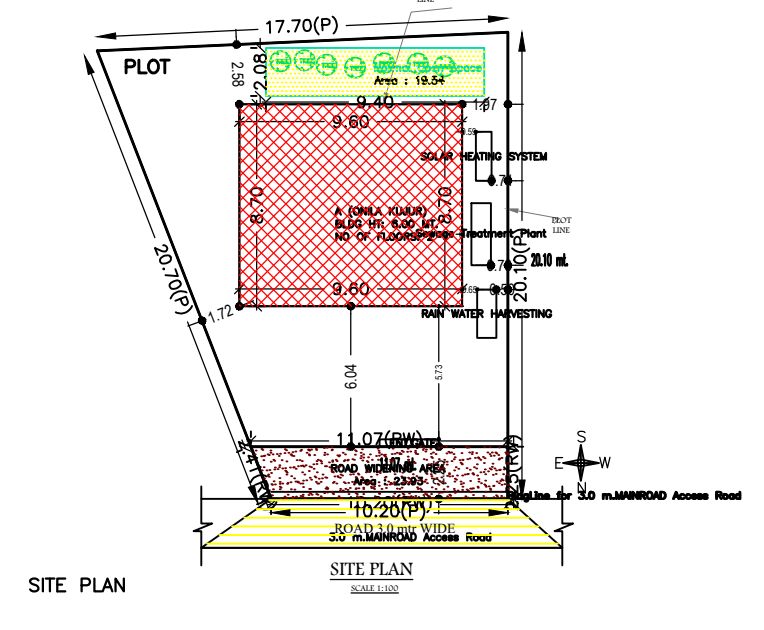
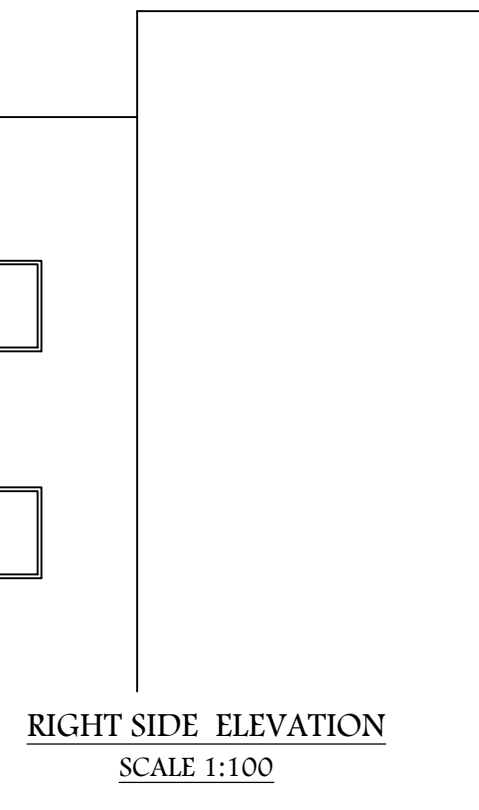
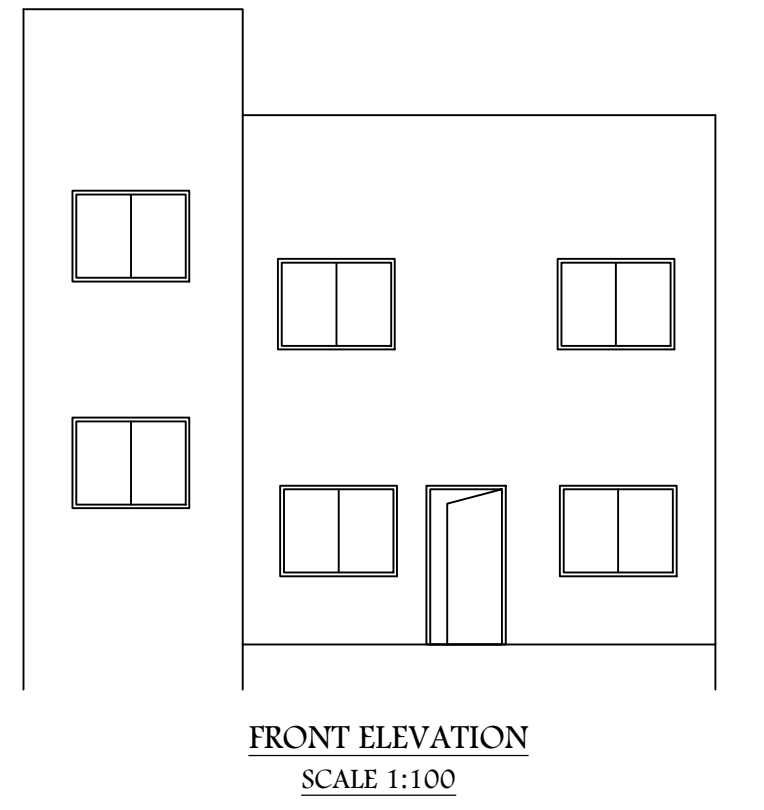
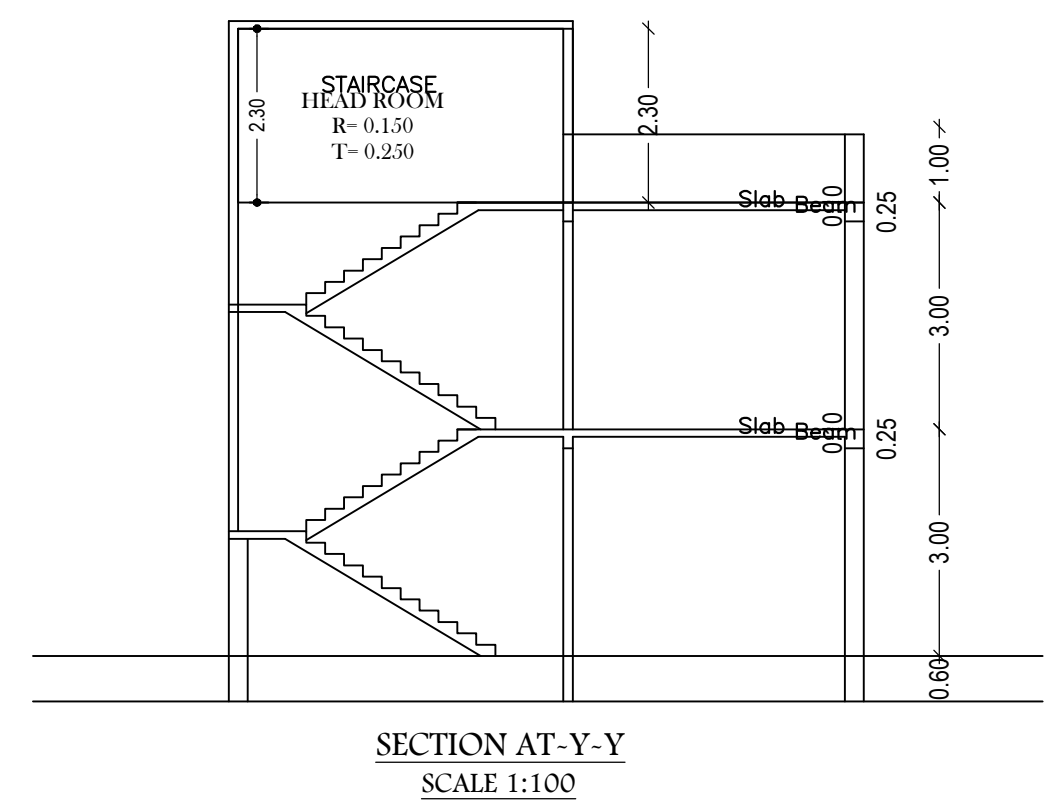
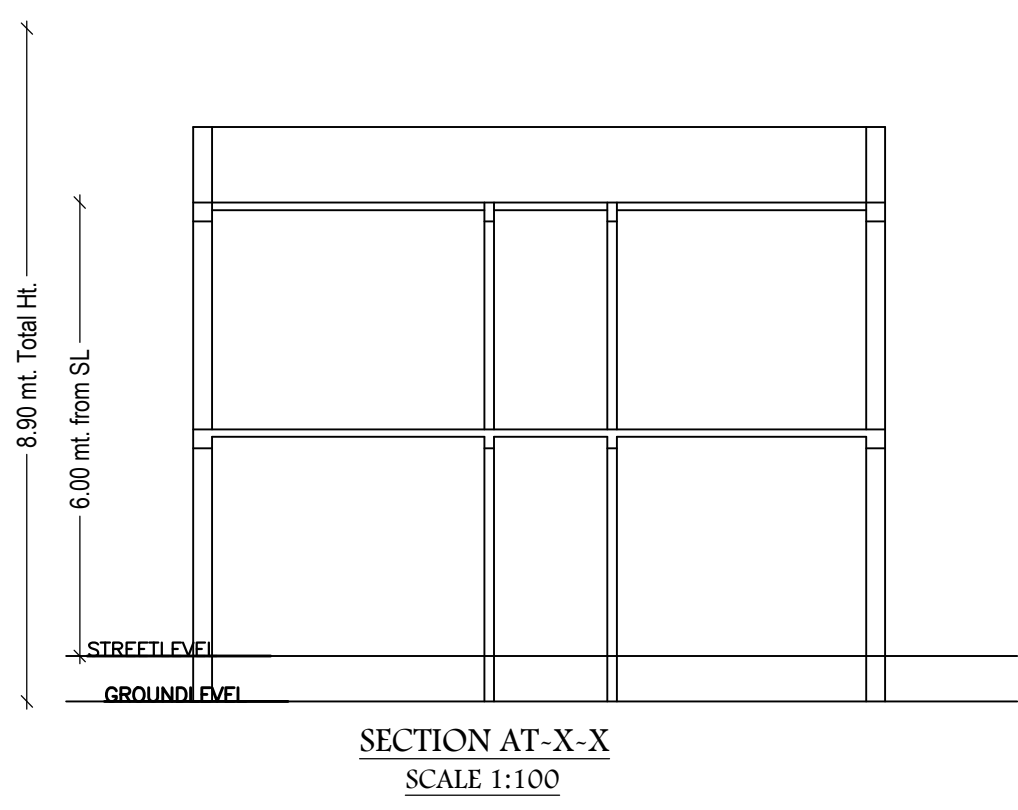

Buildingwise Floor FAR Details

Floor Name	Building Name A (ONILA KUJUR)		Total	
	Proposed Built Up Area (Sq.mt.)	Proposed FAR Area (Sq.mt.)	Total Proposed Built Up Area (Sq.mt.)	Total FAR Area (Sq.mt.)
Ground Floor	83.52	83.52	83.52	83.52
First Floor	83.52	83.52	83.52	83.52
Terrace Floor	0.00	0.00	0.00	0.00
Total :	167.04	167.04	167.04	167.04

SCHEDULE OF DOOR:

BUILDING NAME	NAME	LENGTH	HEIGHT	NOS
A (ONILA KUJUR)	D	0.90	2.10	02
A (ONILA KUJUR)	D1	0.90	2.10	02
A (ONILA KUJUR)	D2	1.05	2.10	04
A (ONILA KUJUR)	D	1.05	2.10	02
A (ONILA KUJUR)	D3	1.05	2.10	01
A (ONILA KUJUR)	D3	1.20	2.10	02

SCHEDULE OF WINDOW/VENTILATION:

BUILDING NAME	NAME	LENGTH	HEIGHT	NOS
A (ONILA KUJUR)	V	0.60	1.20	02
A (ONILA KUJUR)	V	0.90	1.20	02
A (ONILA KUJUR)	W1	1.20	1.20	06
A (ONILA KUJUR)	W	1.35	1.20	01
A (ONILA KUJUR)	W	1.50	1.20	06
A (ONILA KUJUR)	W	2.10	1.20	01

GROUND FLOOR PLAN (Proposed) (SCALE 1:100)

FIRST FLOOR PLAN (Proposed) (SCALE 1:100)

TERRACE FLOOR PLAN (SCALE 1:100)

FAR & Tenement Details (Table 4c-1)

Building	No. of Same Bldg	Total Built Up Area (Sq.mt.)	Proposed FAR Area (Sq.mt.)	Total FAR Area (Sq.mt.)	Total Consumed Additional FAR Area (Sq.mt.)	Tnmt (No.)
A (ONILA KUJUR)	1	167.04	167.04	167.04	167.04	01
Grand Total :	1	167.04	167.04	167.04	167.04	01

AREA STATEMENT GUMLA NAGAR PARISHAD		VERSION NO. : 1.0.62
PROJECT DETAIL:		VERSION DATE: 16/10/2020
Region: JHARKHAND URBAN LOCAL BODIES	Plot Use: Residential	
District: GUMLA	Plot SubUse: Bungalow/ Dwelling / Non Apartment	
Authority: GUMLA NAGAR PARISHAD	PlotNearby/ReligiousStructure: NA	
Inward No: GUNPC/BP/0024/W04/2022	Plot/SubPlot No: 308	
Application Type: General Proposal	North: -	
Project Type: Building Permission	South: -	
Nature of Development: New	East: -	
Location of Development Area: Old Area	West: -	
AREA DETAILS:		SQ.MT.
AREA OF PLOT (Minimum)	(A)	276.14
Deduction for NetPlot Area		
Road Widening Area		23.93
Total		23.93
NET AREA OF PLOT (Gross Plot Area - Deduction from Gross Plot area)	(A-Deductions)	252.20
Deduction for Balance Plot Area (from Gross Plot Area)		
Road Widening Area		23.93
Common Plot		19.94
Total		43.47
BALANCE AREA OF PLOT (Net Plot Area - Recreational/Amenity space)	(A-Deductions)	232.66
PLOT AREA FOR COVERAGE (Net Plot Area)	(A-Deductions)	252.20
Plot Area for FAR (Net Plot Area + RoadWidening Area)	(A-Deductions)	252.20
COVERAGE CHECK		
Permissible Coverage area (60.00 %)		151.32
Proposed Coverage Area (33.12 %)		83.52
Total Prop. Coverage Area (33.12 %)		83.52
Balance coverage area (26.88 %)		67.80
FAR CHECK		
Perm. FAR Area (1.20)		302.64
Total Perm. FAR area		302.64
Residential FAR		167.04
Proposed FAR Area		167.04
Total Proposed FAR Area		167.04
Consumed FAR (Factor)		0.66
Balance FAR Area		135.60
BUILT UP AREA CHECK		
Total Proposed BuiltUp Area		167.04
ARCHITECT (Regd)	DEEPAK DIWAN	
ENGINEER (Regd)		
SUPERVISOR (Regd)		
OWNER (Regd)	ONILA KUJUR	
DEVELOPMENT AUTHORITY		LOCAL BODY

Building :A (ONILA KUJUR)

Floor Name	Total Built Up Area (Sq.mt.)	Proposed FAR Area (Sq.mt.)	Total FAR Area (Sq.mt.)	Total Consumed Additional FAR Area (Sq.mt.)	Tnmt (No.)
Ground Floor	83.52	83.52	83.52	83.52	01
First Floor	83.52	83.52	83.52	83.52	00
Terrace Floor	0.00	0.00	0.00	0.00	00
Total :	167.04	167.04	167.04	167.04	01
Total Number of Same Buildings :	1				
Total :	167.04	167.04	167.04	167.04	01

UnitBUA Table for Building :A (ONILA KUJUR)

FLOOR	Name	UnitBUA Type	UnitBUA Area	Carpet Area	No. of Rooms	No. of Tenement
GROUND FLOOR PLAN	SPLIT A	FLAT	167.04	149.84	6	1
FIRST FLOOR PLAN	SPLIT A	FLAT	0.00	0.00	6	0
Total:	-	-	167.04	149.84	12	1

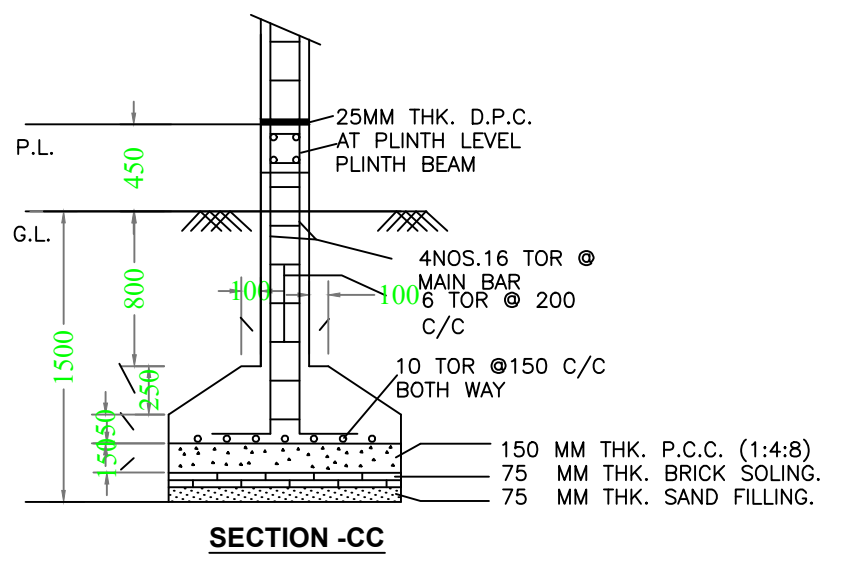
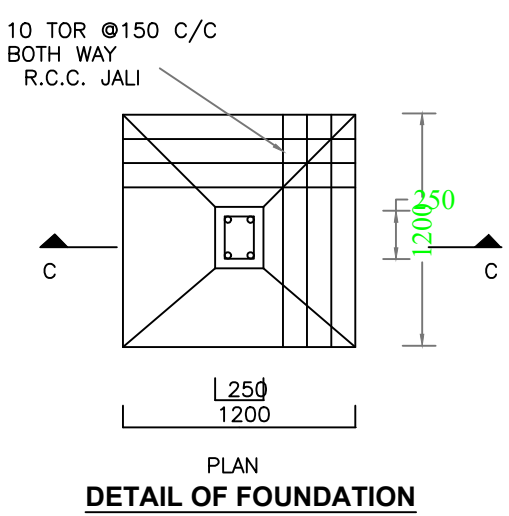
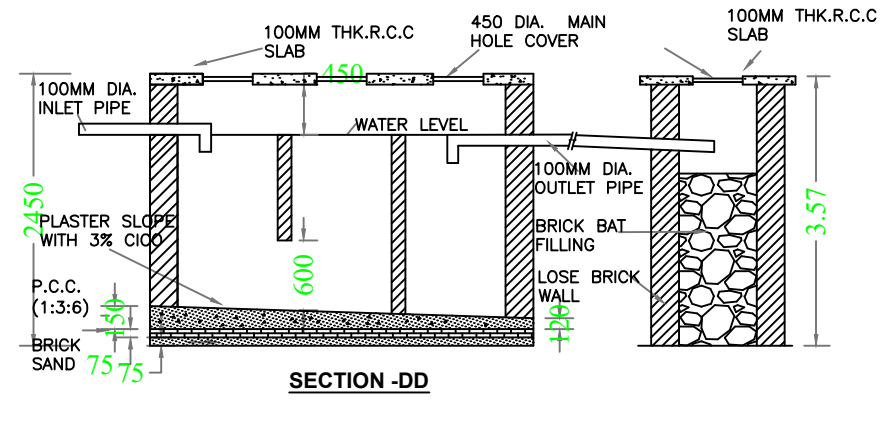

Building USE/SUBUSE Details

Building Name	Building Use	Building SubUse	Building Structure
A (ONILA KUJUR)	Residential	Bungalow/ Dwelling / Non Apartment	Non-Highrise

COLOR INDEX

PLOT BOUNDARY	Black
ABUTTING ROAD	Red
PROPOSED CONSTRUCTION	Green
COMMON PLOT	Blue
ROAD WIDENING AREA	Yellow
EXISTING (To be retained)	Orange
EXISTING (To be demolished)	Purple

LTP NAME AND SIGNATURE	STRUCTURAL ENG'S NAME AND SIGNATURE	BUILDER NAME AND SIGNATURE	DIGITAL SIGNATURE
DEEPAK DIWAN GUNPC/ARC/003/2017			