

Proposal Basic Information	
Proposal File No.	GUNPC/BP/0027/W02/2022
Owner Name	PRADIP KUMAR JHA
Khata No	2
Plot No	612
Village Name	Dundurya
Use	Residential
SubUse	Bungalow/ Dwelling / Non Apartment

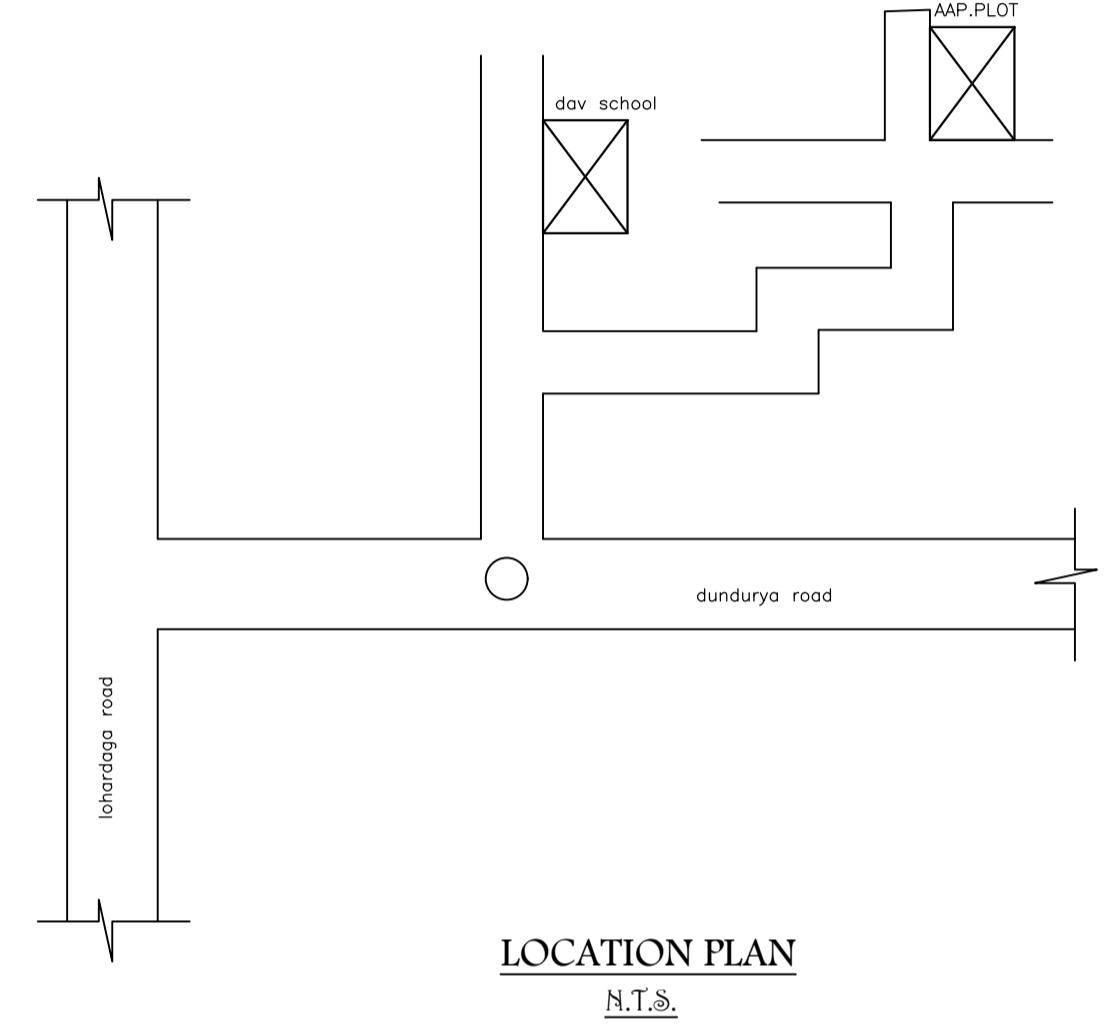
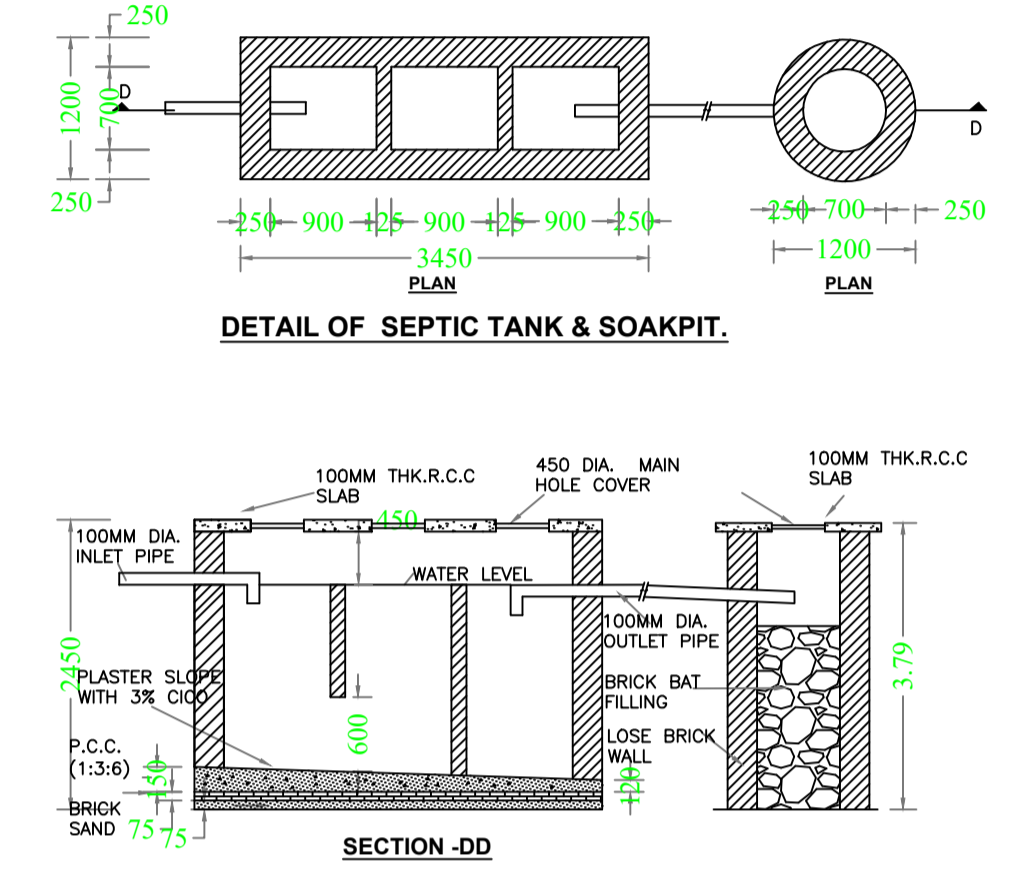
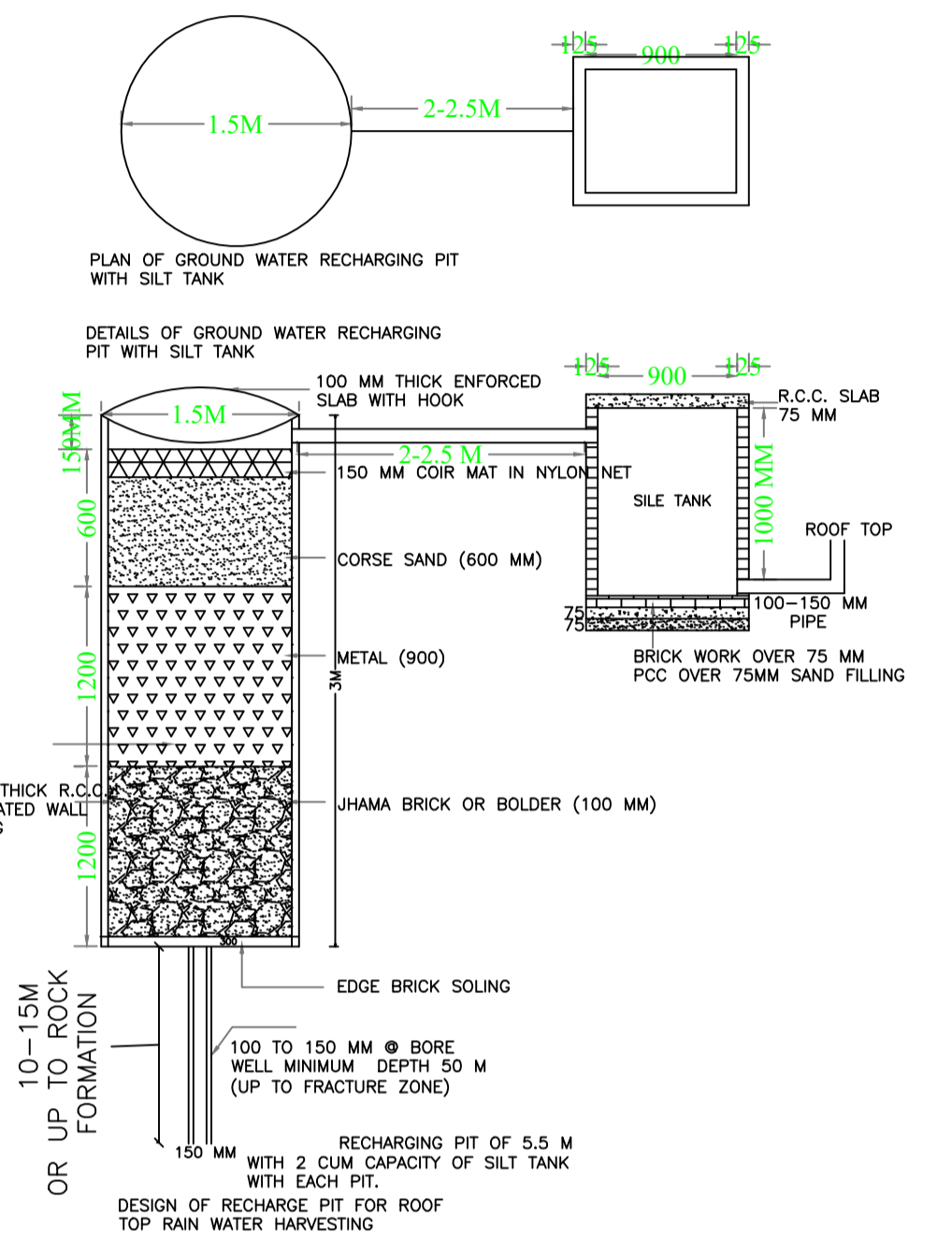
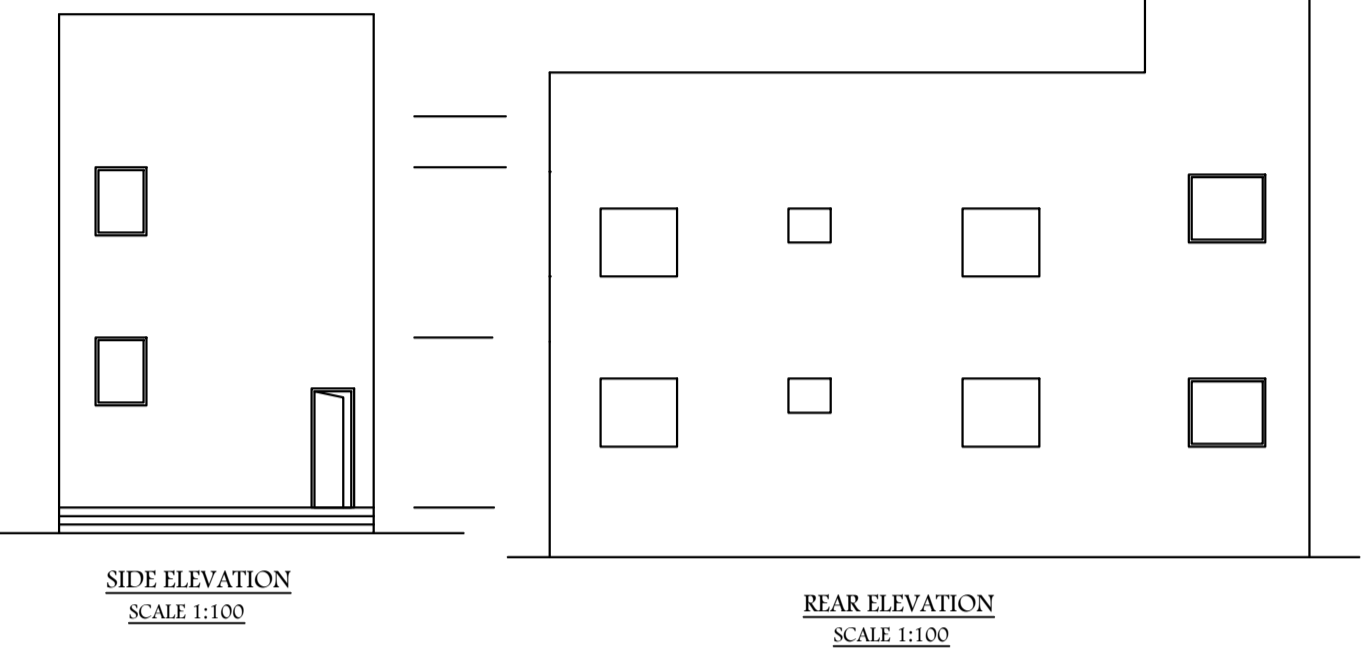
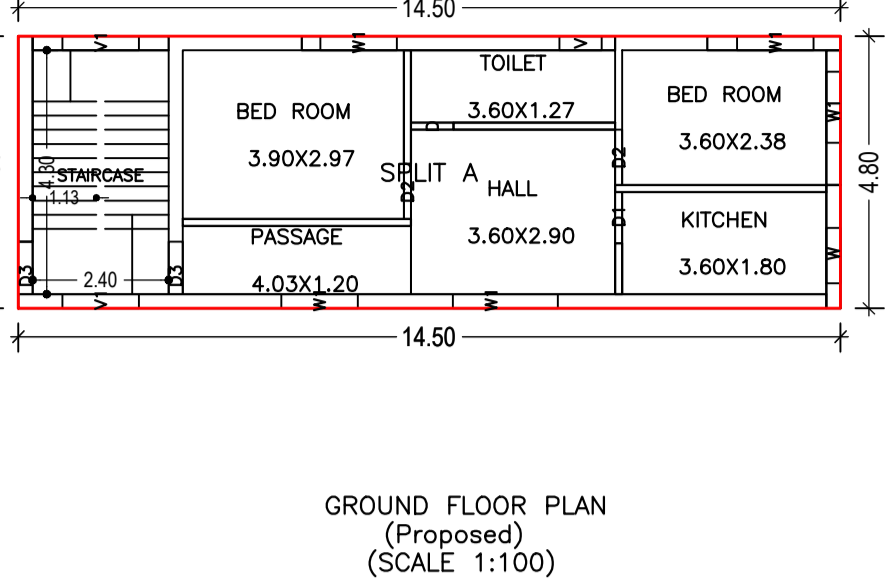
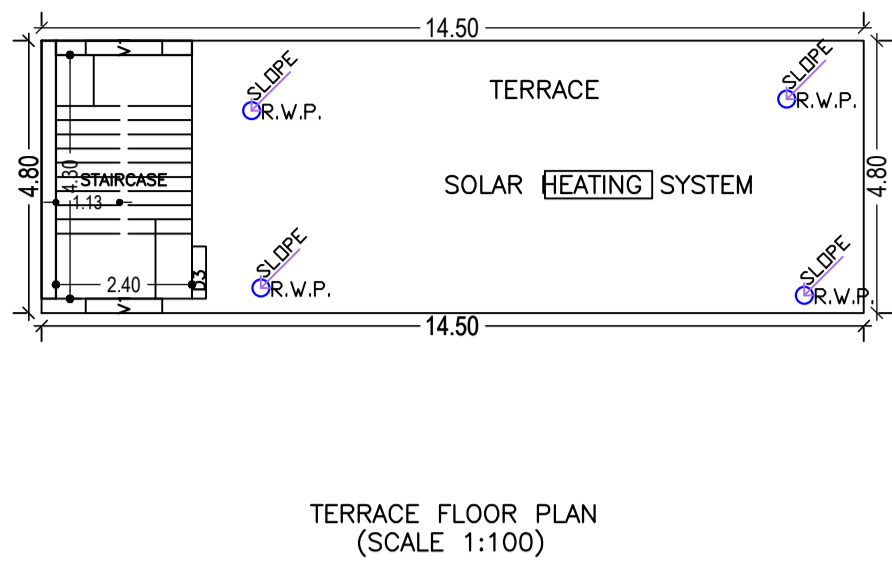
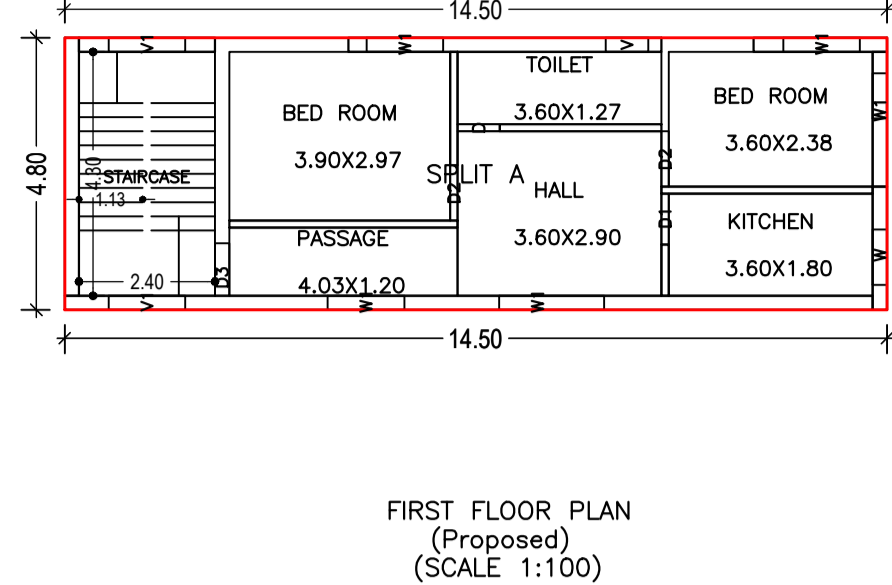
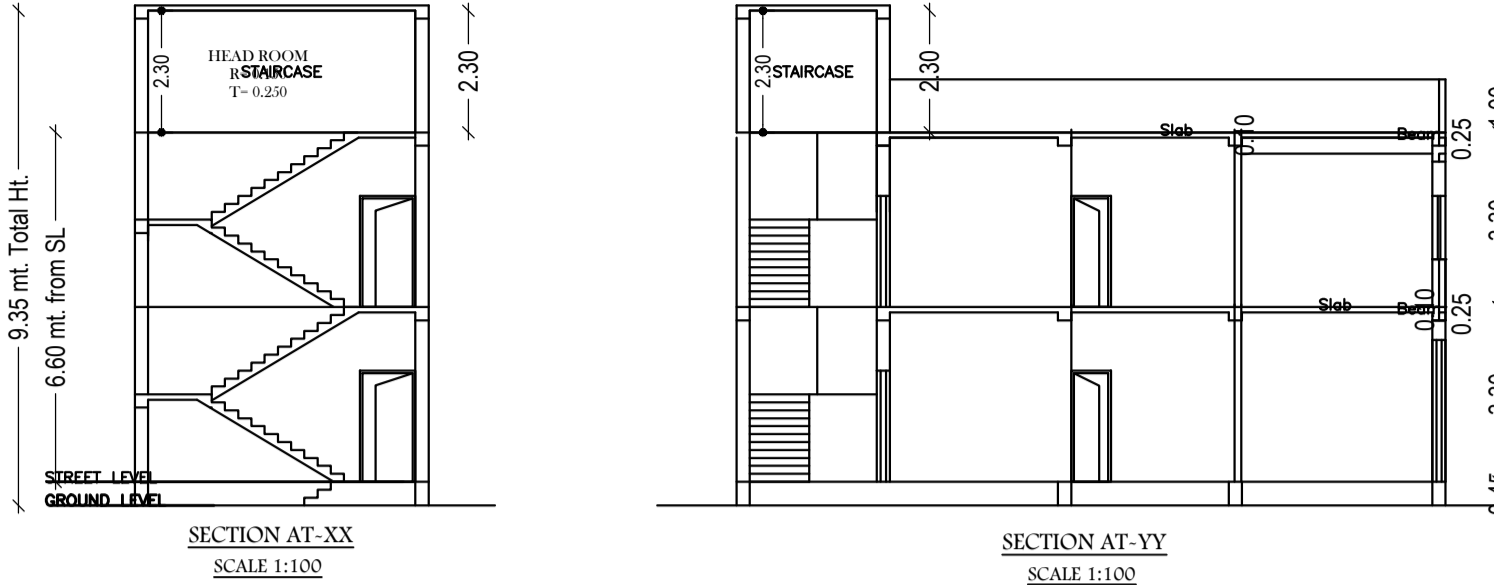

SCHEDULE OF DOOR:

BUILDING NAME	NAME	LENGTH	HEIGHT	NOS
A (PRADEEP KUMAR JHA)	D	0.75	2.10	02
A (PRADEEP KUMAR JHA)	D1	0.90	2.10	02
A (PRADEEP KUMAR JHA)	D3	0.93	2.10	02
A (PRADEEP KUMAR JHA)	D2	0.98	2.10	04

SCHEDULE OF WINDOW/VENTILATION:

BUILDING NAME	NAME	LENGTH	HEIGHT	NOS
A (PRADEEP KUMAR JHA)	V	0.75	0.60	02
A (PRADEEP KUMAR JHA)	W1	0.80	1.20	01
A (PRADEEP KUMAR JHA)	W	0.98	1.20	02
A (PRADEEP KUMAR JHA)	W1	1.26	1.20	01
A (PRADEEP KUMAR JHA)	W1	1.35	1.20	06
A (PRADEEP KUMAR JHA)	V1	1.35	1.20	06
A (PRADEEP KUMAR JHA)	W1	1.85	1.20	02

Building :A (PRADEEP KUMAR JHA)

Floor Name	Total Built Up Area (Sq.mt.)	Proposed FAR Area (Sq.mt.) Resi.	Total FAR Area (Sq.mt.)	Total Consumed Additional FAR Area (Sq.mt.)	Tnmt (No.)
Ground Floor	69.60	69.60	69.60	69.60	01
First Floor	69.60	69.60	69.60	69.60	00
Terrace Floor	0.00	0.00	0.00	0.00	00
Total	139.20	139.20	139.20	139.20	01
Total Number of Same Buildings	1				
Total :	139.20	139.20	139.20	139.20	01

UnitBUA Table for Building :A (PRADEEP KUMAR JHA)

FLOOR	Name	UnitBUA Type	UnitBUA Area	Carpet Area	No. of Rooms	No. of Tenement
FIRST FLOOR PLAN	SPLIT A	FLAT	0.00	0.00	6	0
GROUND FLOOR PLAN	SPLIT A	FLAT	139.20	119.24	6	1
Total	-	-	139.20	119.24	12	1

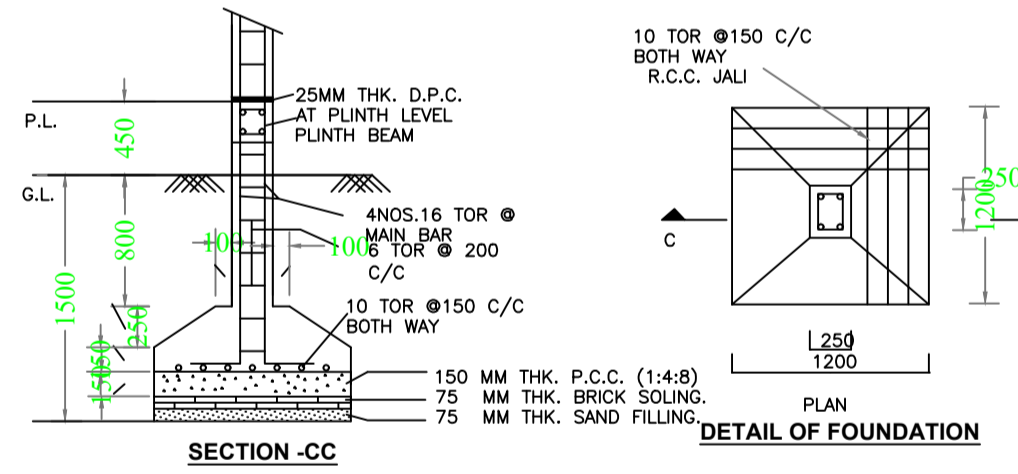

Building USE/SUBUSE Details

Building Name	Building Use	Building SubUse	Building Structure
A (PRADEEP KUMAR JHA)	Residential	Bungalow/ Dwelling / Non Apartment	Non-Highrise

Buildingwise Floor FAR Details

Floor Name	Building Name		Total	
	Proposed Built Up Area (Sq.mt.)	Proposed FAR Area (Sq.mt.)	Total Proposed Built Up Area (Sq.mt.)	Total FAR Area (Sq.mt.)
Ground Floor	69.60	69.60	69.60	69.60
First Floor	69.60	69.60	69.60	69.60
Terrace Floor	0.00	0.00	0.00	0.00
Total :	139.20	139.20	139.20	139.20

FAR & Tenement Details (Table 4c-1)

Building	No. of Same Bldg	Total Built Up Area (Sq.mt.)	Proposed FAR Area (Sq.mt.) Resi.	Total FAR Area (Sq.mt.)	Total Consumed Additional FAR Area (Sq.mt.)	Tnmt (No.)
A (PRADEEP KUMAR JHA)	1	139.20	139.20	139.20	139.20	01
Grand Total :	1	139.20	139.20	139.20	139.20	01

COLOR INDEX	
PLOT BOUNDARY	Black
ABUTTING ROAD	Red
PROPOSED CONSTRUCTION	Green
COMMON PLOT	Yellow
ROAD WIDENING AREA	Blue
EXISTING (To be retained)	Light Blue
EXISTING (To be demolished)	White

AREA STATEMENT GUMLA NAGAR PARISHAD		VERSION NO.: 1.0.62
PROJECT DETAIL:		VERSION DATE: 16/10/2020
Region: JHARKHAND URBAN LOCAL BODIES	Plot Use: Residential	
District: GUMLA	Plot SubUse: Bungalow/ Dwelling / Non Apartment	
Authority: GUMLA NAGAR PARISHAD	PlotNearbyReligiousStructure: NA	
Invend. No: GUNPC/BP/0027/W02/2022	Plot/SubPlot No: 612	
Application Type: General Proposal	North: -	
Project Type: Building Permission	South: -	
Nature of Development: New	East: -	
Location of Development Area: Old Area	West: -	
AREA DETAILS:		
AREA OF PLOT (Minimum)	(A)	SQ.MT.
NET AREA OF PLOT(Gross Plot Area - Deduction from Gross Plot area)	(A-Deductions)	195.75
Deduction for Balance Plot Area(from Gross Plot Area)		
Common Plot		13.15
BALANCE AREA OF PLOT(Net Plot Area - Recreational/Amenity space)		182.60
Plot Area FOR COVERAGE(Net Plot Area)	(A-Deductions)	195.75
Plot Area for FAR (Net Plot Area + RoadWidening Area)	(A-Deductions)	195.75
COVERAGE CHECK		
Permissible Coverage area ( 70.00 % )		137.02
Proposed Coverage Area ( 35.56 % )		69.60
Total Prop. Coverage Area ( 35.56 % )		69.60
Balance coverage area ( 34.44 % )		67.42
FAR CHECK		
Perm. FAR Area ( 1.50 )		293.63
Total Perm. FAR area		293.63
Residential FAR		139.20
Proposed FAR Area		139.20
Total Proposed FAR Area		139.20
Consumed FAR (Factor)		0.71
Balance FAR Area		154.43
BUILT UP AREA CHECK		
Total Proposed BuiltUp Area		139.20
ARCHITECT (Regd)	DEEPAK DIWAN	
ENGINEER (Regd)		
SUPERVISOR (Regd)		
OWNER (Regd)	PRADIP KUMAR JHA	
DEVELOPMENT AUTHORITY		LOCAL BODY

LTP NAME AND SIGNATURE	STRUCTURAL ENG'S NAME AND SIGNATURE	BUILDER NAME AND SIGNATURE	DIGITAL SIGNATURE
DEEPAK DIWAN GUNPC/ARC/0003/2017			