

Proposal Basic Information	
Proposal File No.	GUNPC/BI/0021/W14/2022
Owner Name	ROSHNI TIRKEY
Khata No	55
Plot No	1
Village Name	Karam Toi
Use	Residential
SubUse	Bungalow/ Dwelling / Non Apartment

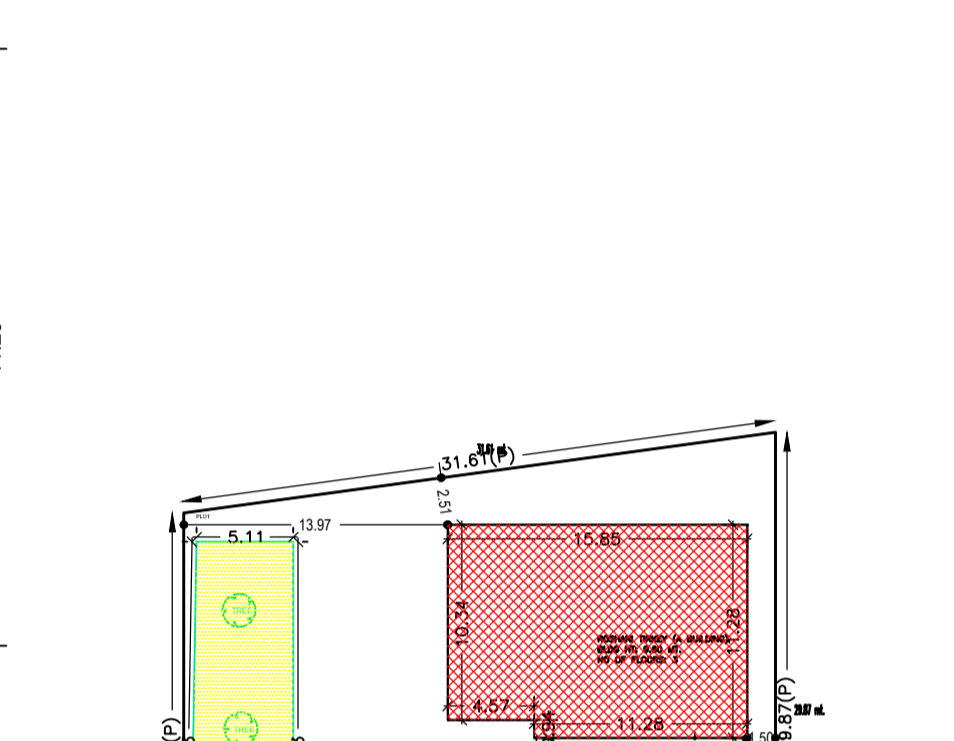
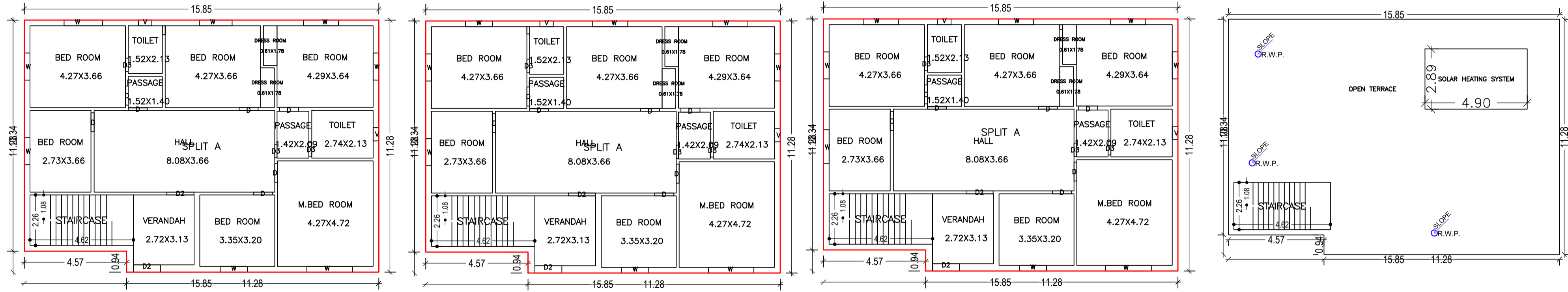
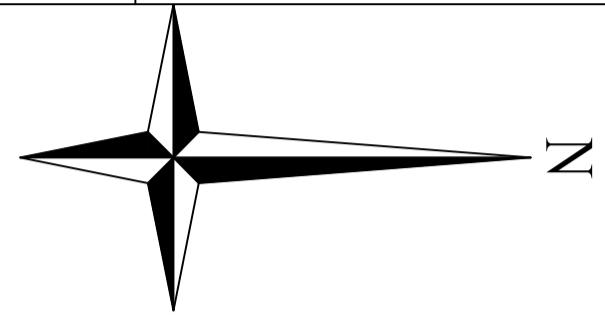

Building :ROSHANI TIRKEY (A BUILDING)

Floor Name	Total Built Up Area (Sq.mt.)	Proposed FAR Area (Sq.mt.) Resi.	Total FAR Area (Sq.mt.)	Total Consumed Additional FAR Area (Sq.mt.)	Tnmt (No.)
Ground Floor	174.45	174.45	174.45	174.45	01
First Floor	174.45	174.45	174.45	174.45	00
Second Floor	174.45	174.45	174.45	174.45	00
Terrace Floor	0.00	0.00	0.00	0.00	00
Total :	523.35	523.35	523.35	523.35	01

Buildingwise Floor FAR Details

Floor Name	ROSHANI TIRKEY (A BUILDING)		Total	
	Proposed Built Up Area (Sq.mt.)	Proposed FAR Area (Sq.mt.)	Total Proposed Built Up Area (Sq.mt.)	Total FAR Area (Sq.mt.)
Ground Floor	174.45	174.45	174.45	174.45
First Floor	174.45	174.45	174.45	174.45
Second Floor	174.45	174.45	174.45	174.45
Terrace Floor	0.00	0.00	0.00	0.00
Total :	523.35	523.35	523.35	523.35

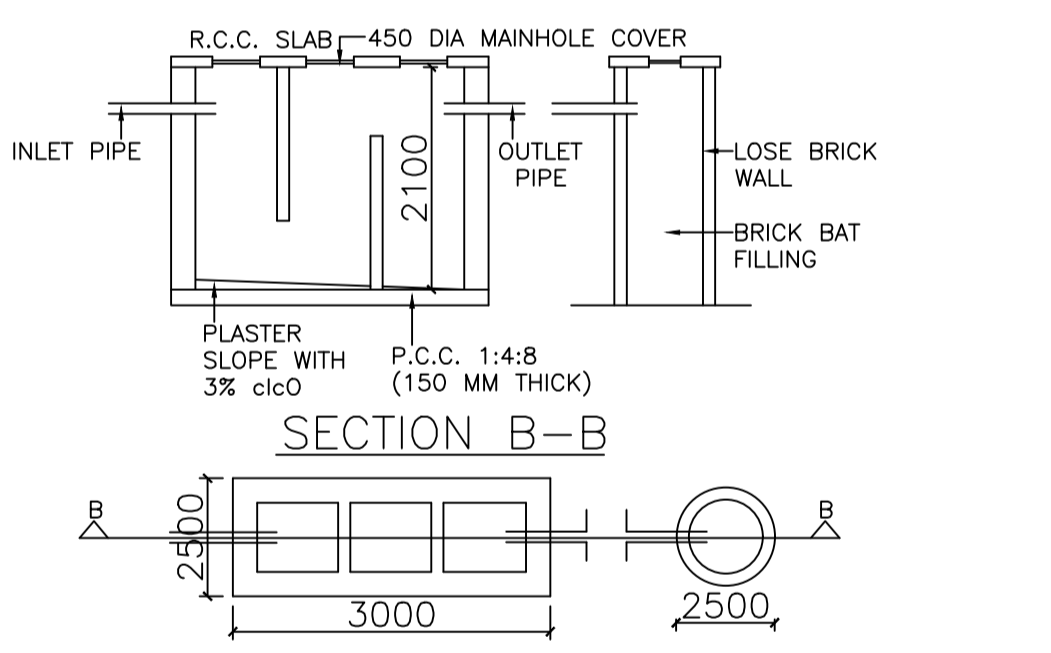

DETAIL OF SEPTIC TANK & SOAKPIT
Septic Tank Detail

SCHEDULE OF DOOR:

BUILDING NAME	NAME	LENGTH	HEIGHT	NOS
ROSHANI TIRKEY (A BUILDING)	D3	0.60	2.10	09
ROSHANI TIRKEY (A BUILDING)	D	0.85	2.10	21
ROSHANI TIRKEY (A BUILDING)	D2	1.21	2.10	06

SCHEDULE OF WINDOW/VENTILATION:

BUILDING NAME	NAME	LENGTH	HEIGHT	NOS
ROSHANI TIRKEY (A BUILDING)	V	0.60	1.20	06
ROSHANI TIRKEY (A BUILDING)	W	1.21	1.20	12
ROSHANI TIRKEY (A BUILDING)	W	1.47	1.20	01
ROSHANI TIRKEY (A BUILDING)	W	1.51	1.20	01
ROSHANI TIRKEY (A BUILDING)	W	1.57	1.20	06
ROSHANI TIRKEY (A BUILDING)	W	1.72	1.20	01
ROSHANI TIRKEY (A BUILDING)	W	2.03	1.20	01
ROSHANI TIRKEY (A BUILDING)	W	2.04	1.20	01
ROSHANI TIRKEY (A BUILDING)	W	2.06	1.20	01

UnitBUA Table for Building :ROSHANI TIRKEY (A BUILDING)

FLOOR	Name	UnitBUA Type	UnitBUA Area	Carpet Area	No. of Rooms	No. of Tenement
GROUND FLOOR PLAN	SPLIT A	FLAT	448.86	448.75	14	1
FIRST FLOOR PLAN	SPLIT A	FLAT	0.00	0.00	14	0
SECOND FLOOR PLAN	SPLIT A	FLAT	0.00	0.00	14	0
Total:	-	-	448.86	448.75	42	1

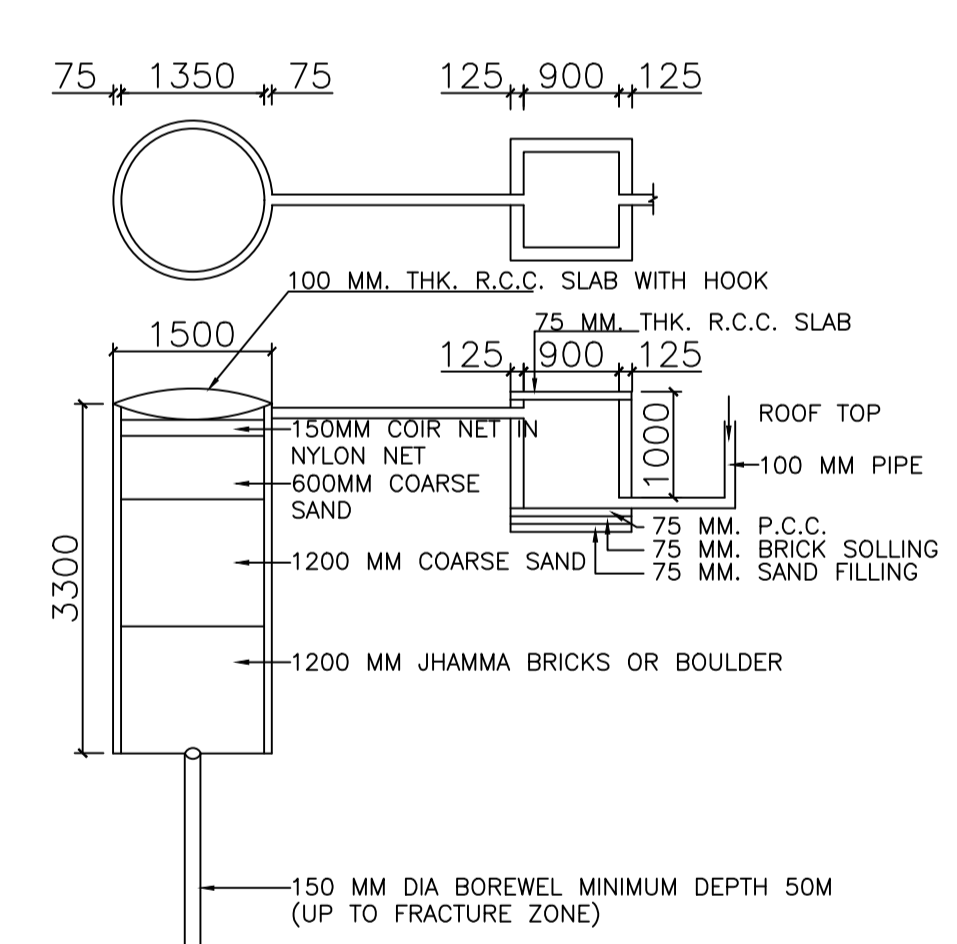

DETAIL OF GROUND WATER RECHARGE PIT WITH SILT TANK
Rain Water Storage Tank Detail

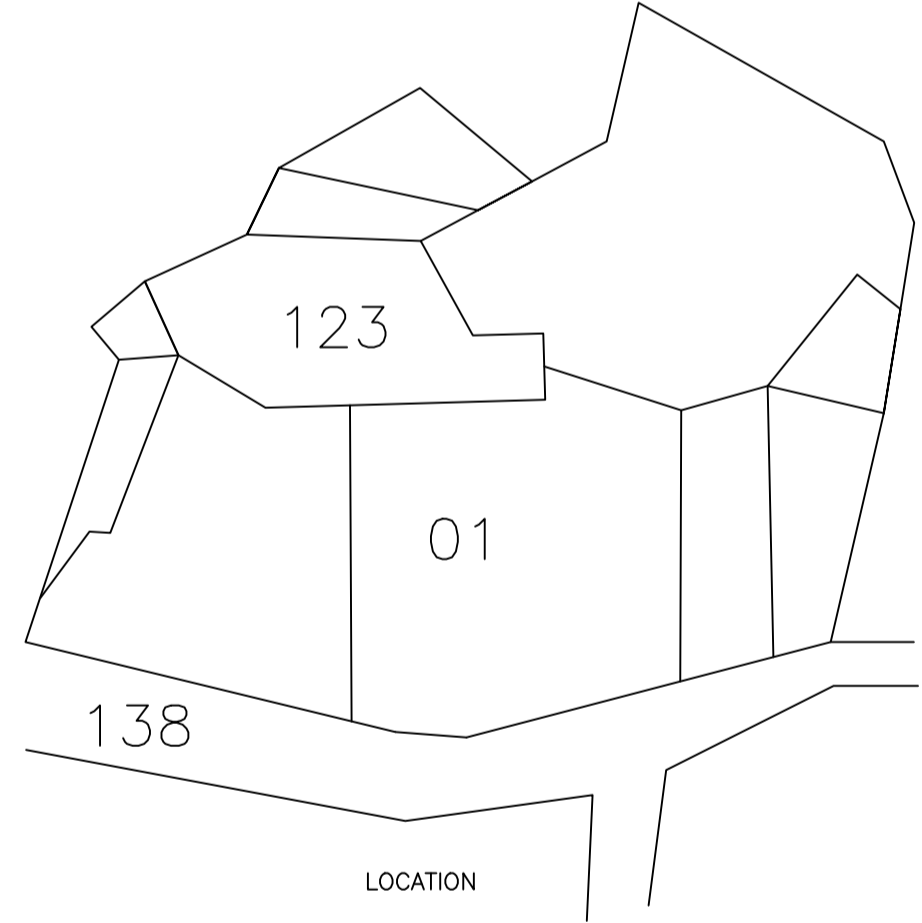

Building USE/SUBUSE Details

Building Name	Building Use	Building SubUse	Building Structure
ROSHANI TIRKEY (A BUILDING)	Residential	Bungalow/ Dwelling / Non Apartment	Non-Highrise

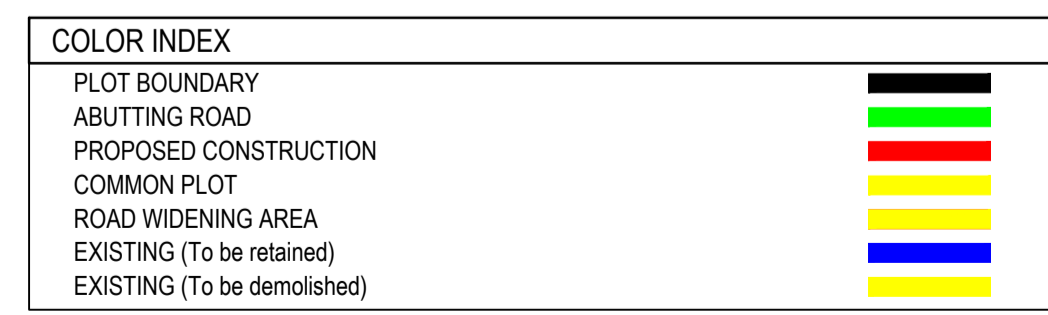

FAR & Tenement Details (Table 4c-1)

Building	No. of Same Bldg	Total Built Up Area (Sq.mt.)	Proposed FAR Area (Sq.mt.) Resi.	Total FAR Area (Sq.mt.)	Total Consumed Additional FAR Area (Sq.mt.)	Tnmt (No.)
ROSHANI TIRKEY (A BUILDING)	1	523.35	523.35	523.35	523.35	01
Grand Total :	1	523.35	523.35	523.35	523.35	01

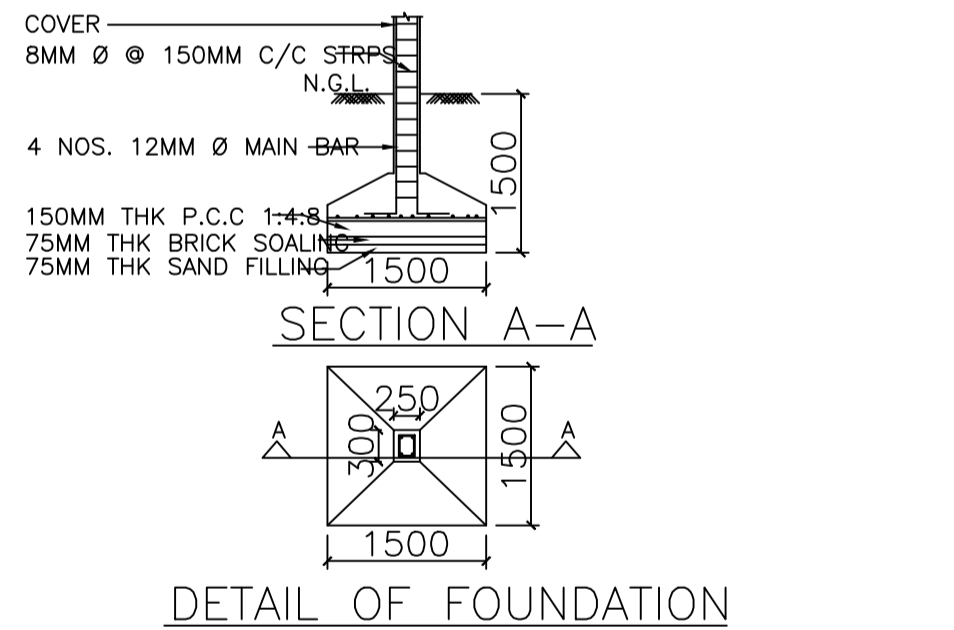

Structure Detail

AREA STATEMENT GUMLA NAGAR PARISHAD

VERSION NO.: 1.0.62
VERSION DATE: 16/10/2020

PROJECT DETAIL:

Region: JHARKHAND URBAN LOCAL BODIES	Plot Use: Residential
District: GUMLA	Plot SubUse: Bungalow/ Dwelling / Non Apartment
Authority: GUMLA NAGAR PARISHAD	PlotNearby/ReligiousStructure: NA
Inward No: GUNPC/BI/0021/W14/2022	Plot/SubPlot No: 1
Application Type: General Proposal	North: -
Project Type: Building Permission	South: -
Nature of Development: New	East: -
Location of Development Area: Old Area	West: -

AREA DETAILS:

AREA OF PLOT (Minimum)	(A)	SQ.MT.
NET AREA OF PLOT (Gross Plot Area - Deduction from Gross Plot area)	(A-Deductions)	868.67
Deduction for Balance Plot Area (from Gross Plot Area)		
Common Plot		122.83
Total		122.83
BALANCE AREA OF PLOT (Net Plot Area - Recreational/Amenity space)	(A-Deductions)	745.83
PLOT AREA FOR COVERAGE (Net Plot Area)	(A-Deductions)	868.67
Plot Area for FAR (Net Plot Area + Road Widening Area)	(A-Deductions)	868.67

COVERAGE CHECK

Permissible Coverage area (60.00 %)	521.20
Proposed Coverage Area (20.08 %)	174.45
Total Prop. Coverage Area (20.08 %)	174.45
Balance coverage area (39.92 %)	346.75

FAR CHECK

Perm. FAR Area (1.50)	1303.01
Total Perm. FAR area	1303.01
Residential FAR	523.35
Proposed FAR Area	523.35
Total Proposed FAR Area	523.35
Consumed FAR (Factor)	0.60
Balance FAR Area	779.66

BUILT UP AREA CHECK

Total Proposed BuiltUp Area	523.35
ARCHITECT (Regd)	RAWNIT KUMAR
ENGINEER (Regd)	
SUPERVISOR (Regd)	
OWNER (Regd)	ROSHNI TIRKEY
DEVELOPMENT AUTHORITY	LOCAL BODY

LTP NAME AND SIGNATURE	STRUCTURAL ENG'S NAME AND SIGNATURE	BUILDER NAME AND SIGNATURE	DIGITAL SIGNATURE
RAWNIT KUMAR GUNPC/ENG/0004/2019			