

Proposal Basic Information	
Proposal File No.	GUNPC/BP/0049/W04/2022
Owner Name	KAILASH RAM
Khata No	20
Plot No	611
Village Name	Chetar
Use	Residential
SubUse	Bungalow/ Dwelling / Non Apartment

FAR & Tenement Details (Table 4c-1)

Building	No. of Same Bldg	Total Built Up Area (Sq.mt.)	Proposed FAR Area (Sq.mt.)	Total FAR Area (Sq.mt.)	Total Consumed Additional FAR Area (Sq.mt.)	Trmt (No.)
KAILASH RAM (A BUILDING)	1	214.04	214.04	214.04	214.04	01
Grand Total :	1	214.04	214.04	214.04	214.04	01

SCHEDULE OF DOOR:

BUILDING NAME	NAME	LENGTH	HEIGHT	NOS
KAILASH RAM (A BUILDING)	D	0.97	2.10	28

SCHEDULE OF WINDOW/VENTILATION:

BUILDING NAME	NAME	LENGTH	HEIGHT	NOS
KAILASH RAM (A BUILDING)	V	0.60	1.20	08
KAILASH RAM (A BUILDING)	W	1.27	1.20	16
KAILASH RAM (A BUILDING)	W4	1.40	1.20	02
KAILASH RAM (A BUILDING)	W5	1.50	1.20	02

Buildingwise Floor FAR Details

Floor Name	Building Name		Total	
	Proposed Built Up Area (Sq.mt.)	Proposed FAR Area (Sq.mt.)	Total Proposed Built Up Area (Sq.mt.)	Total FAR Area (Sq.mt.)
Ground Floor	107.02	107.02	107.02	107.02
First Floor	107.02	107.02	107.02	107.02
Terrace Floor	0.00	0.00	0.00	0.00
Total :	214.04	214.04	214.04	214.04

AREA STATEMENT GUMLA NAGAR PARISHAD		VERSION NO. : 1.0.65
PROJECT DETAIL:		VERSION DATE: 16/10/2020
Region: JHARKHAND URBAN LOCAL BODIES	Plot Use: Residential	
District: GUMLA	Plot SubUse: Bungalow/ Dwelling / Non Apartment	
Authority: GUMLA NAGAR PARISHAD	PlotNearby/ReligiousStructure: NA	
Inward No: GUNPC/BP/0049/W04/2022	Plot/SubPlot No: 611	
Application Type: General Proposal	North: -	
Project Type: Building Permission	South: -	
Nature of Development: New	East: -	
Location of Development Area: Old Area	West: -	
AREA DETAILS:		SQ.MT.
AREA OF PLOT (Minimum)	(A)	770.31
Deduction for NetPlot Area		
Surrender Free of Cost		0.29
Total		0.29
NET AREA OF PLOT(Gross Plot Area - Deduction from Gross Plot area)	(A-Deductions)	770.02
Deduction for Balance Plot Area(from Gross Plot Area)		
Surrender Free of Cost		0.29
Common Plot		84.55
Total		84.84
BALANCE AREA OF PLOT(Net Plot Area - Recreational/Amenity space)	(A-Deductions)	685.47
PLOT AREA FOR COVERAGE(Net Plot Area)	(A-Deductions)	770.02
Plot Area for FAR (Net Plot Area + Road/Widening Area)	(A-Deductions)	770.31
COVERAGE CHECK		
Permissible Coverage area (60.00 %)		462.01
Proposed Coverage Area (13.90 %)		107.02
Total Prop. Coverage Area (13.9 %)		107.02
Balance coverage area (46.10 %)		354.99
FAR CHECK		
Perm. FAR Area (1.200)		924.37
Total Perm. FAR area		924.37
Residential FAR		214.04
Proposed FAR Area		214.04
Total Proposed FAR Area		214.04
Consumed FAR (Factor)		0.28
Balance FAR Area		710.33
BUILT UP AREA CHECK		
Total Proposed BuiltUp Area		214.04
ARCHITECT (Regd)		RAWNIT KUMAR
ENGINEER (Regd)		
SUPERVISOR (Regd)		
OWNER (Regd)		KAILASH RAM
DEVELOPMENT AUTHORITY		LOCAL BODY

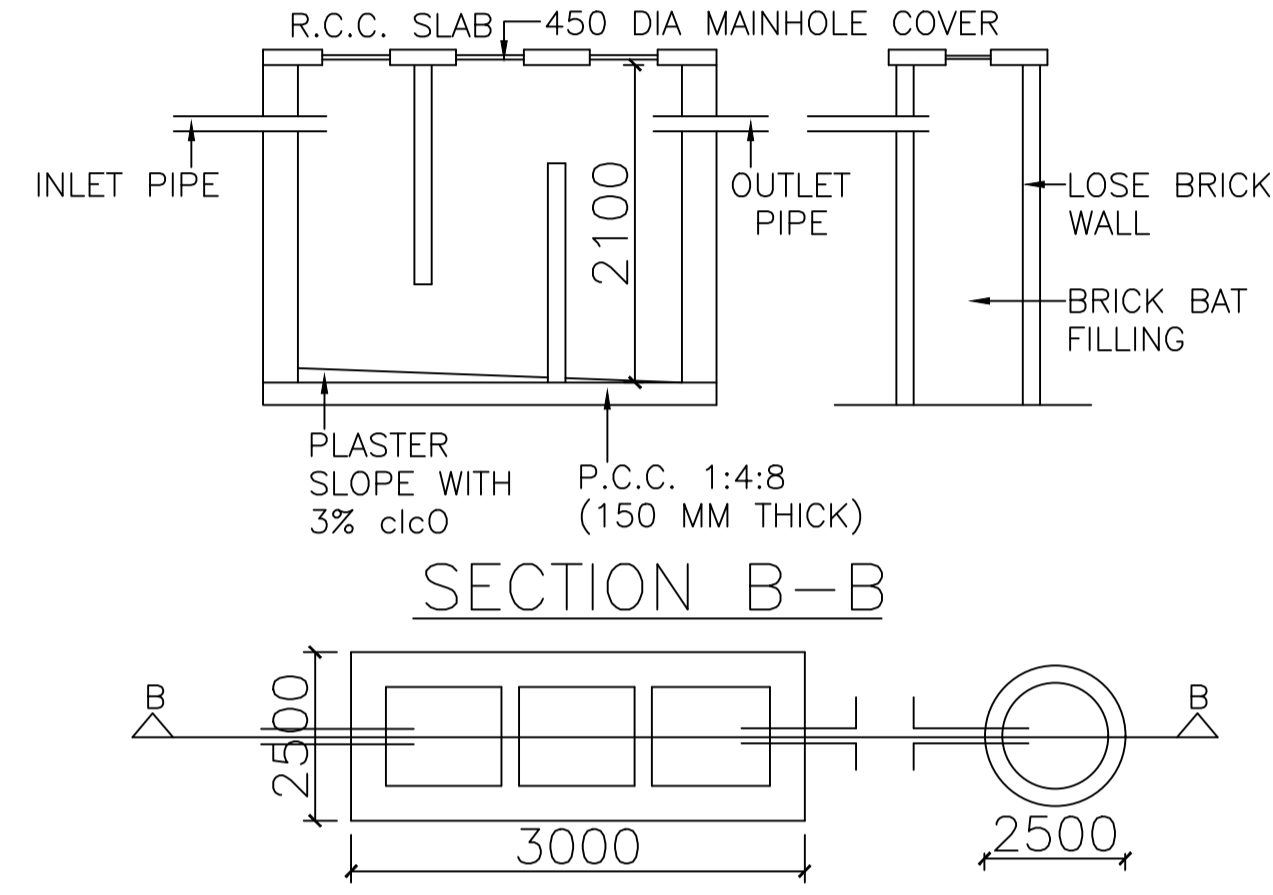
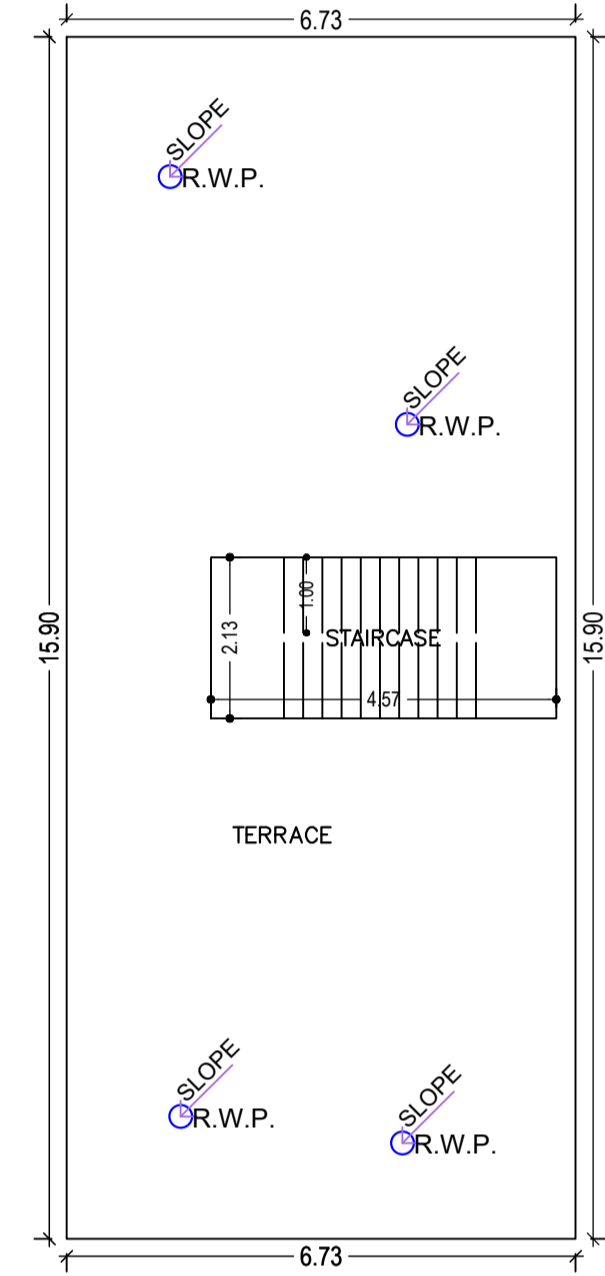
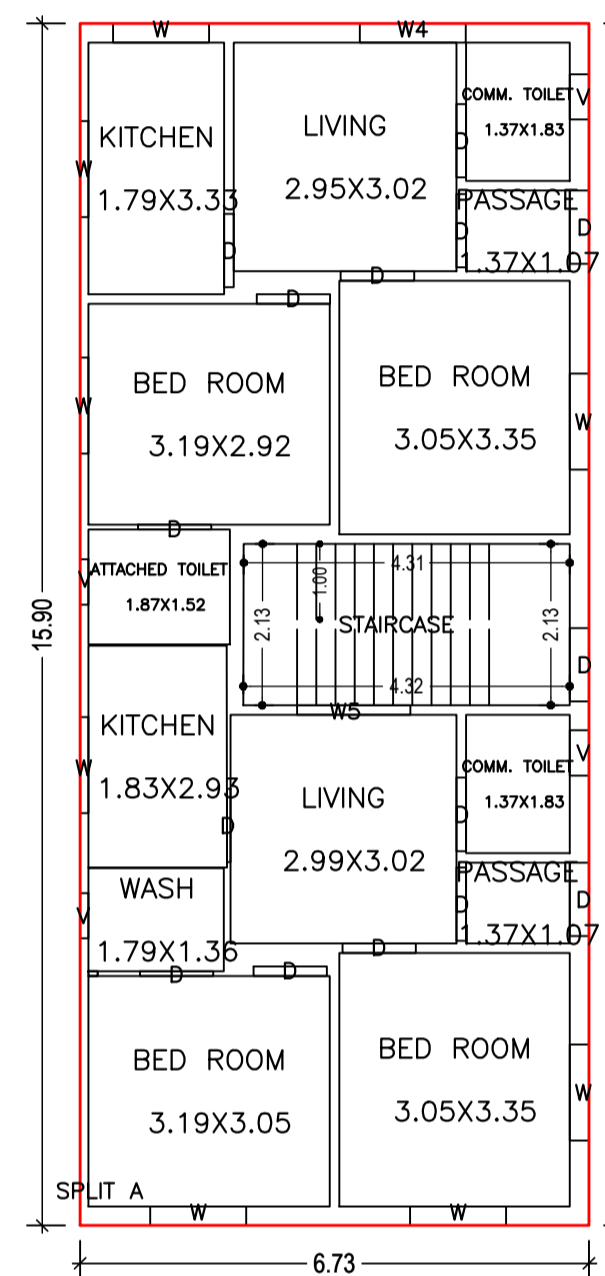
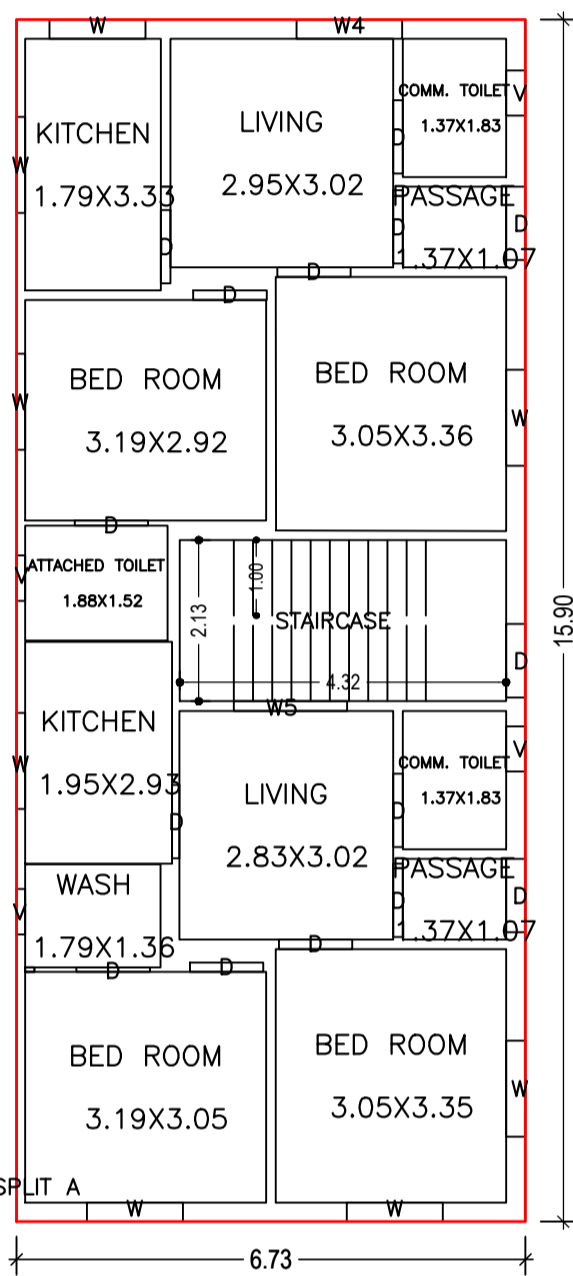

DETAIL OF SEPTIC TANK & SOAKPIT
Septic Tank Detail

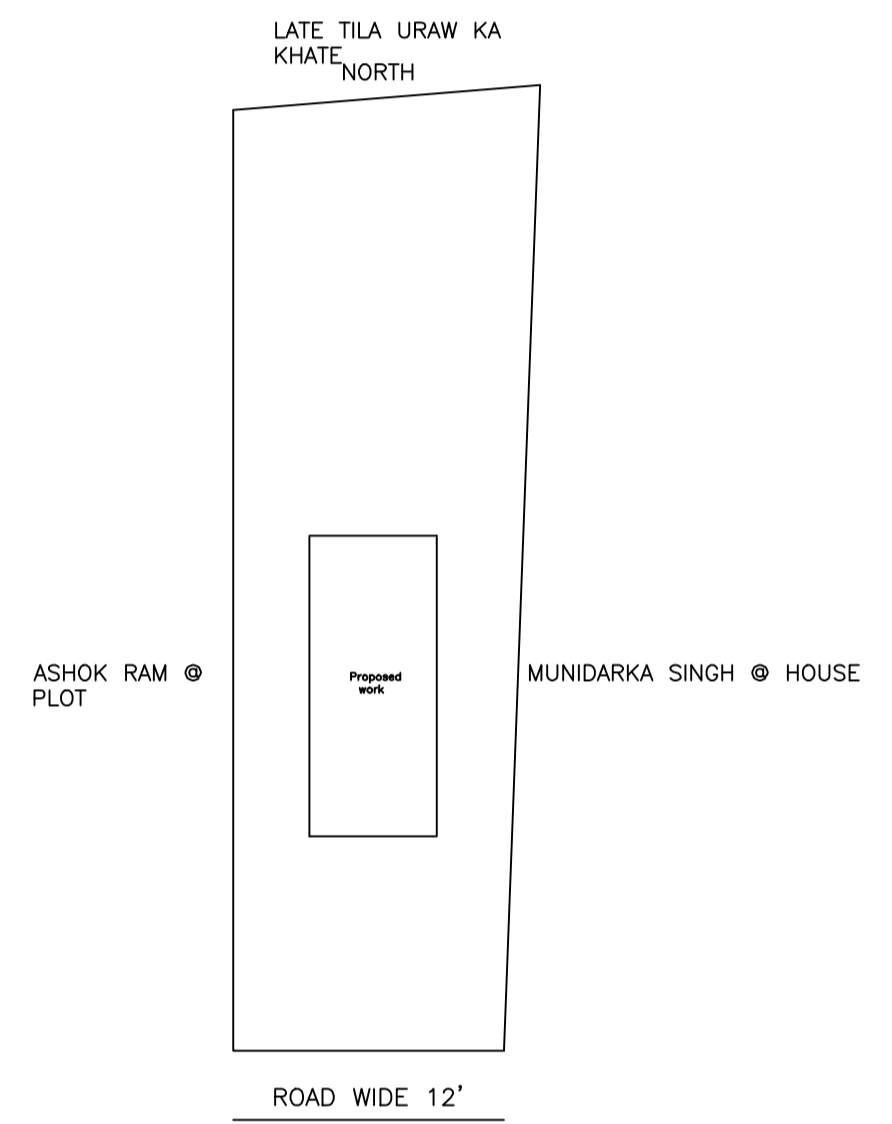

FIRST FLOOR PLAN (Proposed) (SCALE 1:100)

GROUND FLOOR PLAN (Proposed) (SCALE 1:100)

TERRACE FLOOR PLAN (SCALE 1:100)

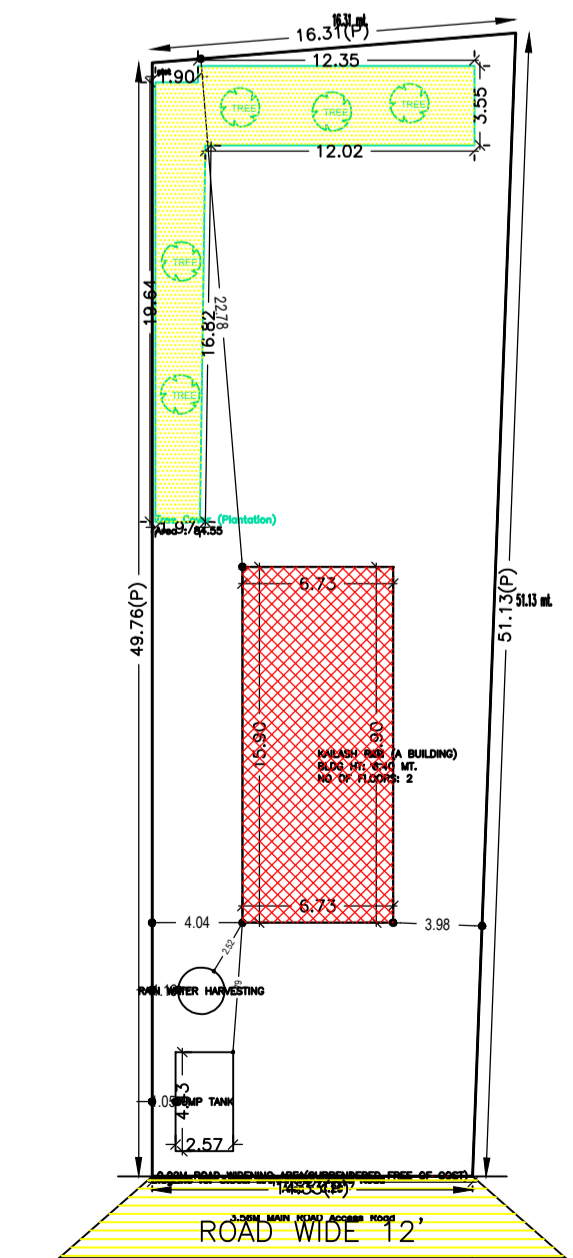

Structure Detail

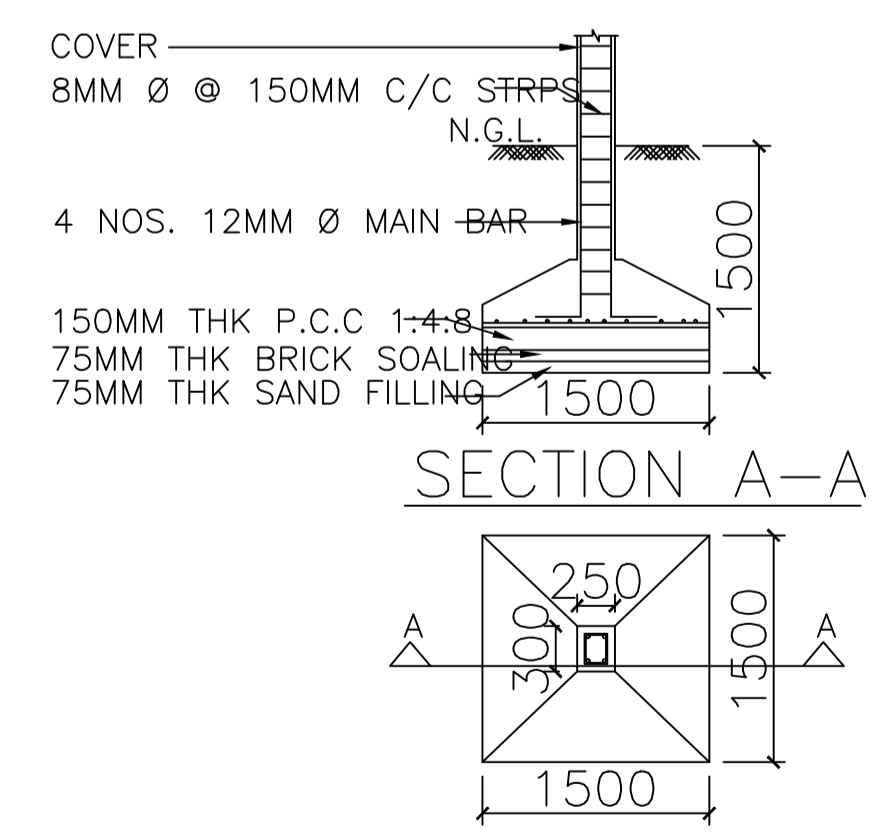

DETAIL OF FOUNDATION

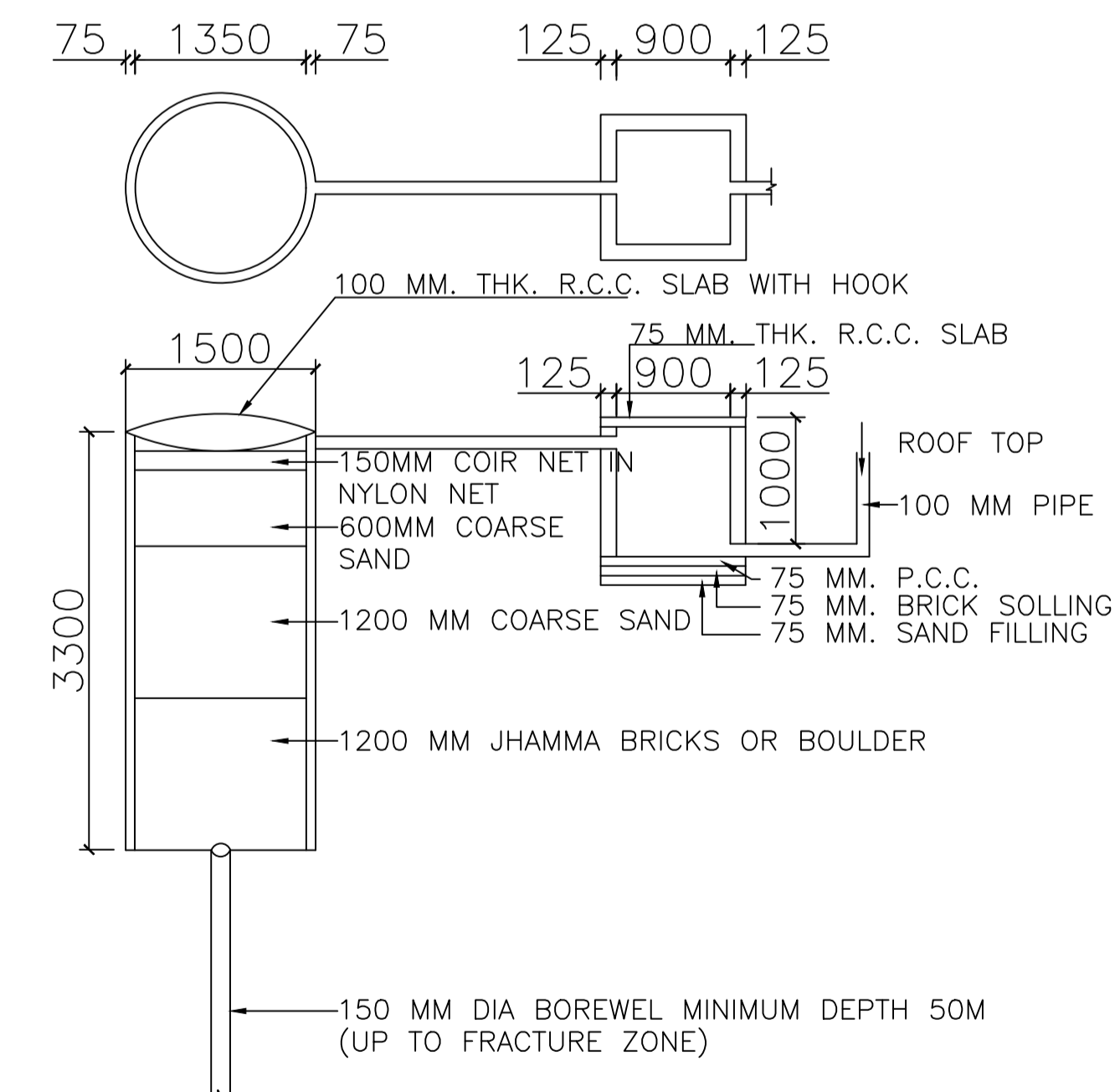

DETAIL OF GROUND WATER RECHARGE PIT WITH SILT TANK

Rain Water Storage Tank Detail

UnitBUA Table for Building :KAILASH RAM (A BUILDING)

FLOOR	Name	UnitBUA Type	UnitBUA Area	Carpet Area	No. of Rooms	No. of Tenement
GROUND FLOOR PLAN	SPLIT A	FLAT	175.40	175.38	14	1
FIRST FLOOR PLAN	SPLIT A	FLAT	0.00	0.00	14	0
Total:	-	-	175.40	175.38	28	1

Building :KAILASH RAM (A BUILDING)

Floor Name	Total Built Up Area (Sq.mt.)	Proposed FAR Area (Sq.mt.)	Total FAR Area (Sq.mt.)	Total Consumed Additional FAR Area (Sq.mt.)	Trmt (No.)
Ground Floor	107.02	107.02	107.02	107.02	01
First Floor	107.02	107.02	107.02	107.02	00
Terrace Floor	0.00	0.00	0.00	0.00	00
Total :	214.04	214.04	214.04	214.04	01
Total Number of Same Buildings	1				
Total :	214.04	214.04	214.04	214.04	01

Building USE/SUBUSE Details

Building Name	Building Use	Building SubUse	Building Structure
KAILASH RAM (A BUILDING)	Residential	Bungalow/ Dwelling / Non Apartment	Non-Highrise

LTP NAME AND SIGNATURE	STRUCTURAL ENG'S NAME AND SIGNATURE	BUILDER NAME AND SIGNATURE	DIGITAL SIGNATURE
RAWNIT KUMAR GUNPC/ENG/0004/2019			