

Proposal Basic Information

Proposal File No.	GUNPC/BP/0045/W11/2022
Owner Name	YOTAM TOPPO
Khata No	77
Plot No	1499
Village Name	Shanti Nagar
Use	Residential
SubUse	Bungalow/ Dwelling / Non Apartment

Building USE/SUBUSE Details

Building Name	Building Use	Building SubUse	Building Structure
YOTAM TOPPO (A BUILDING)	Residential	Bungalow/ Dwelling / Non Apartment	Non-Highrise

FAR & Tenement Details (Table 4c-1)

Building	No. of Same Bldg	Total Built Up Area (Sq.mt.)	Proposed FAR Area (Sq.mt.)	Total FAR Area (Sq.mt.)	Total Consumed Additional FAR Area (Sq.mt.)	Tnmt (No.)
YOTAM TOPPO (A BUILDING)	1	213.12	213.12	213.12	213.12	01
Grand Total:	1	213.12	213.12	213.12	213.12	01

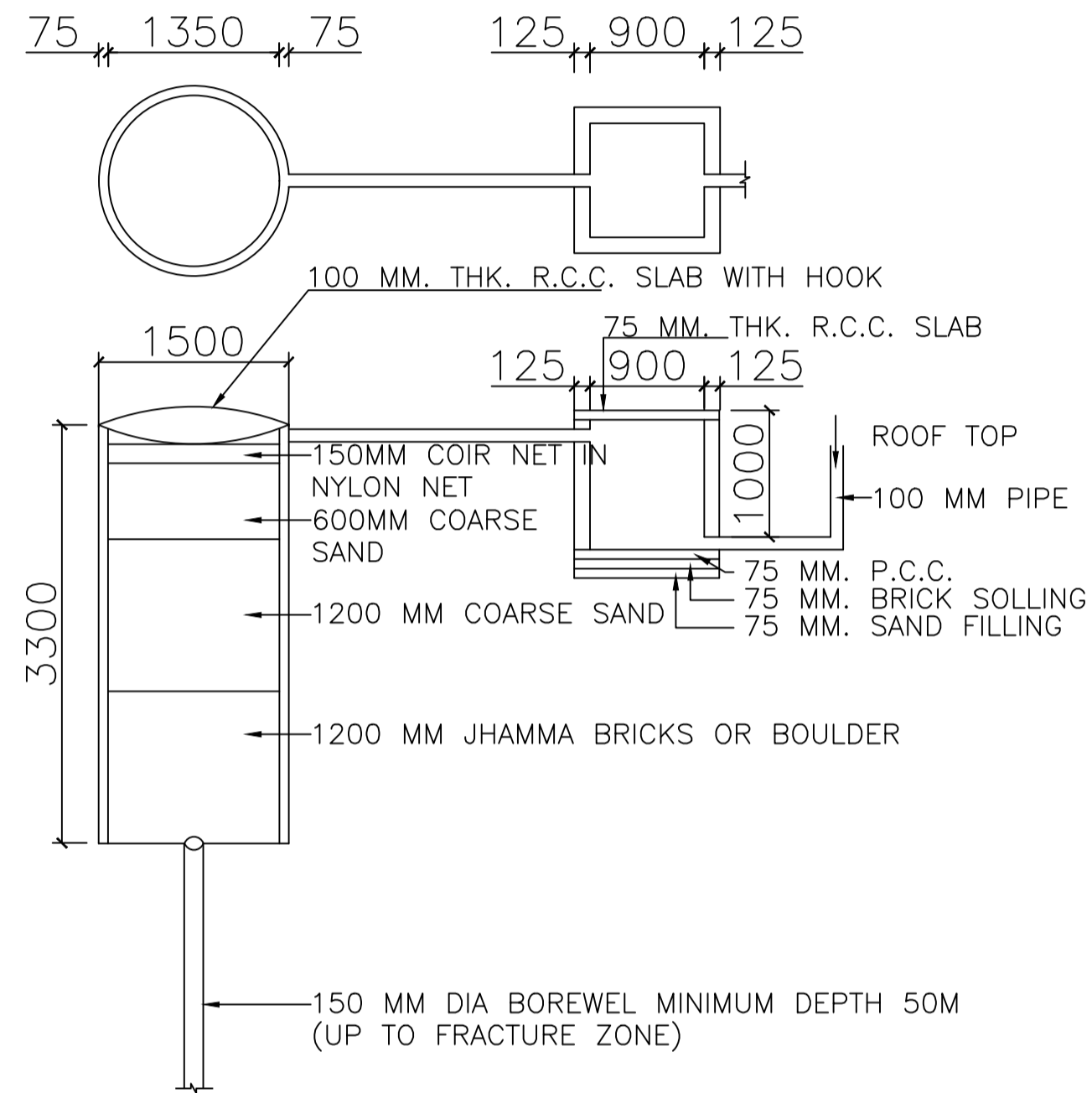
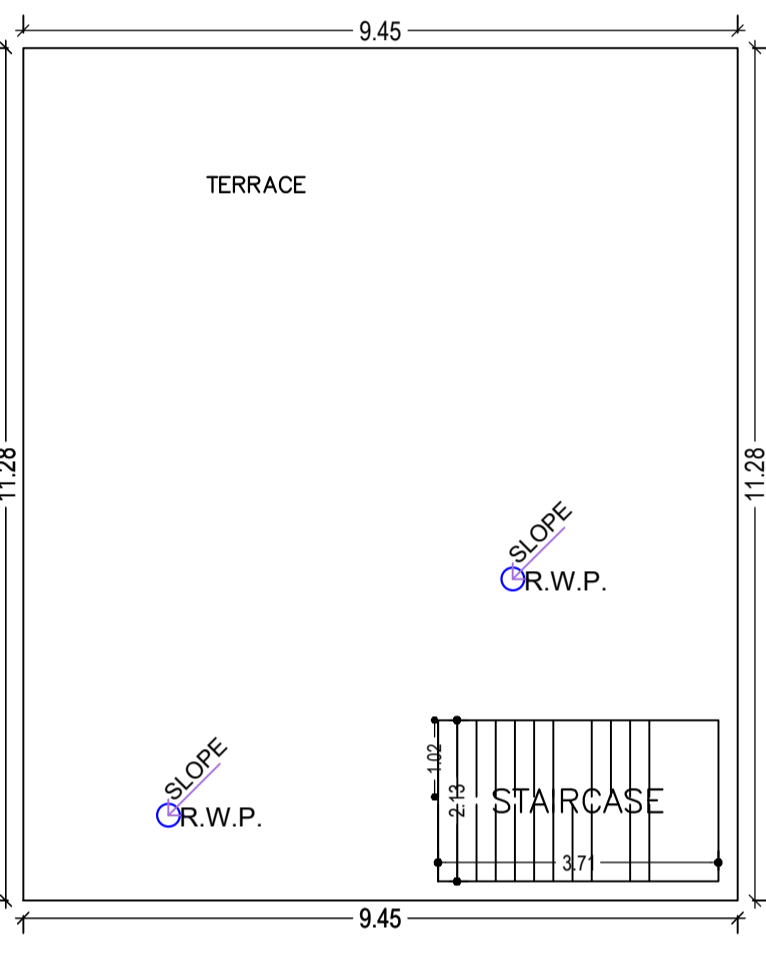
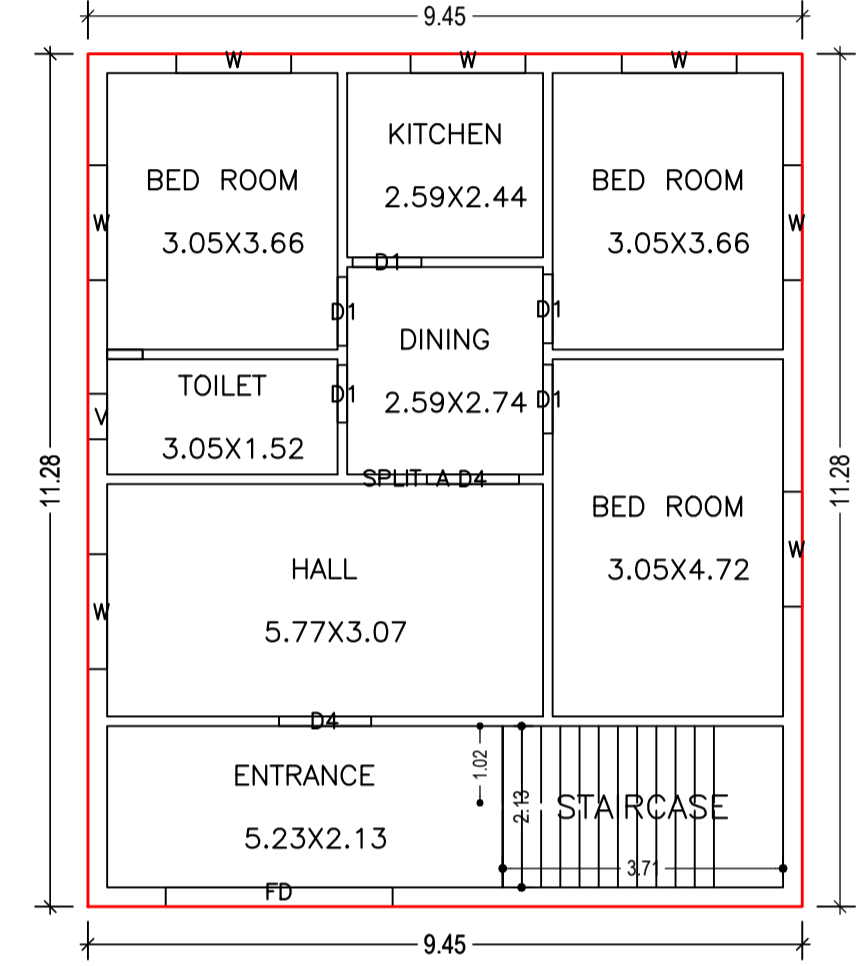
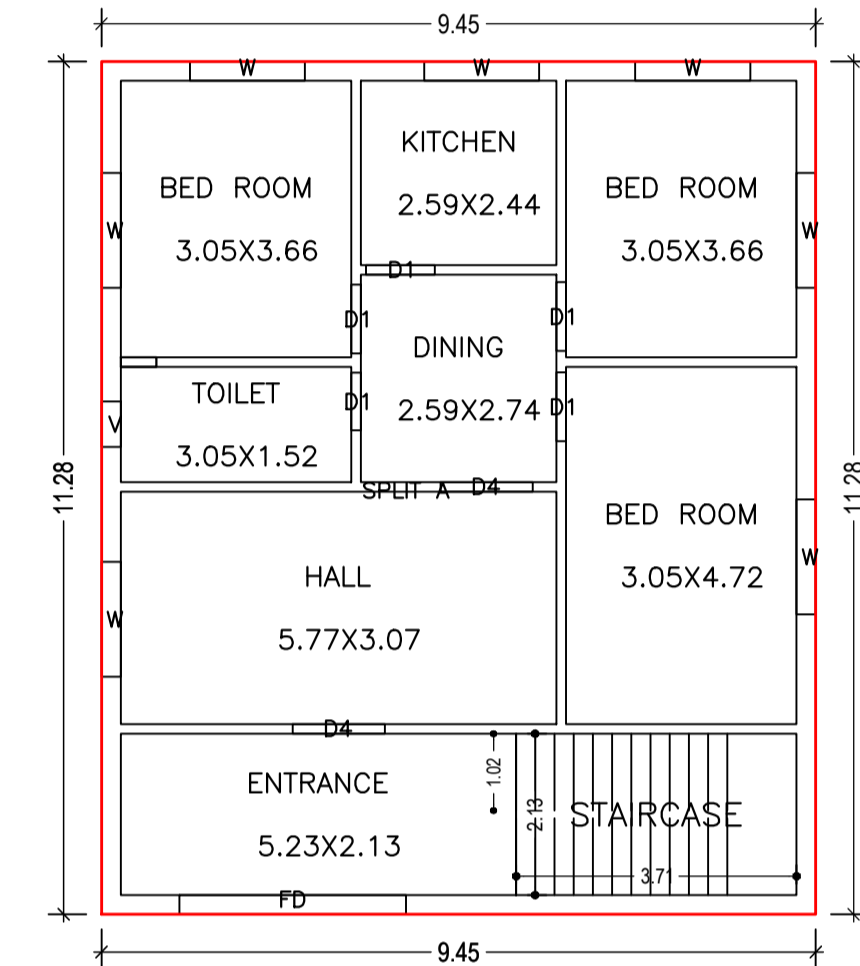

Buildingwise Floor FAR Details

Floor Name	Building Name		Total	
	YOTAM TOPPO (A BUILDING)	Proposed FAR Area (Sq.mt.)	Total Proposed Built Up Area (Sq.mt.)	Total FAR Area (Sq.mt.)
Ground Floor	106.56	106.56	106.56	106.56
First Floor	106.56	106.56	106.56	106.56
Terrace Floor	0.00	0.00	0.00	0.00
Total :	213.12	213.12	213.12	213.12

Building :YOTAM TOPPO (A BUILDING)

Floor Name	Total Built Up Area (Sq.mt.)	Proposed FAR Area (Sq.mt.)	Total FAR Area (Sq.mt.)	Total Consumed Additional FAR Area (Sq.mt.)	Tnmt (No.)
Ground Floor	106.56	106.56	106.56	106.56	01
First Floor	106.56	106.56	106.56	106.56	00
Terrace Floor	0.00	0.00	0.00	0.00	00
Total :	213.12	213.12	213.12	213.12	01

AREA STATEMENT GUMLA NAGAR PARISHAD

VERSION NO.: 1.0.65
VERSION DATE: 16/10/2020

PROJECT DETAIL:

Region: JHARKHAND URBAN LOCAL BODIES
District: GUMLA
Authority: GUMLA NAGAR PARISHAD
Inward No: GUNPC/BP/0045/W11/2022
Application Type: General Proposal
Project Type: Building Permission
Nature of Development: New
Location of Development Area: Old Area

Plot Use: Residential
Plot SubUse: Bungalow/ Dwelling / Non Apartment
PlotNearbyReligiousStructure: NA
Plot/SubPlot No: 1499
North: -
South: -
East: -
West: -

AREA DETAILS:	AREA	SQ.MT.
AREA OF PLOT (Minimum)	(A)	202.13
NET AREA OF PLOT(Gross Plot Area - Deduction from Gross Plot area)	(A-Deductions)	202.13
Deduction for Balance Plot Area(from Gross Plot Area)		
Common Plot		20.73
Total		20.73
BALANCE AREA OF PLOT(Net Plot Area - Recreational/Amenity space)	(A-Deductions)	181.40
PLOT AREA FOR COVERAGE(Net Plot Area)	(A-Deductions)	202.13
Plot Area for FAR (Net Plot Area + RoadWidening Area)	(A-Deductions)	202.13
COVERAGE CHECK		
Permissible Coverage area (70.00 %)		141.49
Proposed Coverage Area (52.72 %)		106.56
Total Prop. Coverage Area (52.72 %)		106.56
Balance coverage area (17.28 %)		34.93
FAR CHECK		
Perm. FAR Area (1.500)		303.20
Total Perm. FAR area		303.20
Residential FAR		213.12
Proposed FAR Area		213.12
Total Proposed FAR Area		213.12
Consumed FAR (Factor)		1.05
Balance FAR Area		90.08
BUILT UP AREA CHECK		
Total Proposed BuiltUp Area		213.12
ARCHITECT (Regd)		
ARCHITECT (Regd)	RAWNIT KUMAR	
ENGINEER (Regd)		
ENGINEER (Regd)		
SUPERVISOR (Regd)		
SUPERVISOR (Regd)		
OWNER (Regd)		
OWNER (Regd)	YOTAM TOPPO	
DEVELOPMENT AUTHORITY		
DEVELOPMENT AUTHORITY	LOCAL BODY	

DETAIL OF GROUND WATER RECHARGE PIT WITH SILT TANK

Rain Water Storage Tank Detail

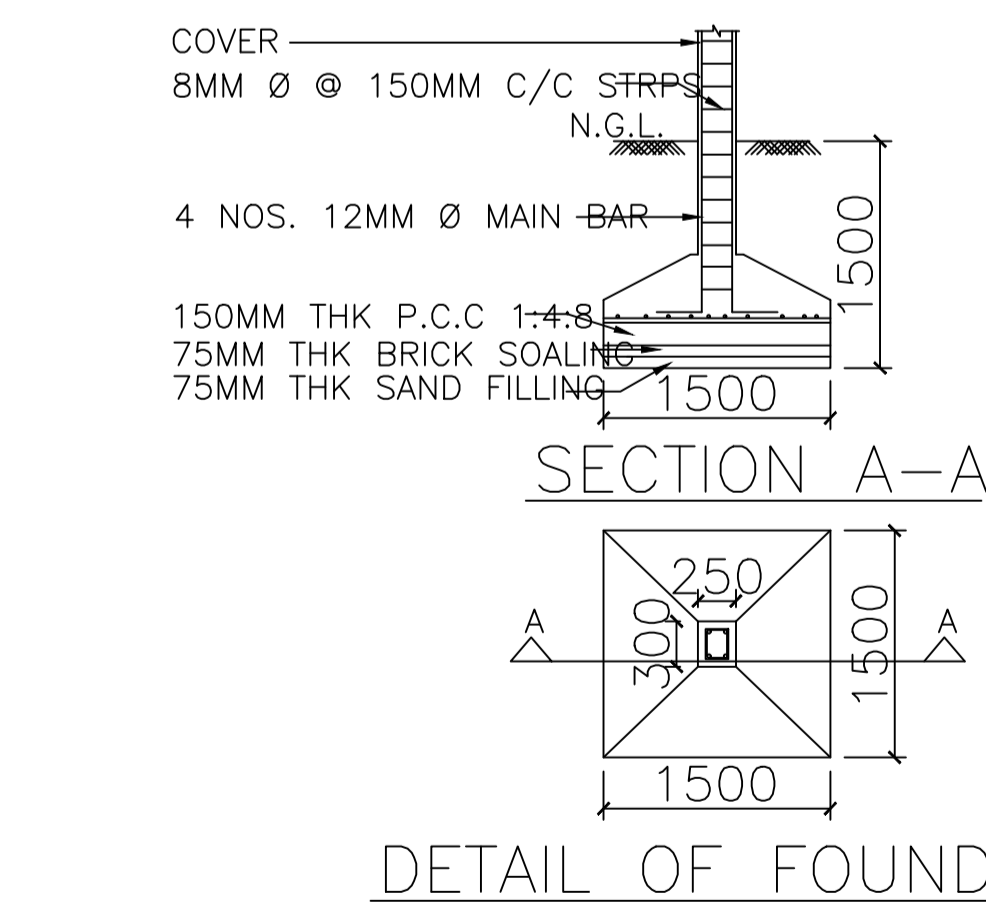

SCHEDULE OF DOOR:

BUILDING NAME	NAME	LENGTH	HEIGHT	NOS
YOTAM TOPPO (A BUILDING)	D1	0.76	2.10	02
YOTAM TOPPO (A BUILDING)	D1	0.91	2.10	08
YOTAM TOPPO (A BUILDING)	D4	1.22	2.10	04
YOTAM TOPPO (A BUILDING)	FD	3.00	2.10	02

SCHEDULE OF WINDOW/VENTILATION:

BUILDING NAME	NAME	LENGTH	HEIGHT	NOS
YOTAM TOPPO (A BUILDING)	V	0.60	1.20	02
YOTAM TOPPO (A BUILDING)	W	1.52	1.20	14

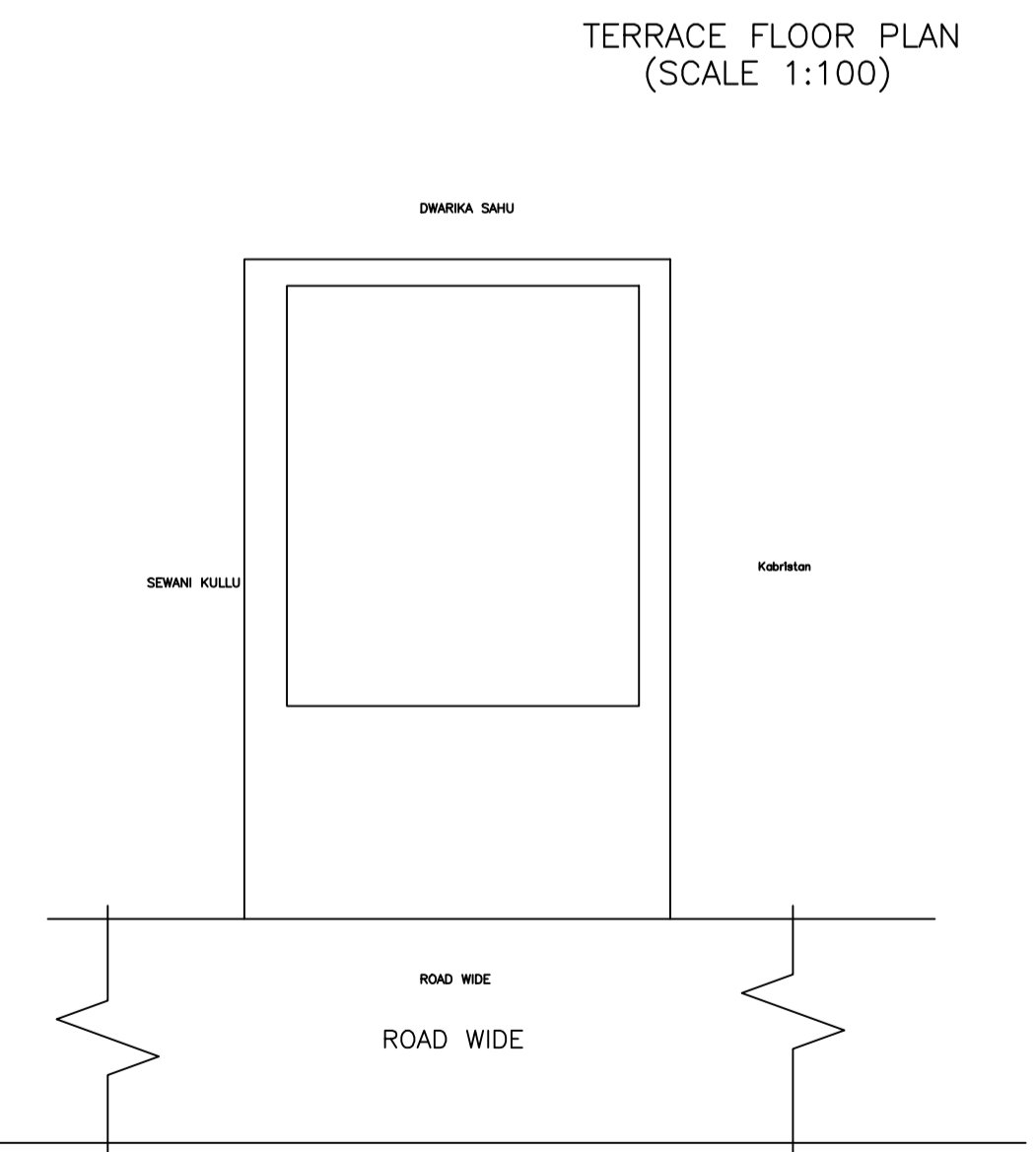
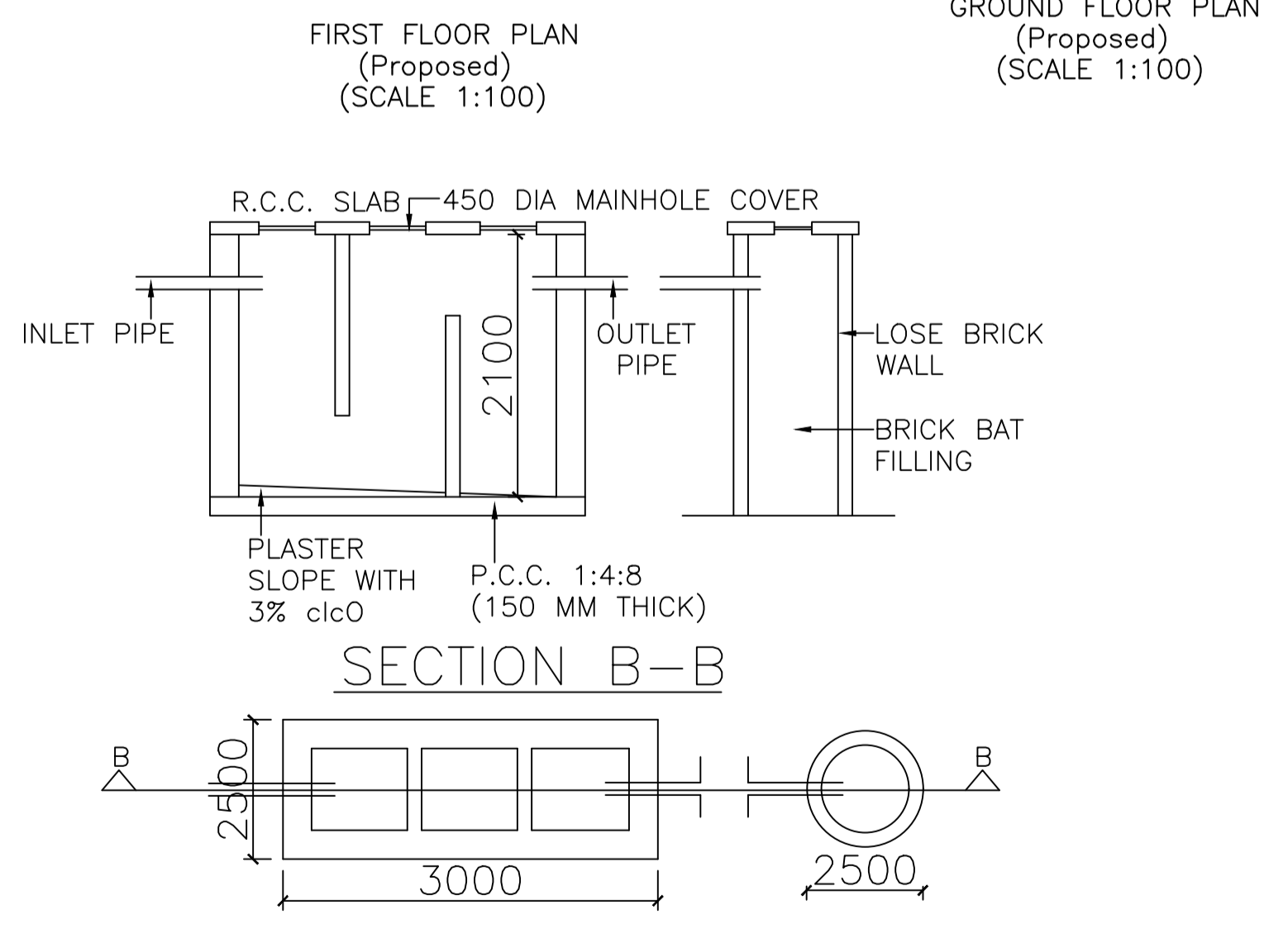

UnitBUA Table for Building :YOTAM TOPPO (A BUILDING)

FLOOR	Name	UnitBUA Type	UnitBUA Area	Carpet Area	No. of Rooms	No. of Tenement
GROUND FLOOR	SPLIT A	FLAT	175.81	175.69	8	1
FIRST FLOOR	SPLIT A	FLAT	0.00	0.00	8	0
Total:	-	-	175.81	175.69	16	1

Structure Detail

COLOR INDEX

PILOT BOUNDARY	Black
ABUTTING ROAD	Green
PROPOSED CONSTRUCTION	Red
COMMON PLOT	Blue
ROAD WIDENING AREA	Yellow
EXISTING (To be retained)	Light Blue
EXISTING (To be demolished)	Light Yellow

LTP NAME AND SIGNATURE	STRUCTURAL ENG'S NAME AND SIGNATURE	BUILDER NAME AND SIGNATURE	DIGITAL SIGNATURE
RAWNIT KUMAR GUNPC/ENG/0004/2019			