

Proposal Basic Information

Proposal File No.	GUNPC/BP/0020/W11/2023
Owner Name	SWAMI NATH SAHU
Khata No	36
Plot No	1496
Village Name	Shanti Nagar
Use	Residential
SubUse	Bungalow/ Dwelling / Non Apartment

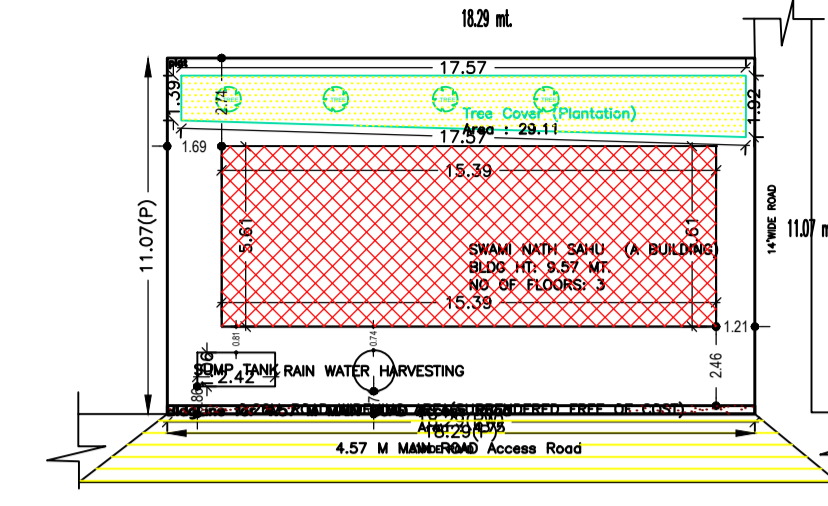
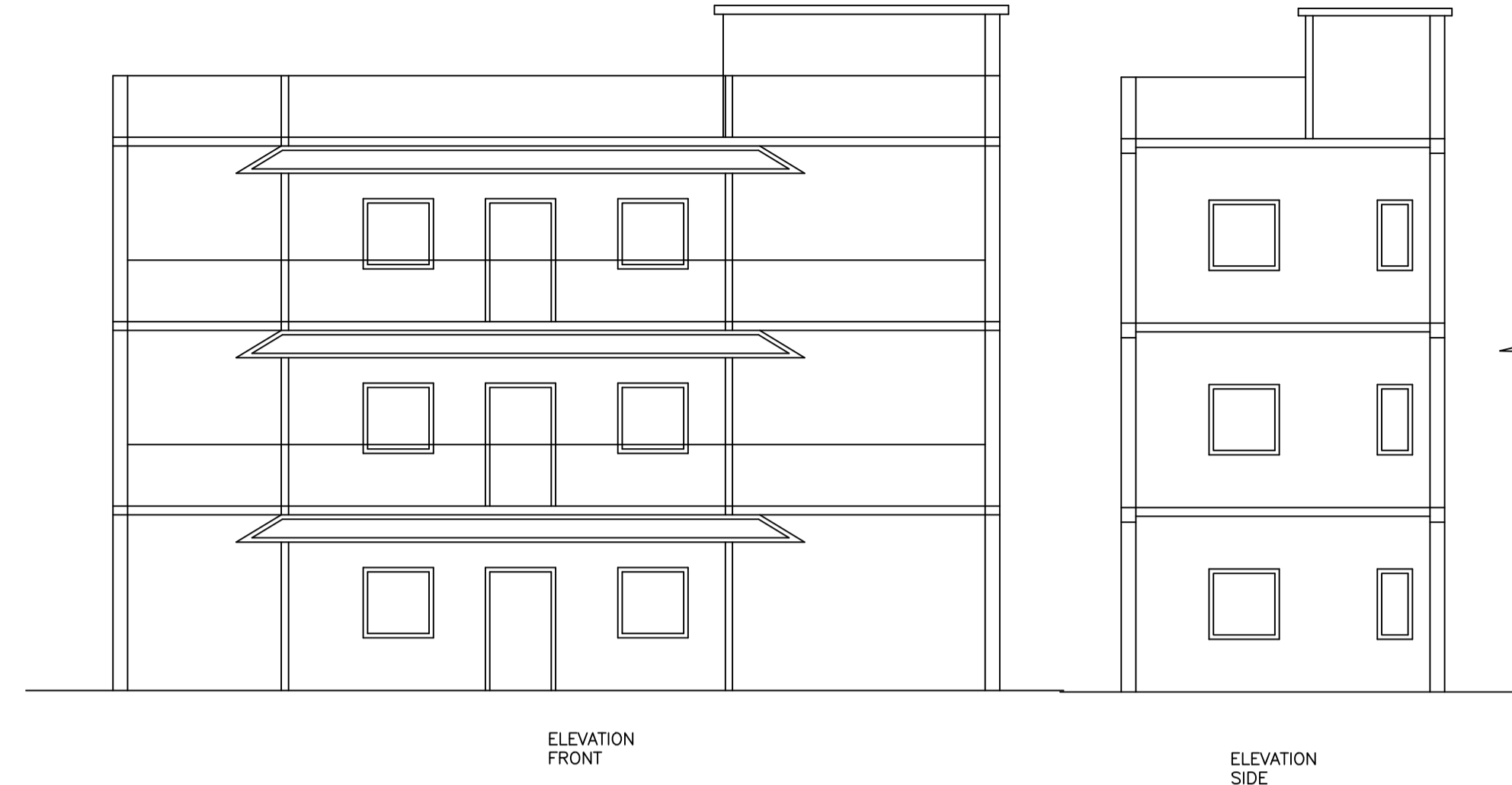

UnitBUA Table for Building :SWAMI NATH SAHU (A BUILDING)

FLOOR	Name	UnitBUA Type	Entity Type	UnitBUA Area	Carpet Area	No. of Rooms	No. of Tenement
GROUND FLOOR PLAN	SPLIT A	FLAT	Existing	198.52	198.42	7	1
FIRST FLOOR PLAN	SPLIT A	FLAT	Existing	0.00	0.00	7	0
SECOND FLOOR PLAN	SPLIT A	FLAT	Proposed	0.00	0.00	7	0
Total:	-	-	-	198.52	198.42	21	1

SCHEDULE OF DOOR:

BUILDING NAME	NAME	LENGTH	HEIGHT	NOS
SWAMI NATH SAHU (A BUILDING)	D1	0.76	2.10	06
SWAMI NATH SAHU (A BUILDING)	D	0.91	2.10	03
SWAMI NATH SAHU (A BUILDING)	D	0.99	2.10	06
SWAMI NATH SAHU (A BUILDING)	D	1.07	2.10	03
SWAMI NATH SAHU (A BUILDING)	D2	1.22	2.10	03

SCHEDULE OF WINDOW/VENTILATION:

BUILDING NAME	NAME	LENGTH	HEIGHT	NOS
SWAMI NATH SAHU (A BUILDING)	V	0.60	1.20	06
SWAMI NATH SAHU (A BUILDING)	W1	0.91	1.20	06
SWAMI NATH SAHU (A BUILDING)	W	1.22	1.20	21

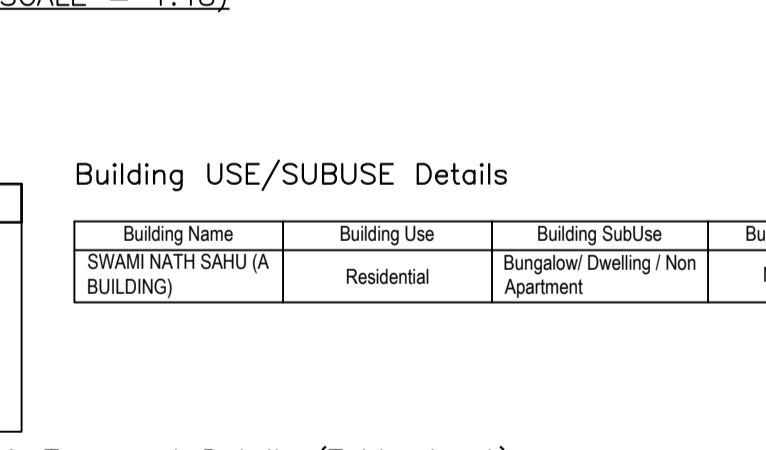
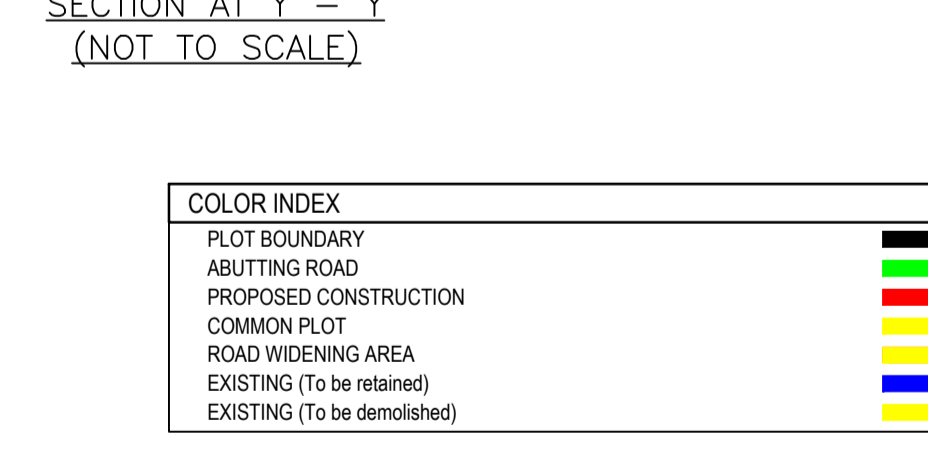
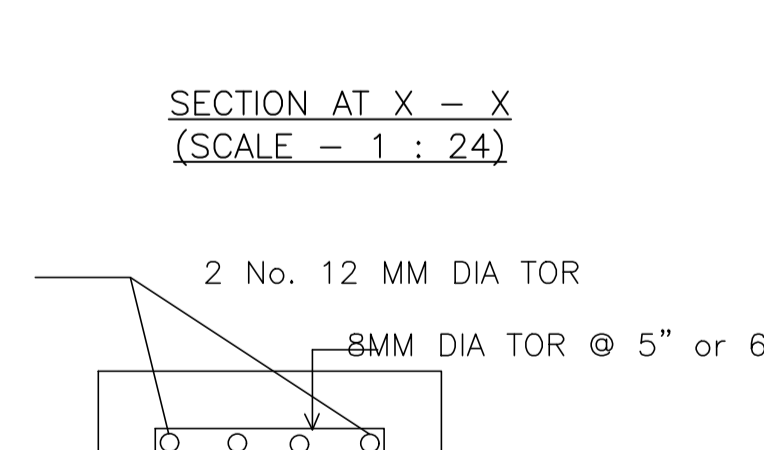
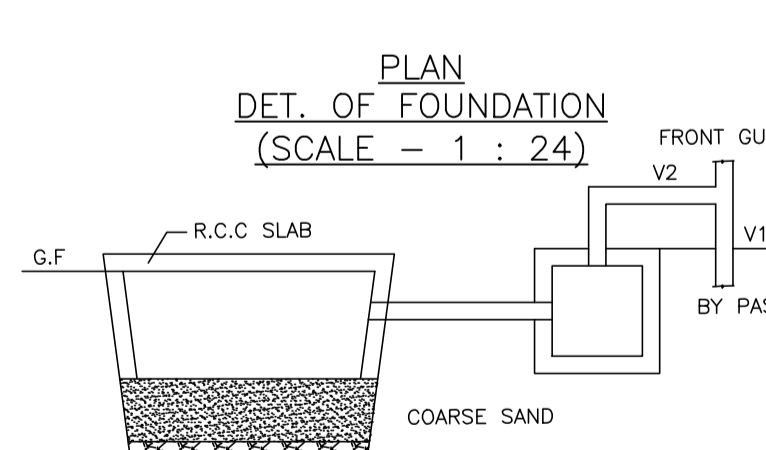
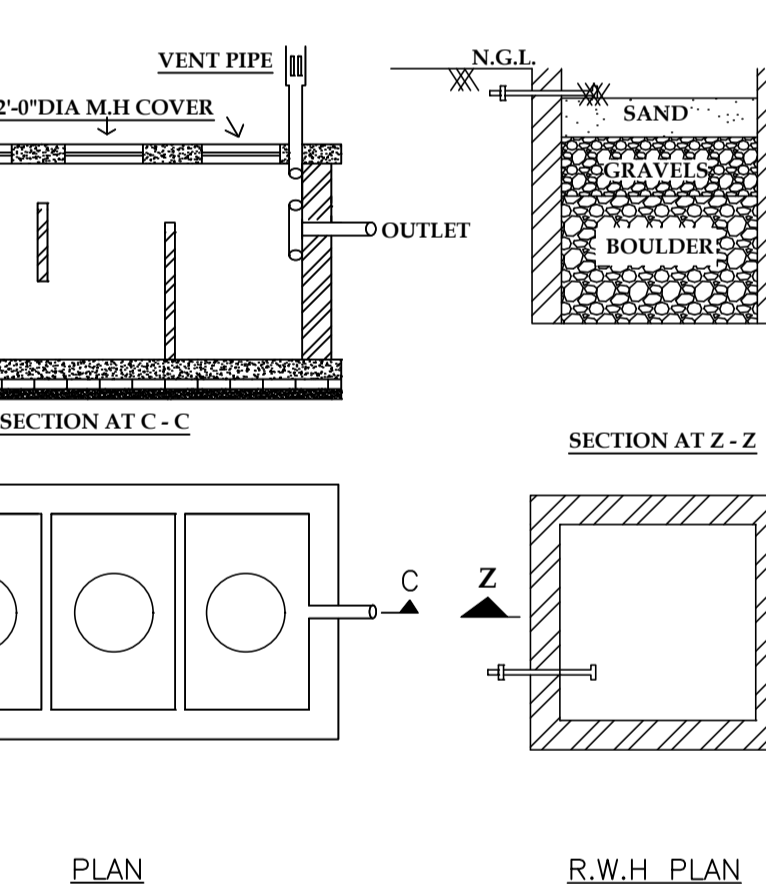
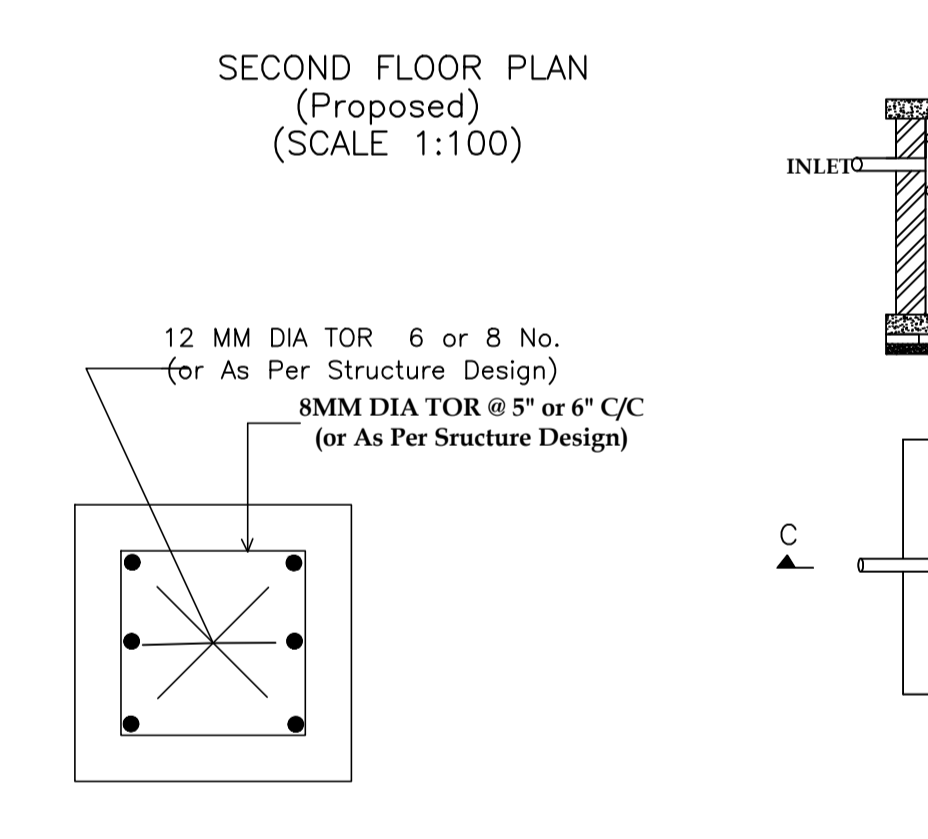
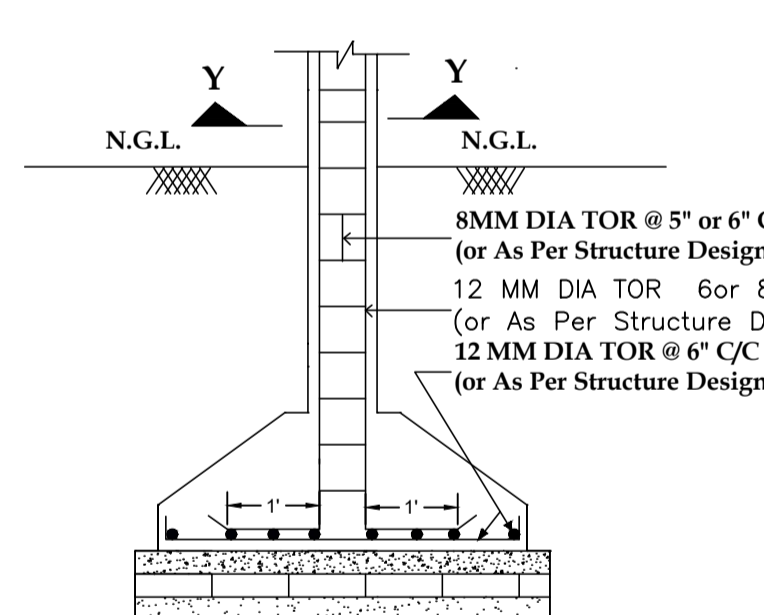
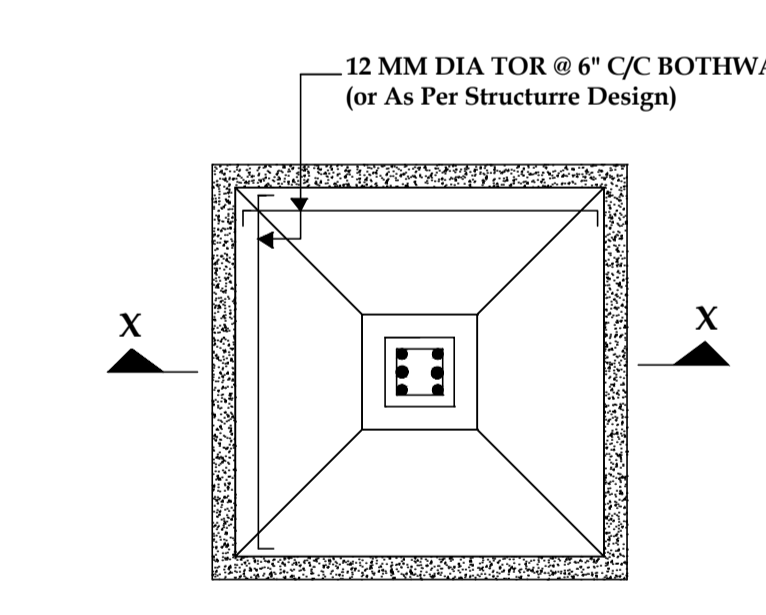
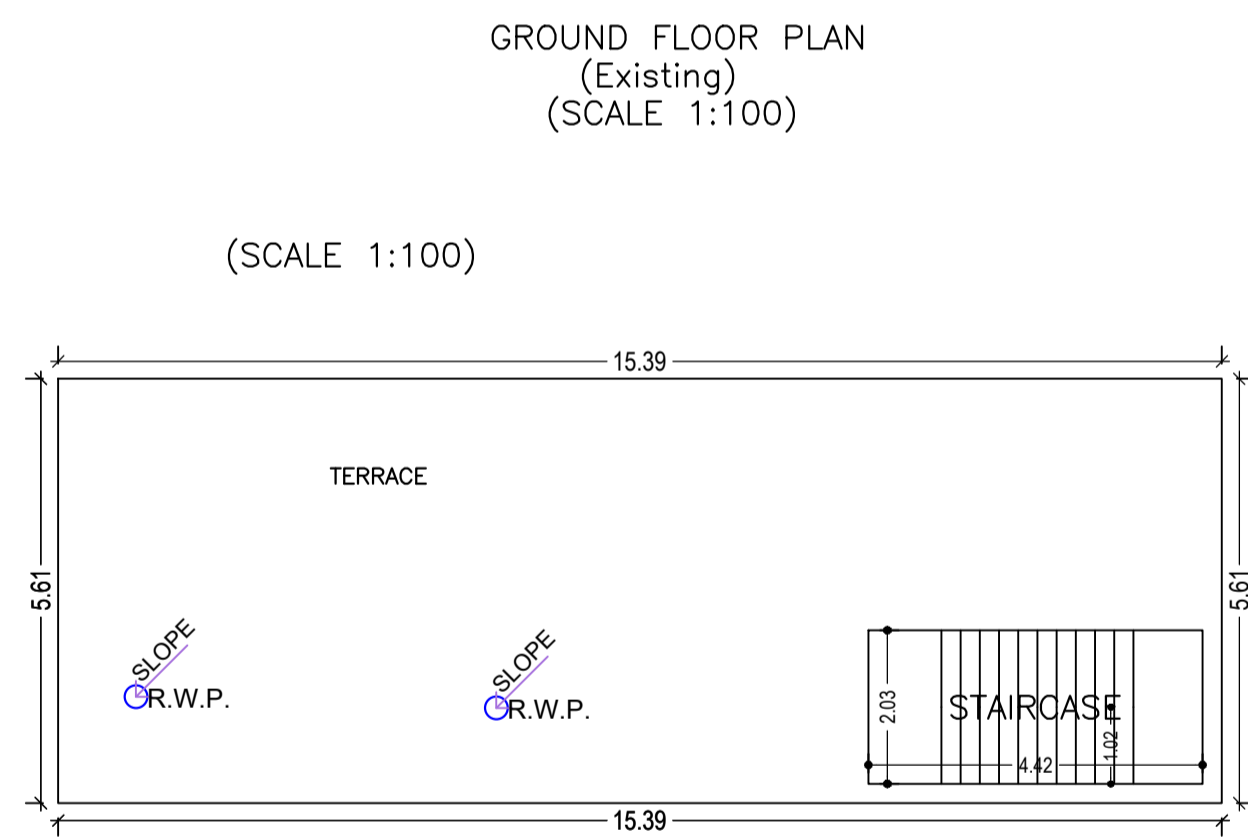
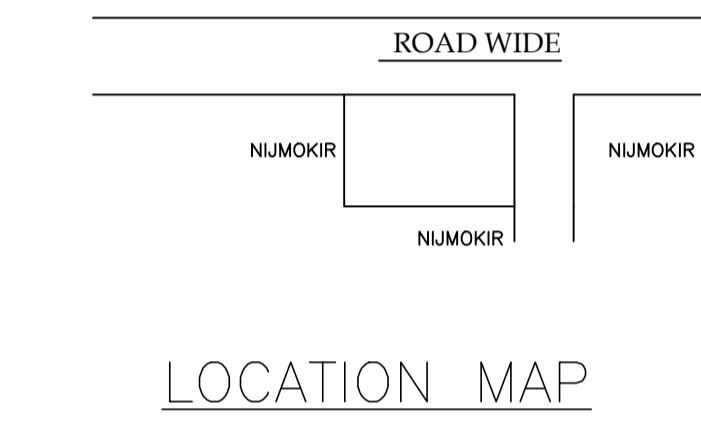
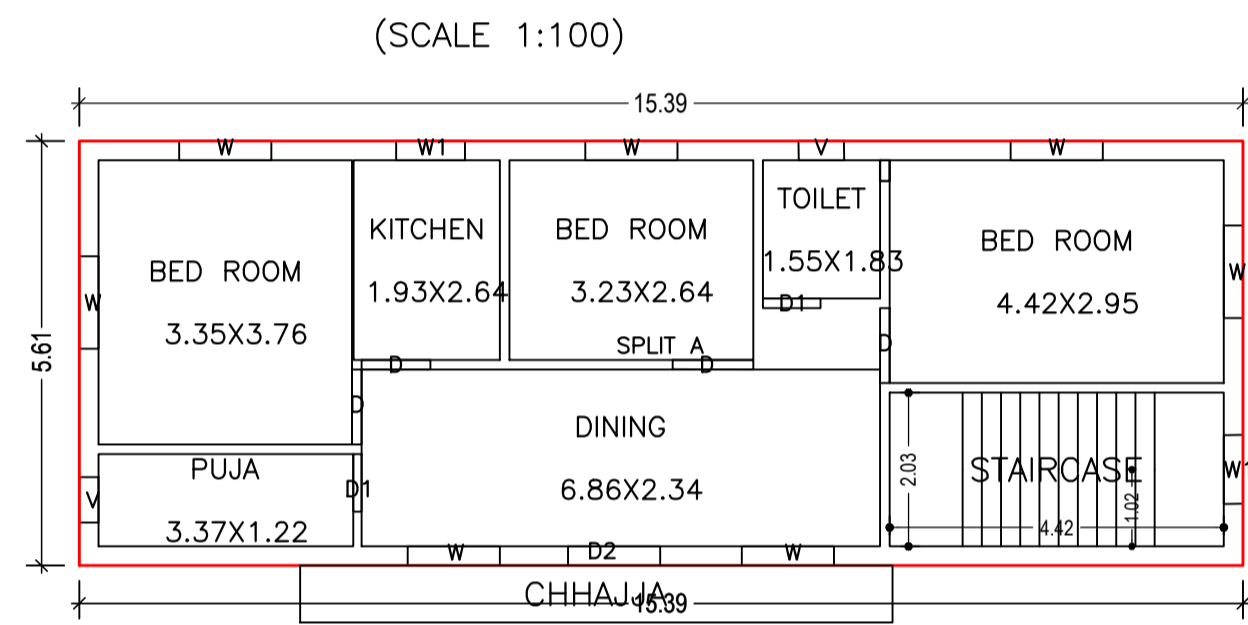
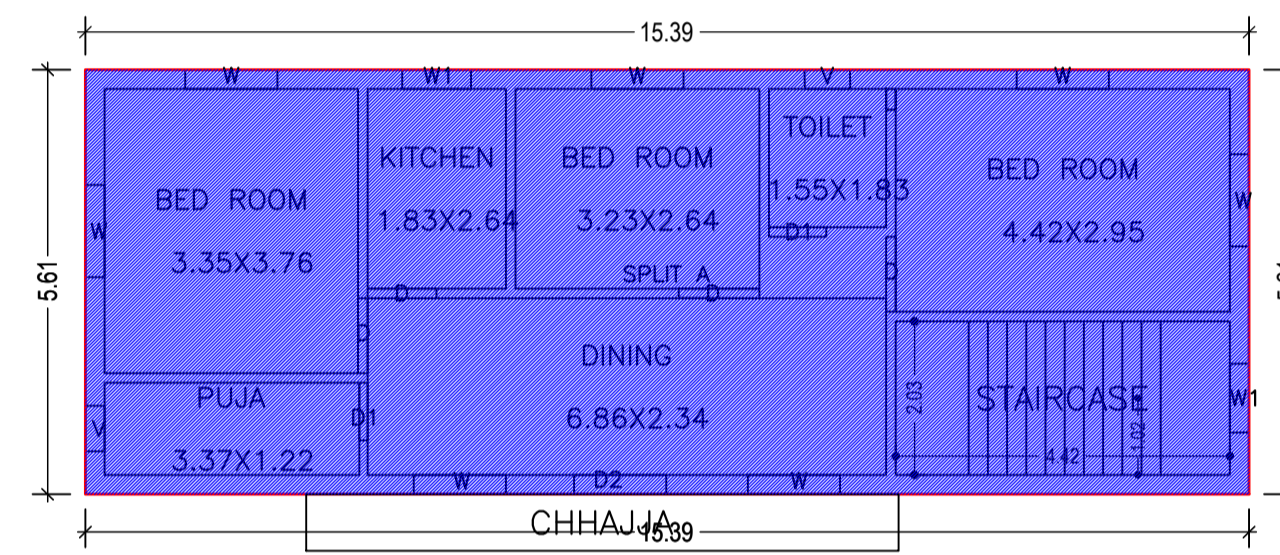
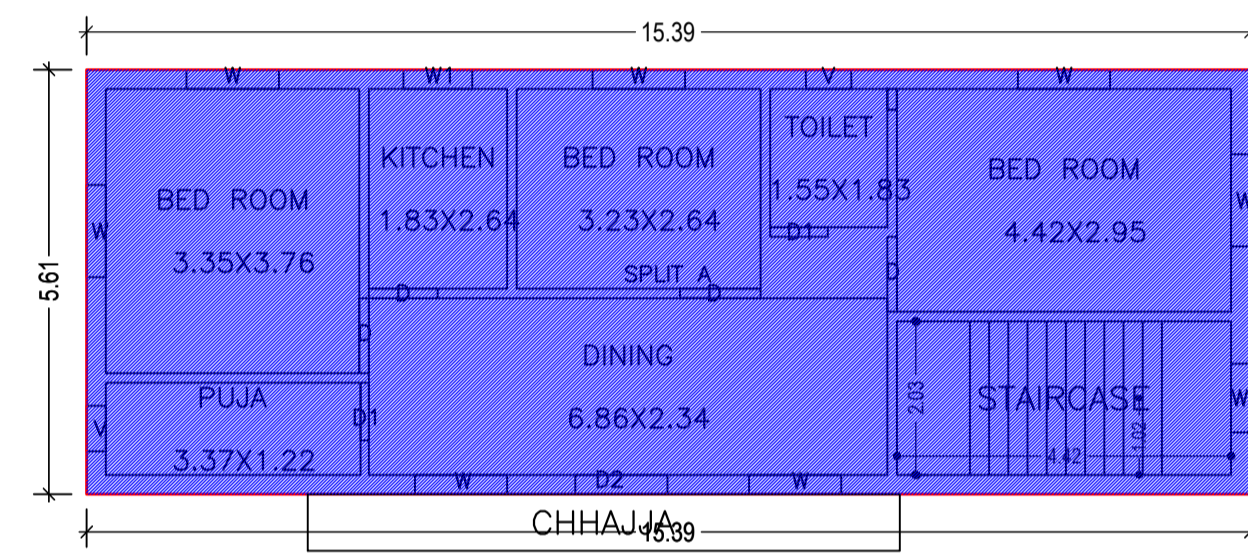

Building :SWAMI NATH SAHU (A BUILDING)

Floor Name	Total Built Up Area (Sq.mt.)	Existing Built Up Area (Sq.mt.)	Proposed Built Up Area (Sq.mt.)	Existing FAR Area (Sq.mt.)	Proposed FAR Area (Sq.mt.)	Total FAR Area (Sq.mt.)	Total Consumed Additional FAR Area (Sq.mt.)	Trmt (No.)
Ground Floor	86.40	86.40	0.00	86.40	0.00	86.40	86.40	01
First Floor	86.40	86.40	0.00	86.40	0.00	86.40	86.40	00
Second Floor	86.40	0.00	86.40	0.00	86.40	86.40	86.40	00
Terrace Floor	0.00	0.00	0.00	0.00	0.00	0.00	0.00	00
Total	259.20	172.80	86.40	172.80	86.40	259.20	259.20	01
Total Number of Same Buildings	1							
Total	259.20	172.80	86.40	172.80	86.40	259.20	259.20	01

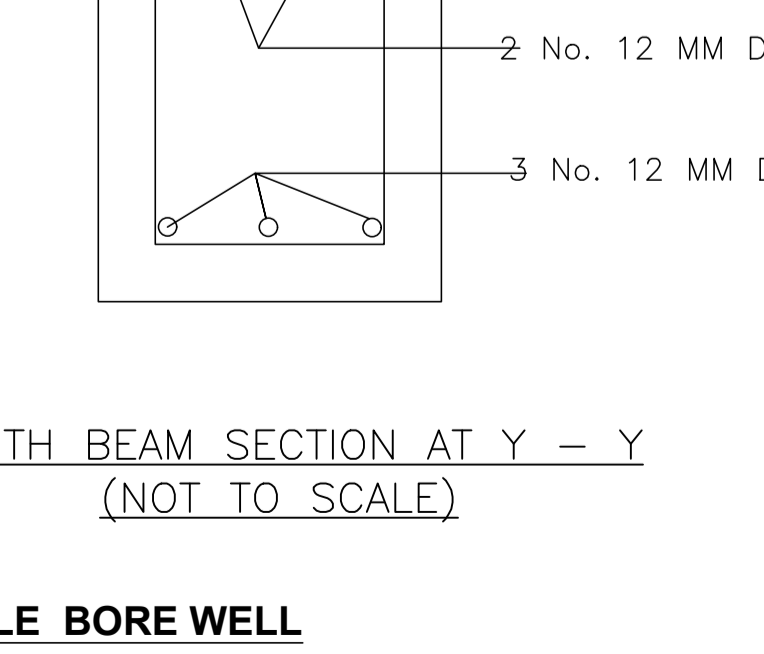
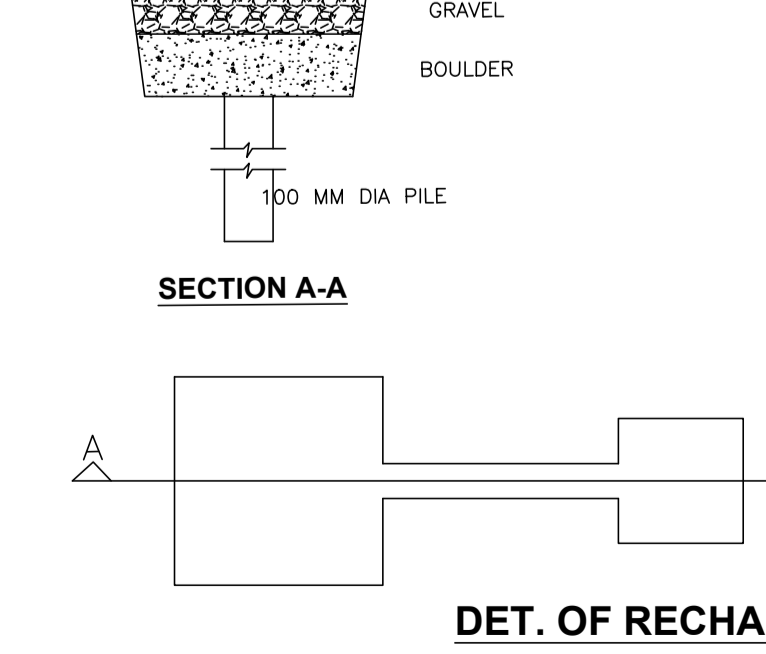

Buildingwise Floor FAR Details

Floor Name	Building Name				Total			
	Proposed Built Up Area (Sq.mt.)	Existing Built Up Area (Sq.mt.)	Proposed FAR Area (Sq.mt.)	Existing FAR Area (Sq.mt.)	Total Proposed Built Up Area (Sq.mt.)	Total Existing Built Up Area (Sq.mt.)	Total FAR Area (Sq.mt.)	Total Existing FAR Area (Sq.mt.)
Ground Floor	0.00	86.40	0.00	86.40	0.00	86.40	0.00	86.40
First Floor	0.00	86.40	0.00	86.40	0.00	86.40	0.00	86.40
Second Floor	86.40	0.00	86.40	0.00	86.40	0.00	86.40	0.00
Terrace Floor	0.00	0.00	0.00	0.00	0.00	0.00	0.00	0.00
Total	86.40	172.80	86.40	172.80	86.40	172.80	86.40	172.80

Building USE/SUBUSE Details

Building Name	Building Use	Building SubUse	Building Structure
SWAMI NATH SAHU (A BUILDING)	Residential	Bungalow Dwelling / Non Apartment	Non-Highrise

FAR & Tenement Details (Table 4c-1)

Building	No. of Same Bldg	Total Built Up Area (Sq.mt.)	Existing Built Up Area (Sq.mt.)	Proposed Built Up Area (Sq.mt.)	Existing FAR Area (Sq.mt.)	Proposed FAR Area (Sq.mt.)	Total FAR Area (Sq.mt.)	Total Consumed Additional FAR Area (Sq.mt.)	Trmt (No.)
SWAMI NATH SAHU (A BUILDING)	1	259.20	172.80	86.40	172.80	86.40	259.20	259.20	01
Grand Total	1	259.20	172.80	86.40	172.80	86.40	259.20	259.20	01

LTP NAME AND SIGNATURE	STRUCTURAL ENG'S NAME AND SIGNATURE	BUILDER NAME AND SIGNATURE	DIGITAL SIGNATURE
RAWNIT KUMAR GUNPC/ENG/0004/2019			