

Proposal Basic Information	
Proposal File No.	GUNPC/BP/0023/W20/2023
Owner Name	SMT. SUMATI KUMARI
Khata No	45
Plot No	964
Village Name	Jawahar Nagar
Use	Residential
SubUse	Bungalow/ Dwelling / Non Apartment

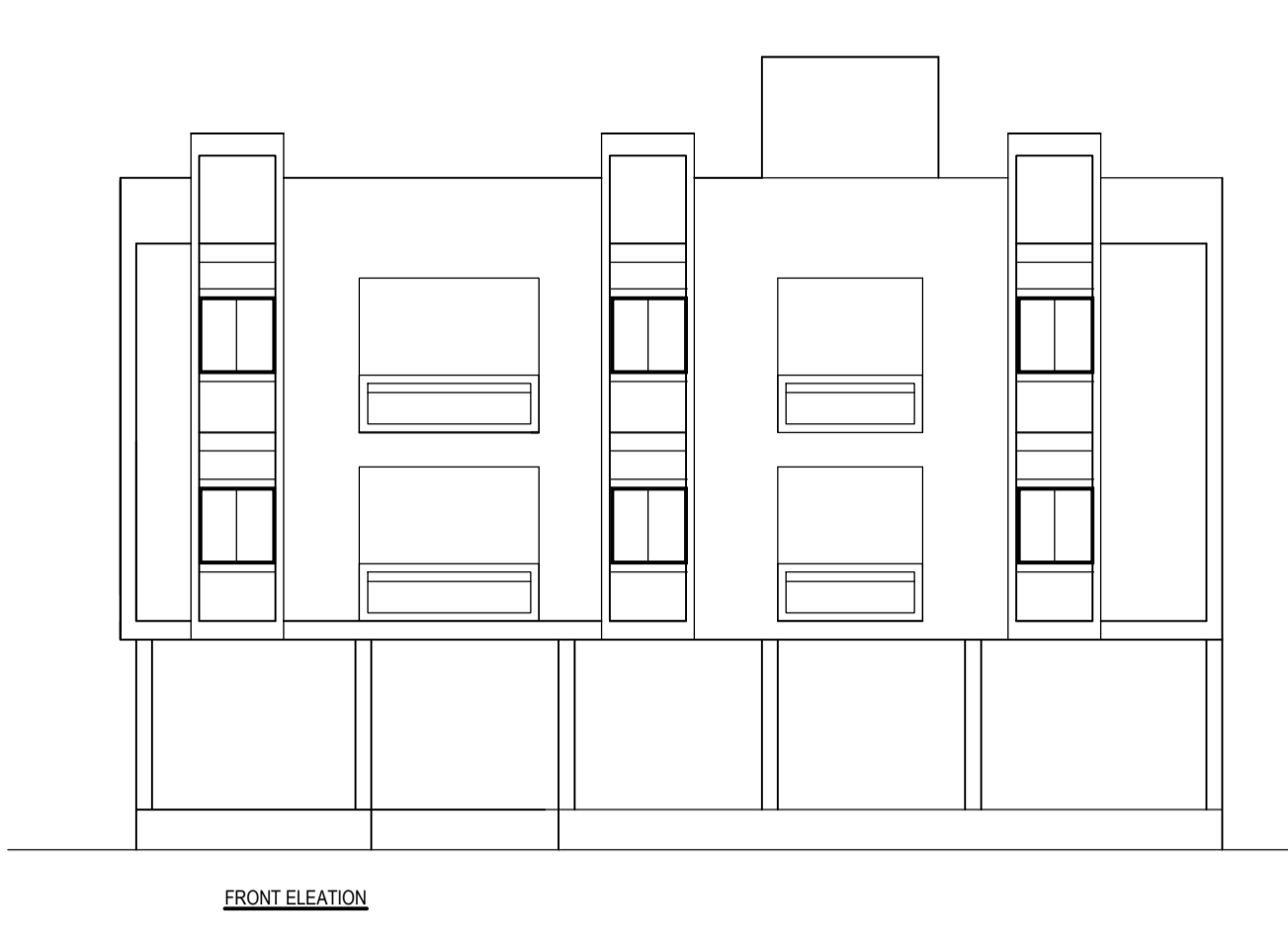

Building :A (RESIDENTIAL BUILDING G2)

Floor Name	Total Built Up Area (Sq.mt.)	Deductions (Area in Sq.mt.)	Proposed FAR Area (Sq.mt.)	Add Area In FAR (Sq.mt.)	Total FAR Area (Sq.mt.)	Total Consumed Additional FAR Area (Sq.mt.)	Trmt (No.)
Ground Floor	192.61	177.30	0.00	15.31	15.31	15.31	01
First Floor	192.61	0.00	192.61	0.00	192.61	192.61	00
Second Floor	192.61	0.00	192.61	0.00	192.61	192.61	01
Terrace Floor	0.00	0.00	0.00	0.00	0.00	0.00	00
Total :	577.83	177.30	385.22	15.31	400.53	400.53	02
Total Number of Same Buildings :	1						
Total :	577.83	177.30	385.22	15.31	400.53	400.53	02

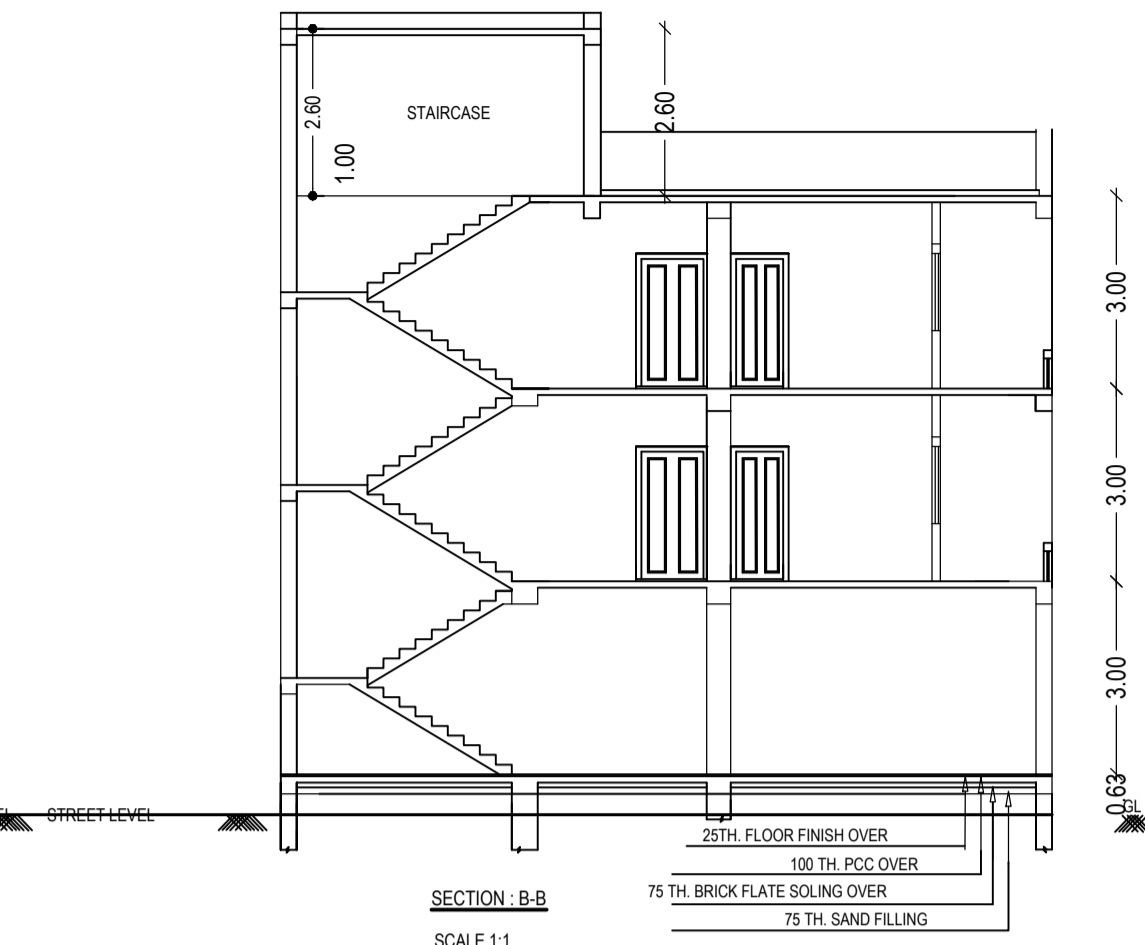
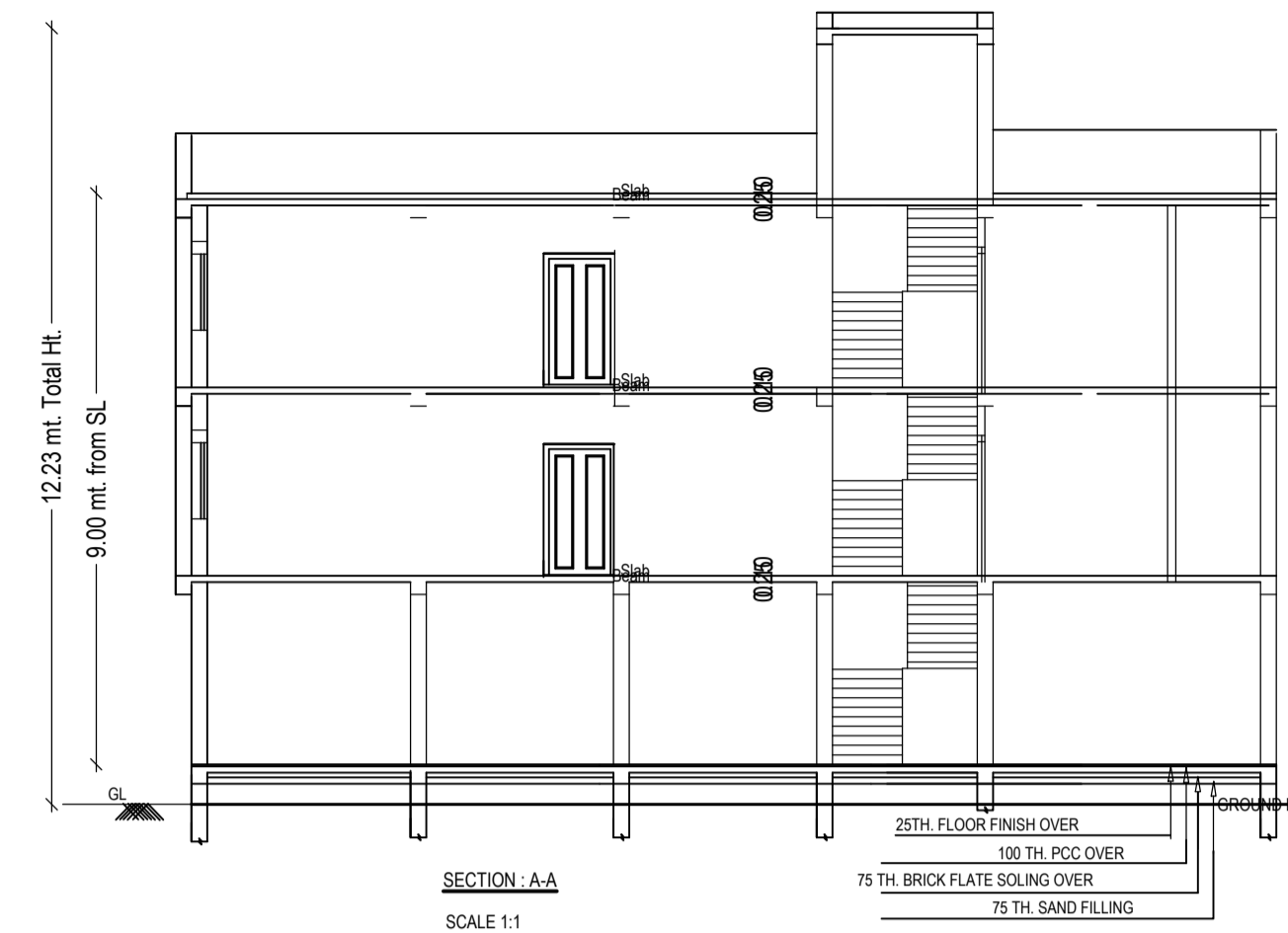
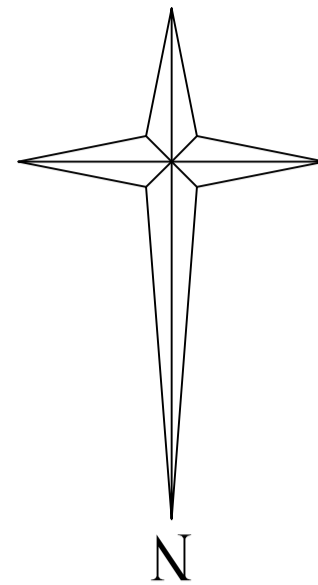
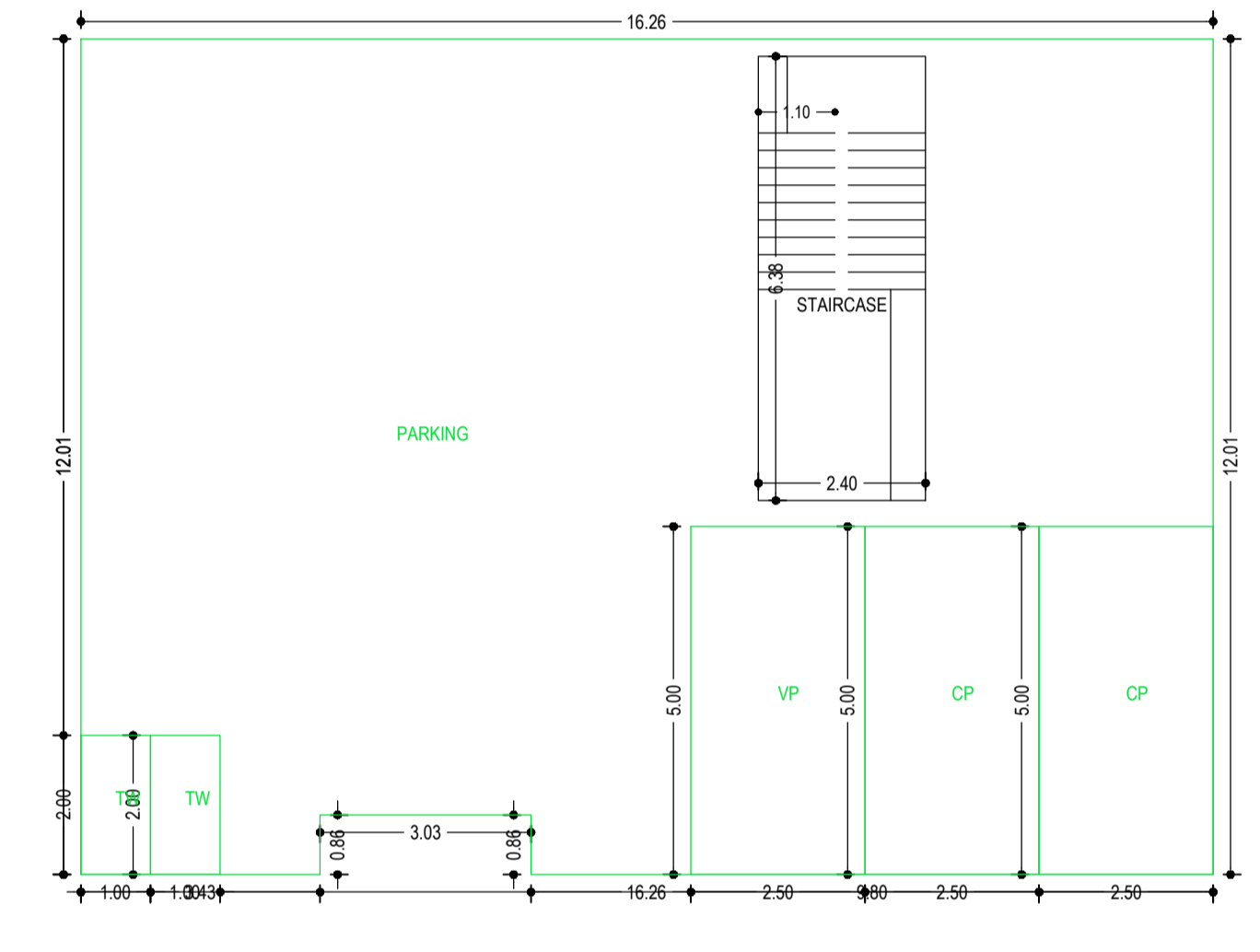

GROUND FLOOR PLAN (SCALE 1:100)

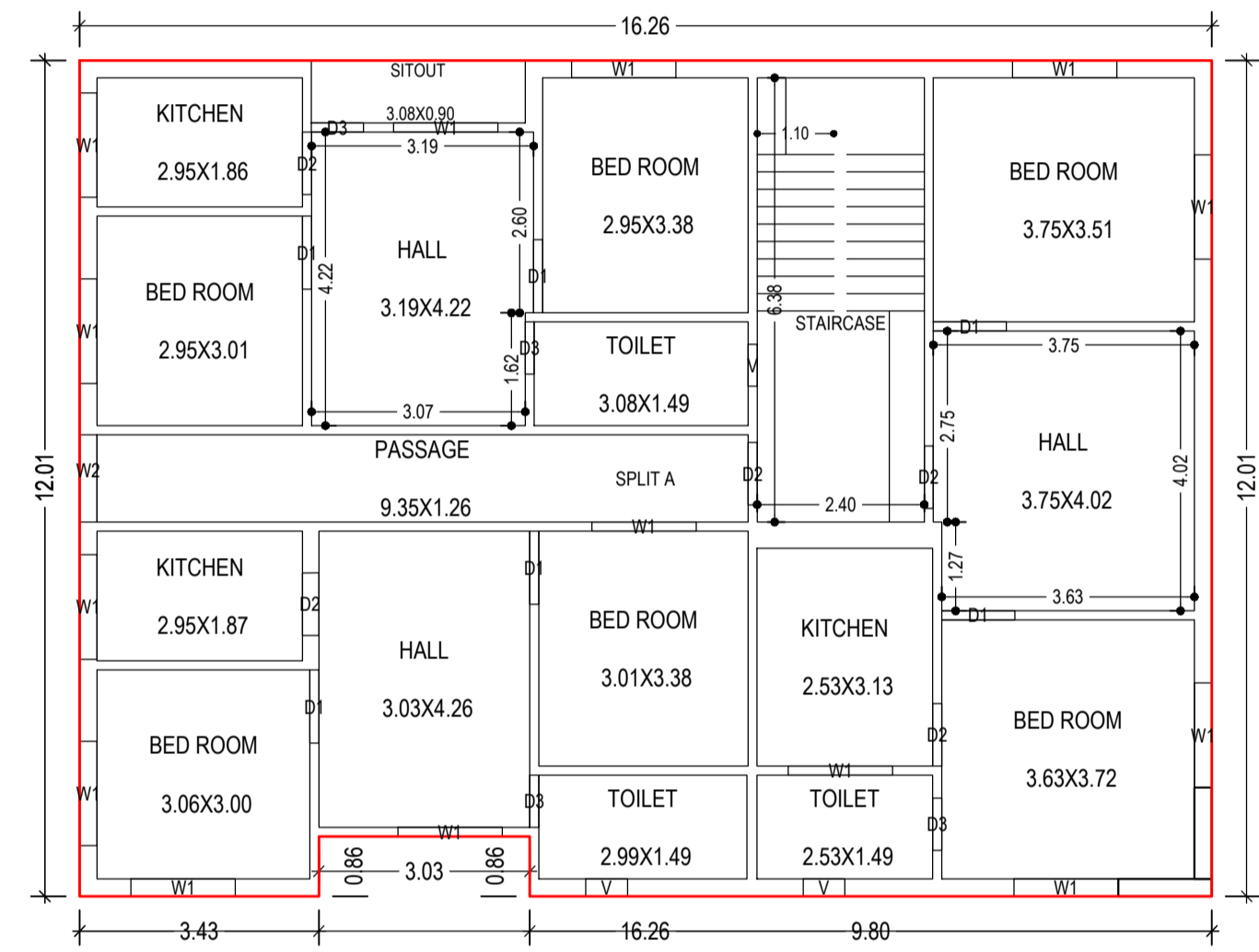

TYPICAL - FIRST & SECOND FLOOR PLAN (Proposed) (SCALE 1:100)

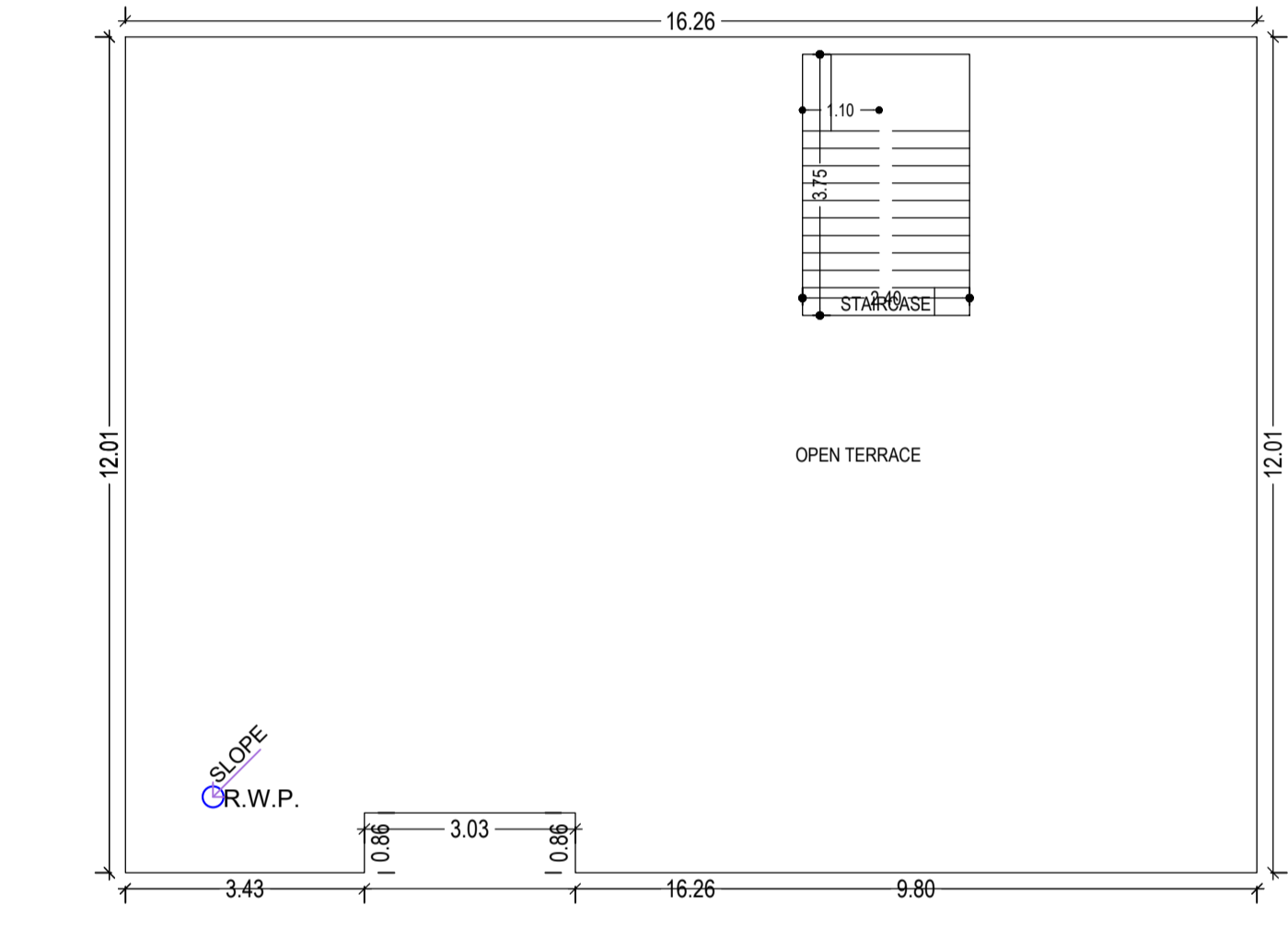

TERRACE FLOOR PLAN (SCALE 1:100)

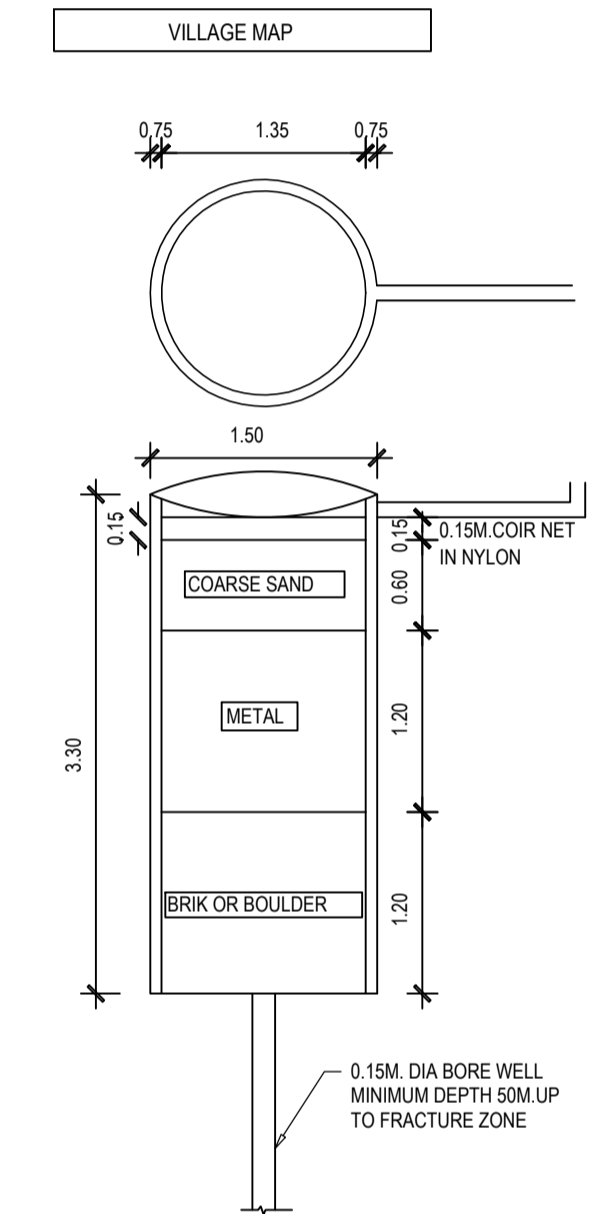

DETAIL OF GROUND WATER RECHARGING PIT WITH SILT TANK

SCHEDULE OF DOOR:

BUILDING NAME	NAME	LENGTH	HEIGHT	NOS
A (RESIDENTIAL BUILDING G2)	D3	0.75	2.10	08
A (RESIDENTIAL BUILDING G2)	D2	0.90	2.10	10
A (RESIDENTIAL BUILDING G2)	D1	1.05	2.10	12

SCHEDULE OF WINDOW/VENTILATION:

BUILDING NAME	NAME	LENGTH	HEIGHT	NOS
A (RESIDENTIAL BUILDING G2)	V	0.60	1.20	06
A (RESIDENTIAL BUILDING G2)	W2	1.26	1.20	02
A (RESIDENTIAL BUILDING G2)	W1	1.50	1.20	28

AREA STATEMENT GUMLA NAGAR PARISHAD		VERSION NO. : 1.0.66
		VERSION DATE: 16/10/2020
PROJECT DETAIL:		
Region: JHARKHAND URBAN LOCAL BODIES	Plot Use: Residential	
District: GUMLA	Plot SubUse: Bungalow/ Dwelling / Non Apartment	
Authority: GUMLA NAGAR PARISHAD	PlotNearby/ReligiousStructure: NA	
Inward No: GUNPC/BP/0023/W20/2023	Plot/SubPlot No: 964	
Application Type: General Proposal	North: -	
Project Type: Building Permission	South: -	
Nature of Development: New	East: -	
Location of Development Area: Old Area	West: -	
AREA DETAILS:		
AREA OF PLOT (Minimum)	(A)	SQ.MT. 344.24
Deduction for NetPlot Area		
Surrender Free of Cost		9.81
Total		9.81
NET AREA OF PLOT(Gross Plot Area - Deduction from Gross Plot area)	(A-Deductions)	334.43
Deduction for Balance Plot Area(from Gross Plot Area)		
Surrender Free of Cost		9.81
Common Plot		29.88
Total		39.68
BALANCE AREA OF PLOT(Net Plot Area - Recreational/Amenity space)	(A-Deductions)	304.56
PLOT AREA FOR COVERAGE(Net Plot Area)	(A-Deductions)	334.43
Plot Area for FAR (Net Plot Area + RoadWidening Area)	(A-Deductions)	344.24
COVERAGE CHECK		
Permissible Coverage area (60.00 %)		200.66
Proposed Coverage Area (57.59 %)		192.61
Total Prop. Coverage Area (57.59 %)		192.61
Balance coverage area (2.41 %)		8.05
FAR CHECK		
Perm. FAR Area (1.800)		619.63
Total Perm. FAR area		619.63
Residential FAR		385.22
Proposed FAR Area		400.53
Total Proposed FAR Area		400.53
Consumed FAR (Factor)		1.16
Balance FAR Area		219.10
BUILT UP AREA CHECK		
Total Proposed BuiltUp Area		577.83
ARCHITECT (Regd)		Dhankeshar Rabi
ENGINEER (Regd)		
SUPERVISOR (Regd)		
OWNER (Regd)		SMT. SUMATI KUMARI
DEVELOPMENT AUTHORITY LOCAL BODY		

Required Parking (Table 7a)

Building Name	Type	SubUse	Area (Sq.mt.)	Units		Car		Visitors Car		TwoWheeler		
				Reqd.	Prop.	Reqd./Unit	Reqd.	Prop.	Reqd./Unit	Reqd.	Prop.	Reqd./Unit
A (RESIDENTIAL BUILDING G2)	Residential	Bungalow/ Dwelling / Non Apartment	> 0	1	2.00	1	2	-	-	-	-	-
			> 0	1	2.00	-	-	1	1	-	-	-
Total :			-	-	-	-	-	2	2	-	1	1

Parking Check (Table 7b)

Vehicle Type	Reqd.		Prop.	
	No.	Area	No.	Area
Car	-	-	2	25.00
Total Car	2	25.00	2	25.00
Visitor's Car Parking	-	-	1	12.50
Total Visitor Parking	1	12.50	1	12.50
TwoWheeler	-	-	2	4.00
Total TwoWheeler	-	-	2	4.00
Other Parking	-	-	-	135.80
Total	-	37.50	-	181.30

FAR & Tenement Details (Table 4c-1)

Building	No. of Same Bldg	Total Built Up Area (Sq.mt.)	Deductions (Area in Sq.mt.)		Proposed FAR Area (Sq.mt.)	Add Area In FAR (Sq.mt.)	Total FAR Area (Sq.mt.)	Total Consumed Additional FAR Area (Sq.mt.)	Trmt (No.)
			Parking	Resi.					
A (RESIDENTIAL BUILDING G2)	1	577.83	177.30	385.22	15.31	400.53	400.53	02	
Grand Total :	1	577.83	177.30	385.22	15.31	400.53	400.53	02	

Buildingwise Floor FAR Details

Floor Name	Building Name		Total	
	Proposed Built Up Area (Sq.mt.)	Proposed FAR Area (Sq.mt.)	Total Proposed Built Up Area (Sq.mt.)	Total FAR Area (Sq.mt.)
Ground Floor	192.61	15.31	192.61	15.31
First Floor	192.61	192.61	192.61	192.61
Second Floor	192.61	192.61	192.61	192.61
Terrace Floor	0.00	0.00	0.00	0.00
Total :	577.83	400.53	577.83	400.53

UnitBUA Table for Building :A (RESIDENTIAL BUILDING G2)

FLOOR	Name	UnitBUA Type	UnitBUA Area	Carpet Area	No. of Rooms	No. of Tenement
TYPICAL -FIRST & SECOND FLOOR PLAN	SPLIT A	FLAT	192.61	191.95	17	2
Total:	-	-	385.22	383.89	34	2

Building USE/SUBUSE Details

Building Name	Building Use	Building SubUse	Building Structure
A (RESIDENTIAL BUILDING G2)	Residential	Bungalow/ Dwelling / Non Apartment	Non-Highrise