

Proposal Basic Information

Proposal File No.	GUNPC/BP/0045/W04/2023
Owner Name	AMRITA LAKRA
Khata No	13
Plot No	289
Village Name	Chetar
Use	Residential
SubUse	Bungalow/ Dwelling / Non Apartment

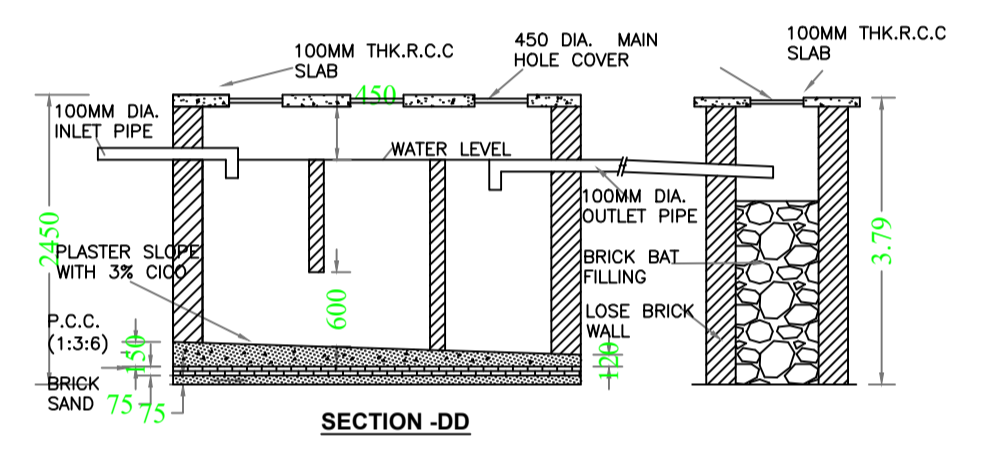
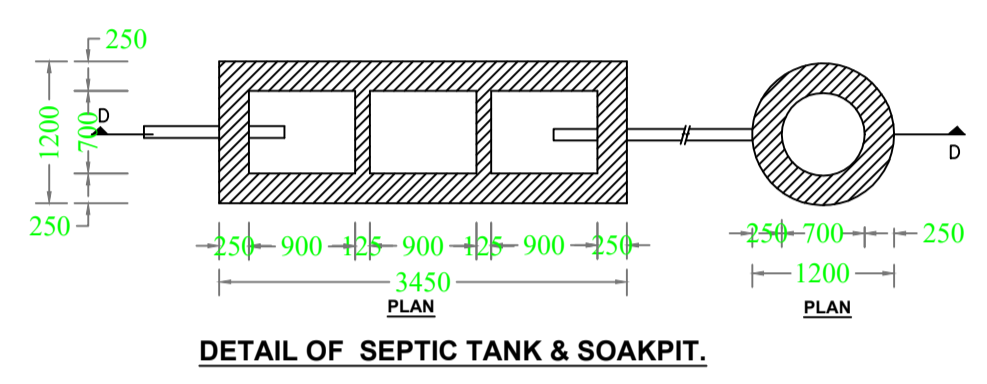
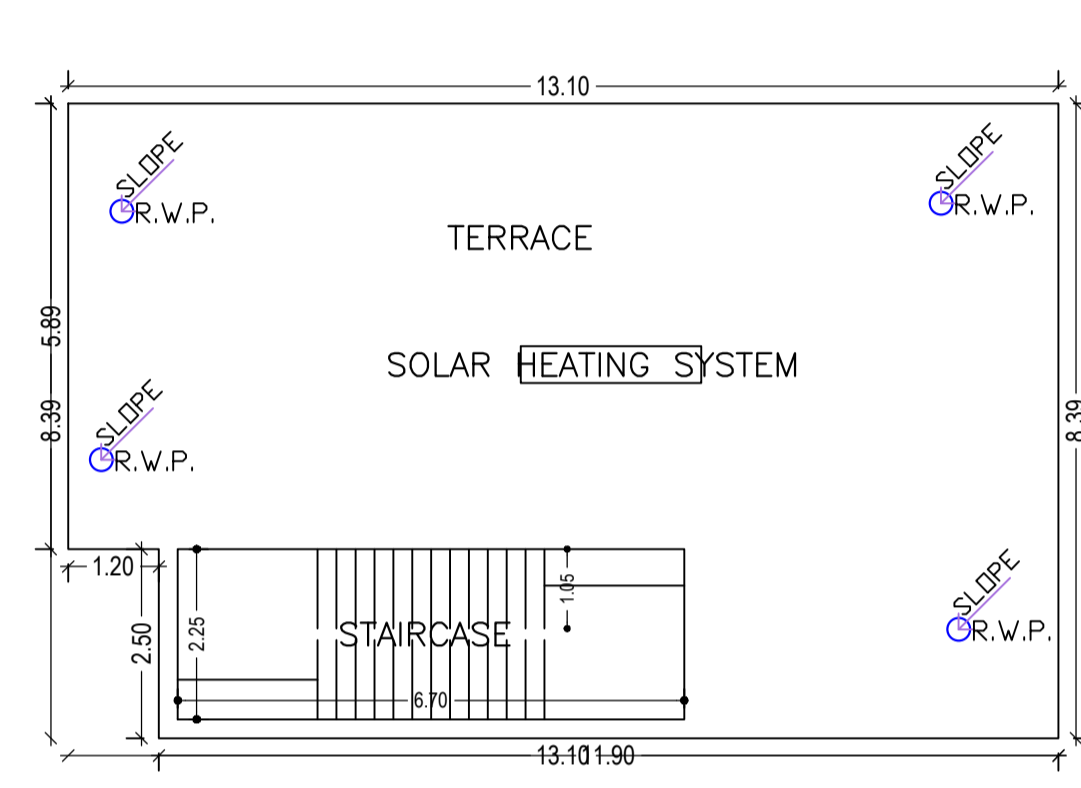
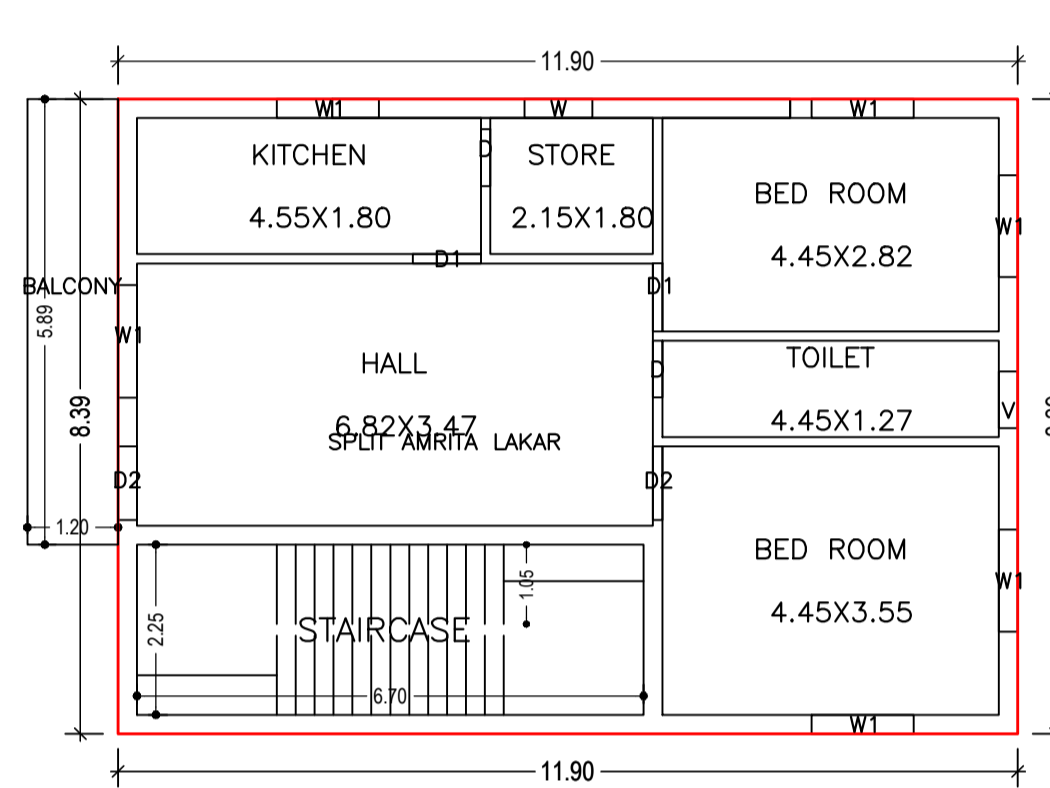
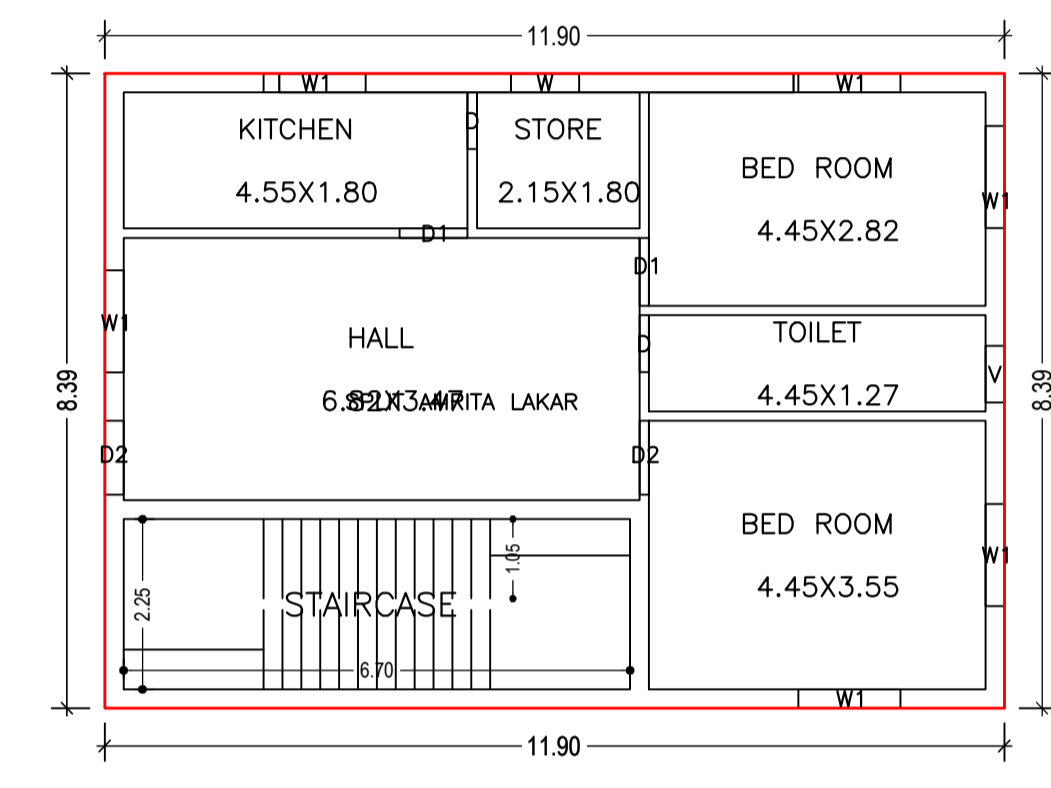
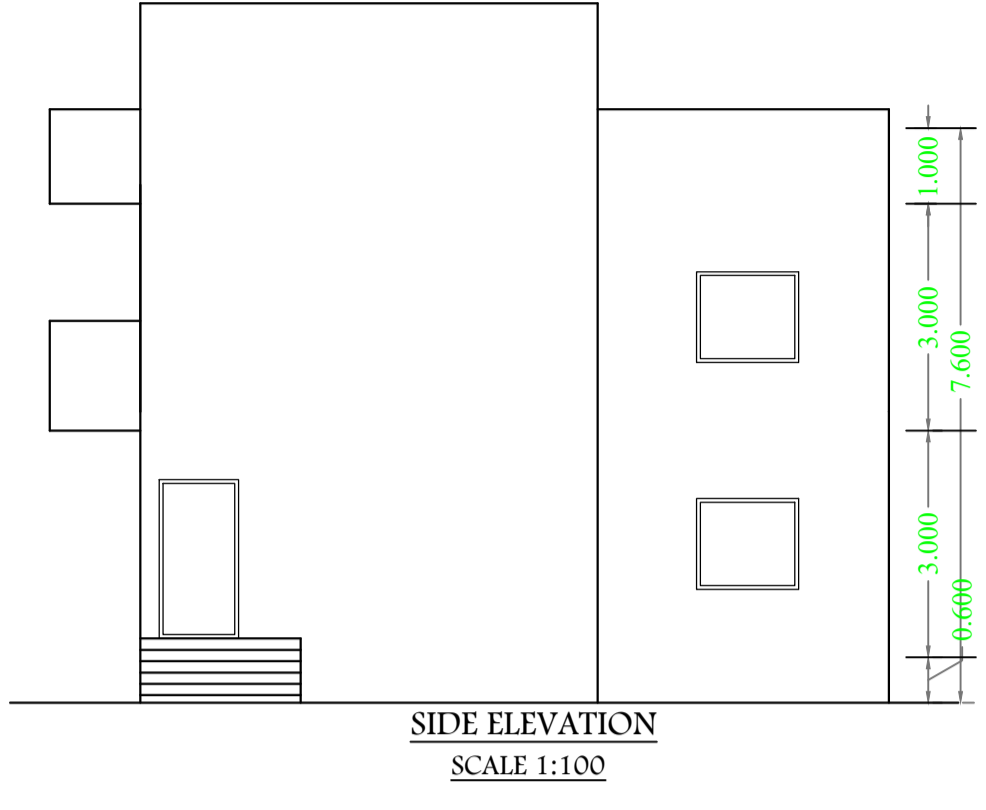
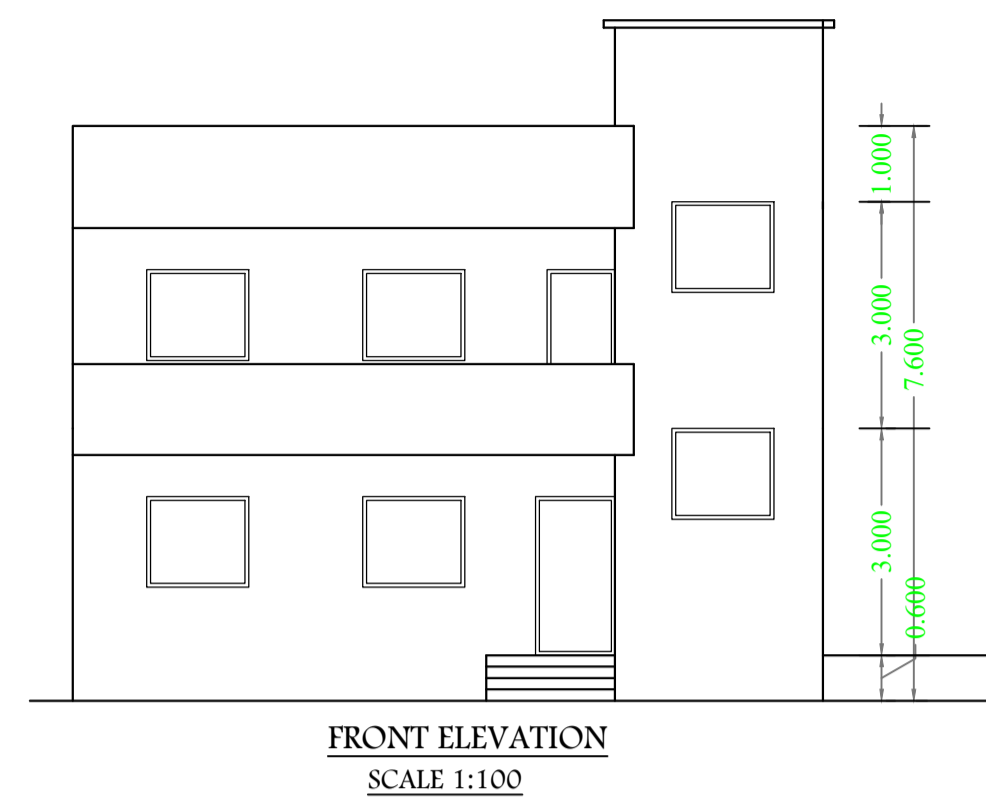
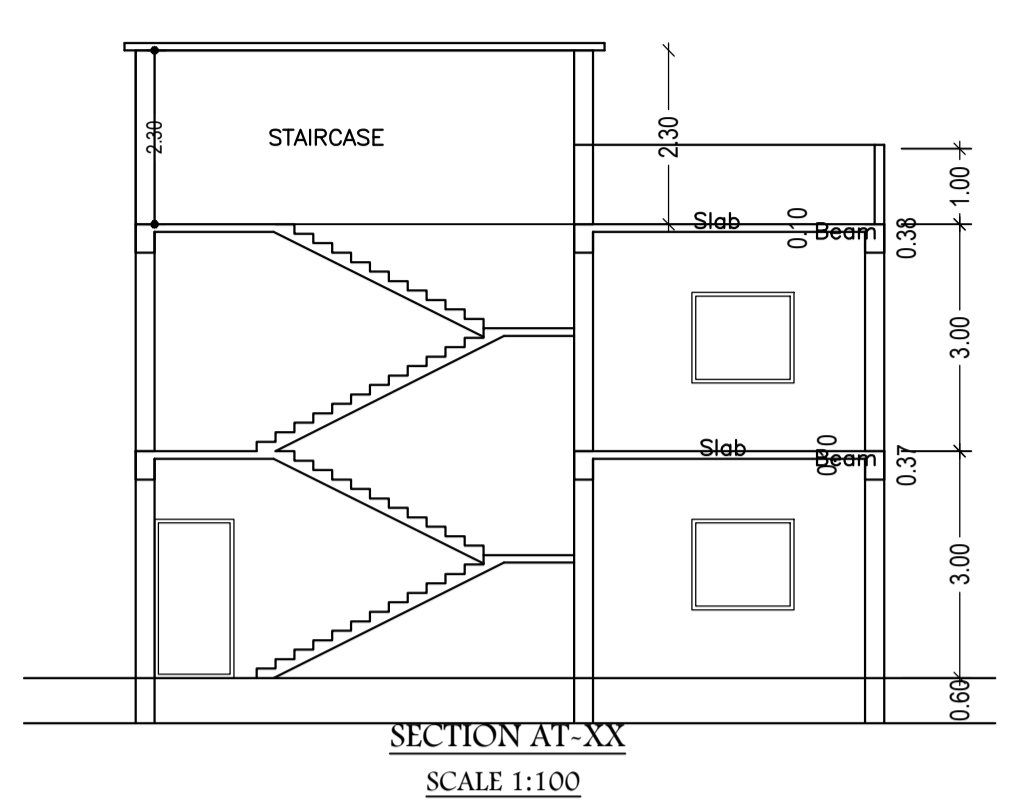
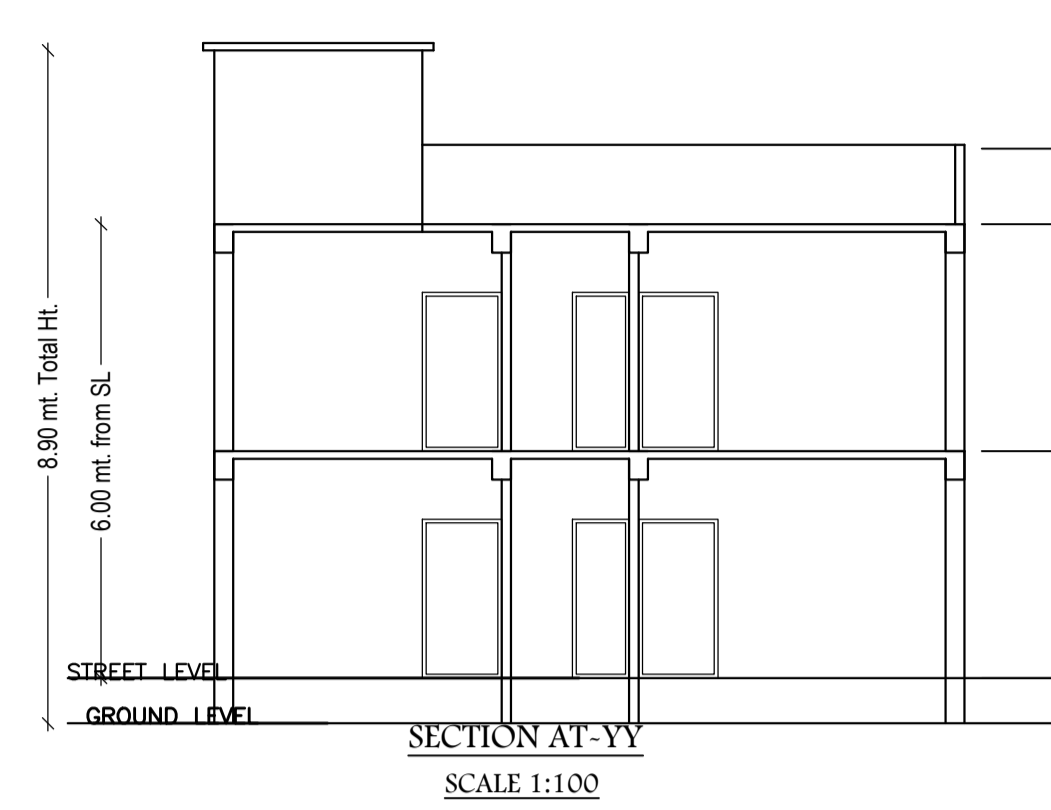

Building :A (AMRITA LAKRA)

Floor Name	Total Built Up Area (Sq.mt.)	Deductions (Area in Sq.mt.)	Proposed FAR Area (Sq.mt.)	Total FAR Area (Sq.mt.)	Total Consumed Additional FAR Area (Sq.mt.)	Tmt (No.)
Ground Floor	99.89	0.00	99.89	99.89	99.89	01
First Floor	106.97	3.54	103.43	103.43	103.43	00
Terrace Floor	0.00	0.00	0.00	0.00	0.00	00
Total :	206.86	3.54	203.32	203.32	203.32	01
Total Number of Same Buildings	1					
Total :	206.86	3.54	203.32	203.32	203.32	01

AREA STATEMENT GUMLA NAGAR PARISHAD		VERSION NO. : 1.0.66
PROJECT DETAIL:		VERSION DATE: 16/10/2020
Region - JHARKHAND URBAN LOCAL BODIES	Plot Use: Residential	
District - GUMLA	Plot SubUse: Bungalow/ Dwelling / Non Apartment	
Authority: GUMLA NAGAR PARISHAD	PlotNearbyReligiousStructure: NA	
Inward_No: GUNPC/BP/0045/W04/2023	Plot/SubPlot No: 289	
Application Type: General Proposal	North: -	
Project Type: Building Permission	South: -	
Nature of Development: New	East: -	
Location of Development Area: Old Area	West: -	
AREA DETAILS:		SQ.MT.
AREA OF PLOT (Minimum)	(A)	376.35
NET AREA OF PLOT(Gross Plot Area - Deduction from Gross Plot area)	(A-Deductions)	376.35
Deduction for Balance Plot Area(from Gross Plot Area)		
Common Plot		32.20
Total		32.20
BALANCE AREA OF PLOT(Net Plot Area - Recreational/Amenity space)	(A-Deductions)	344.15
PLOT AREA FOR COVERAGE(Net Plot Area)	(A-Deductions)	376.35
Plot Area for FAR (Net Plot Area + RoadWidening Area)	(A-Deductions)	376.35
COVERAGE CHECK		
Permissible Coverage area (60.00 %)		225.81
Proposed Coverage Area (26.54 %)		99.89
Total Prop. Coverage Area (26.54 %)		99.89
Balance coverage area (33.46 %)		125.92
FAR CHECK		
Perm. FAR Area (1.500)		564.53
Total Perm. FAR area		564.53
Residential FAR		203.32
Proposed FAR Area		203.32
Total Proposed FAR Area		203.32
Consumed FAR (Factor)		0.54
Balance FAR Area		361.21
BUILT UP AREA CHECK		
Total Proposed BuiltUp Area		206.86
ARCHITECT (Regd)		
DEEPAK DIWAN		
ENGINEER (Regd)		
SUPERVISOR (Regd)		
OWNER (Regd)		
AMRITA LAKRA		
DEVELOPMENT AUTHORITY		LOCAL BODY

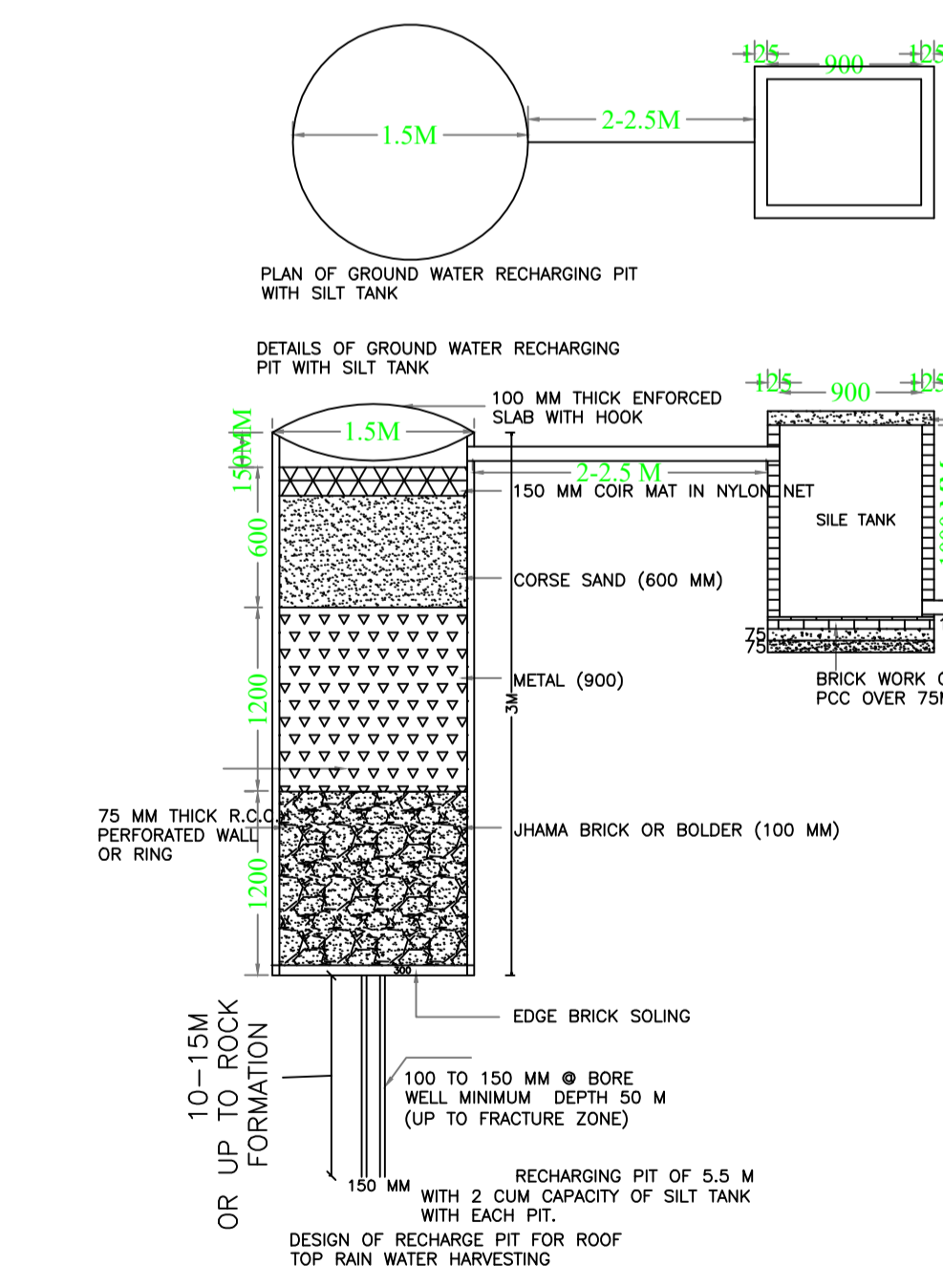
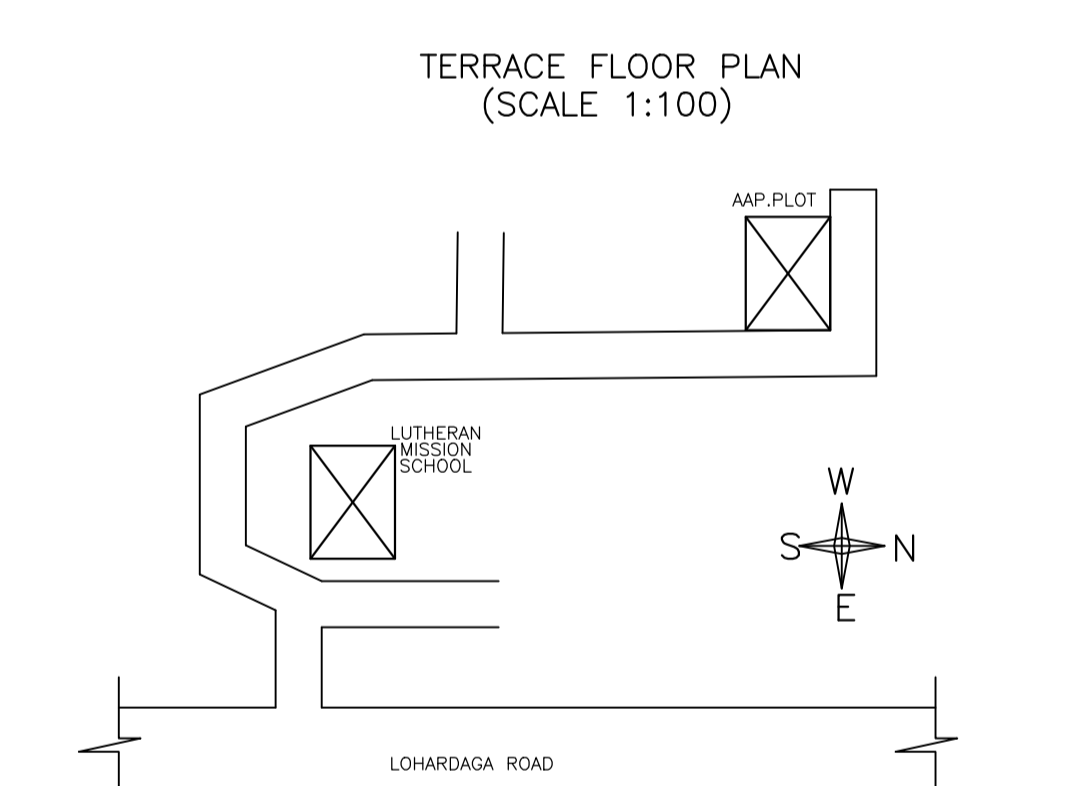
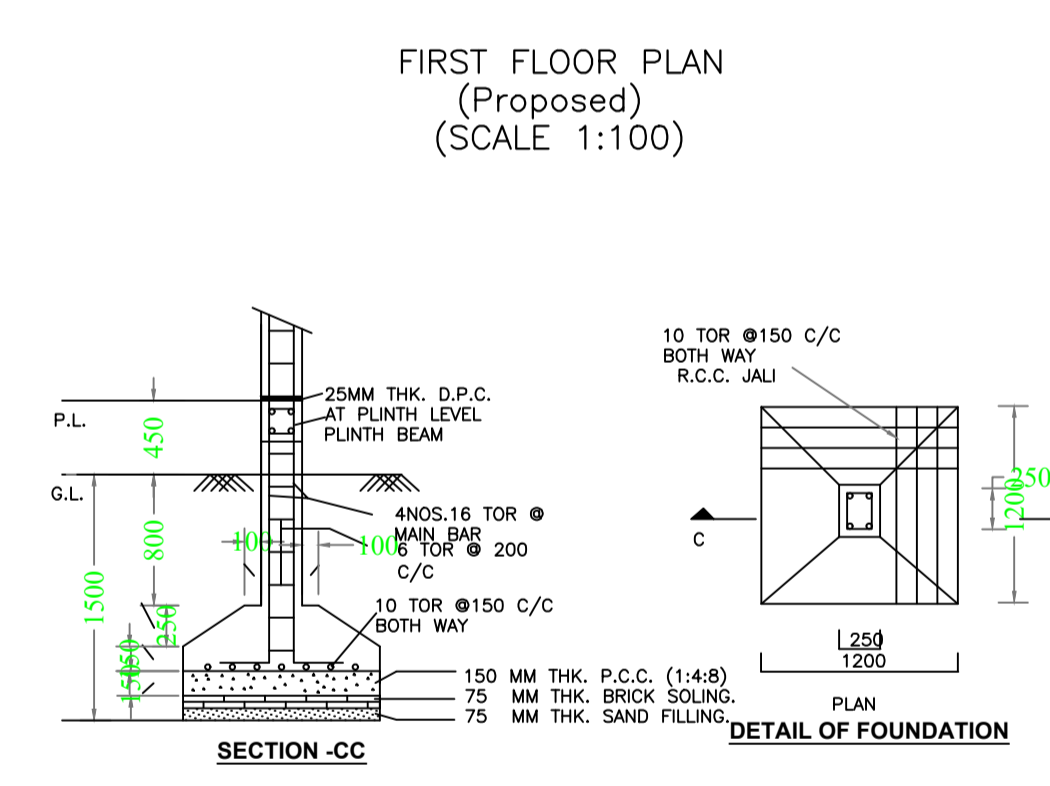
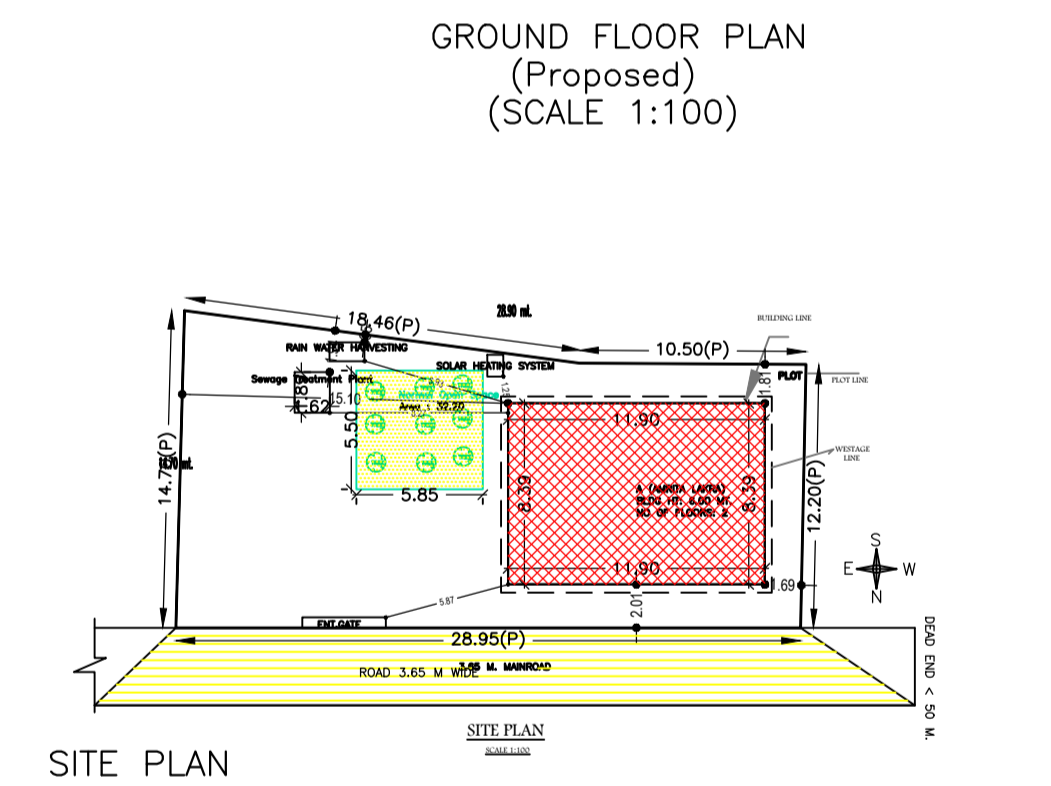

COLOR INDEX

PLOT BOUNDARY	Black
ABUTTING ROAD	Green
PROPOSED CONSTRUCTION	Red
COMMON PLOT	Yellow
ROAD WIDENING AREA	Orange
EXISTING (To be retained)	Blue
EXISTING (To be demolished)	Light Blue

FAR & Tenement Details (Table 4c-1)

Building	No. of Same Bldg	Total Built Up Area (Sq.mt.)	Deductions (Area in Sq.mt.)	Proposed FAR Area (Sq.mt.)	Total FAR Area (Sq.mt.)	Total Consumed Additional FAR Area (Sq.mt.)	Tmt (No.)
A (AMRITA LAKRA)	1	206.86	3.54	203.32	203.32	203.32	01
Grand Total :	1	206.86	3.54	203.32	203.32	203.32	01

UnitBUA Table for Building :A (AMRITA LAKRA)

FLOOR	Name	UnitBUA Type	UnitBUA Area	Carpet Area	No. of Rooms	No. of Tenement
GROUND FLOOR PLAN	SPLIT AMRITA LAKRA	FLAT	206.86	196.57	6	1
FIRST FLOOR PLAN	SPLIT AMRITA LAKRA	FLAT	0.00	0.00	6	0
Total:	-	-	206.86	196.57	12	1

SCHEDULE OF DOOR:

BUILDING NAME	NAME	LENGTH	HEIGHT	NOS
A (AMRITA LAKRA)	D	0.75	2.10	04
A (AMRITA LAKRA)	D1	0.90	2.10	04
A (AMRITA LAKRA)	D2	0.98	2.10	04

SCHEDULE OF WINDOW/VENTILATION:

BUILDING NAME	NAME	LENGTH	HEIGHT	NOS
A (AMRITA LAKRA)	V	0.75	0.60	02
A (AMRITA LAKRA)	W	0.90	1.20	02
A (AMRITA LAKRA)	W1	1.35	1.20	11
A (AMRITA LAKRA)	W1	1.49	1.20	01

Balcony Calculations Table

FLOOR	SIZE	AREA	TOTAL AREA
FIRST FLOOR PLAN	1.20 X 5.90 X 1 X 1	7.07	7.07
Total	-	-	7.07

Buildingwise Floor FAR Details

Floor Name	Building Name A (AMRITA LAKRA)		Total	
	Proposed Built Up Area (Sq.mt.)	Proposed FAR Area (Sq.mt.)	Total Proposed Built Up Area (Sq.mt.)	Total FAR Area (Sq.mt.)
Ground Floor	99.89	99.89	99.89	99.89
First Floor	106.97	103.43	106.97	103.43
Terrace Floor	0.00	0.00	0.00	0.00
Total :	206.86	203.32	206.86	203.32

Building USE/SUBUSE Details

Building Name	Building Use	Building SubUse	Building Structure
A (AMRITA LAKRA)	Residential	Bungalow/ Dwelling / Non Apartment	Non-Highrise

LTP NAME AND SIGNATURE	STRUCTURAL ENG'S NAME AND SIGNATURE	BUILDER NAME AND SIGNATURE	DIGITAL SIGNATURE
DEEPAK DIWAN GUNPC/ARC/0003/2017			