

Section X-X

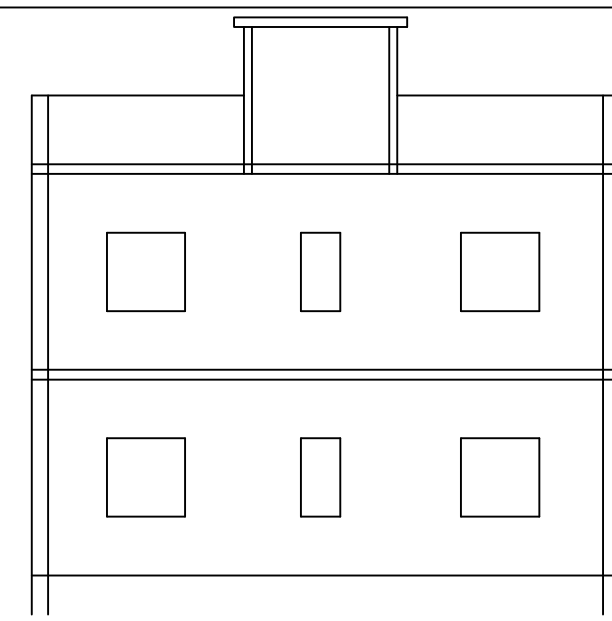

Section Y-Y

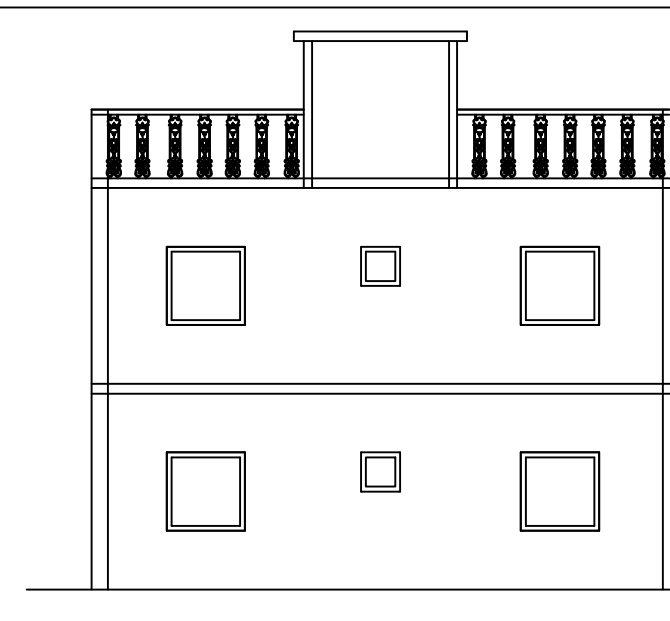

Elevation Side

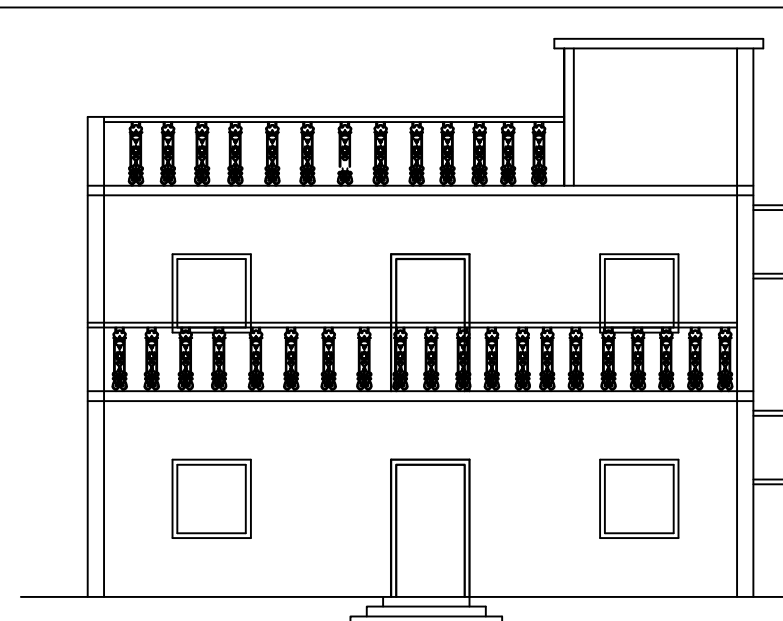

Elevation Front

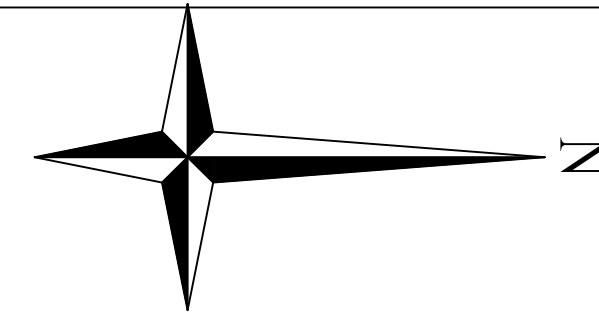
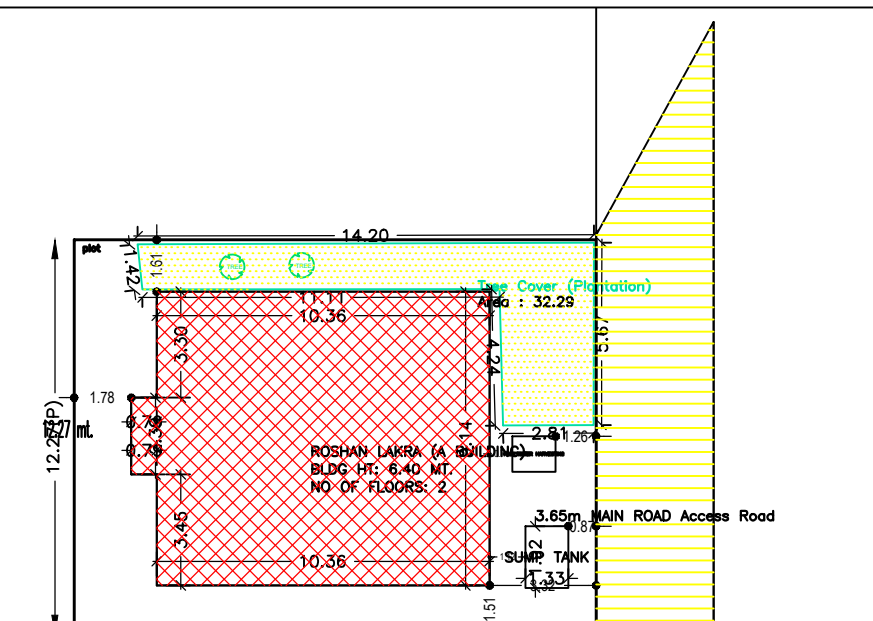

Proposal Basic Information	
Proposal File No.	GUNPC/BP/0001/W14/2023
Owner Name	ROSHAN LAKRA
Khata No	46
Plot No	39
Village Name	Karam Toli
Use	Residential
SubUse	Bungalow/ Dwelling / Non Apartment

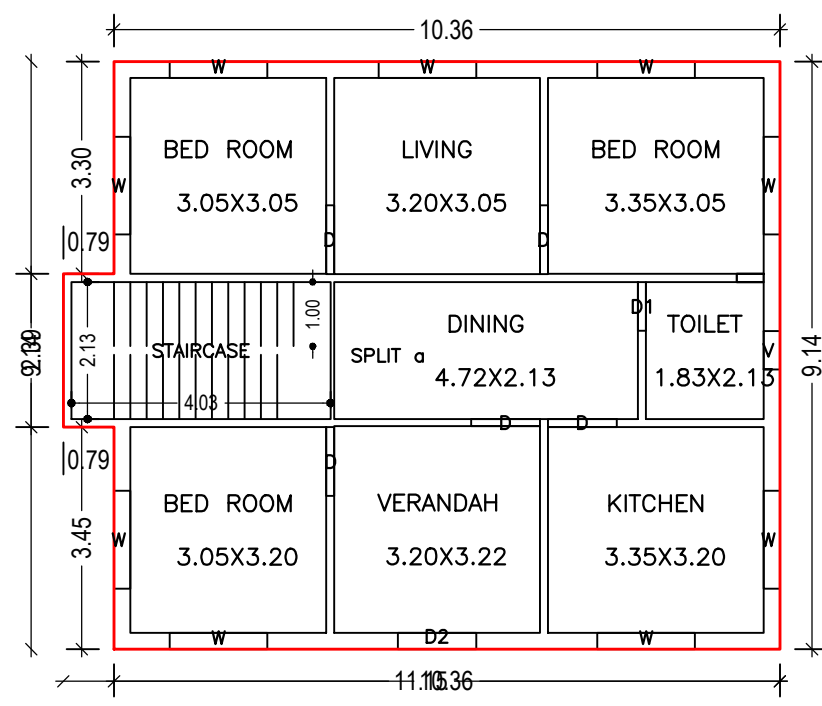

GROUND FLOOR PLAN (Proposed) (SCALE 1:100)

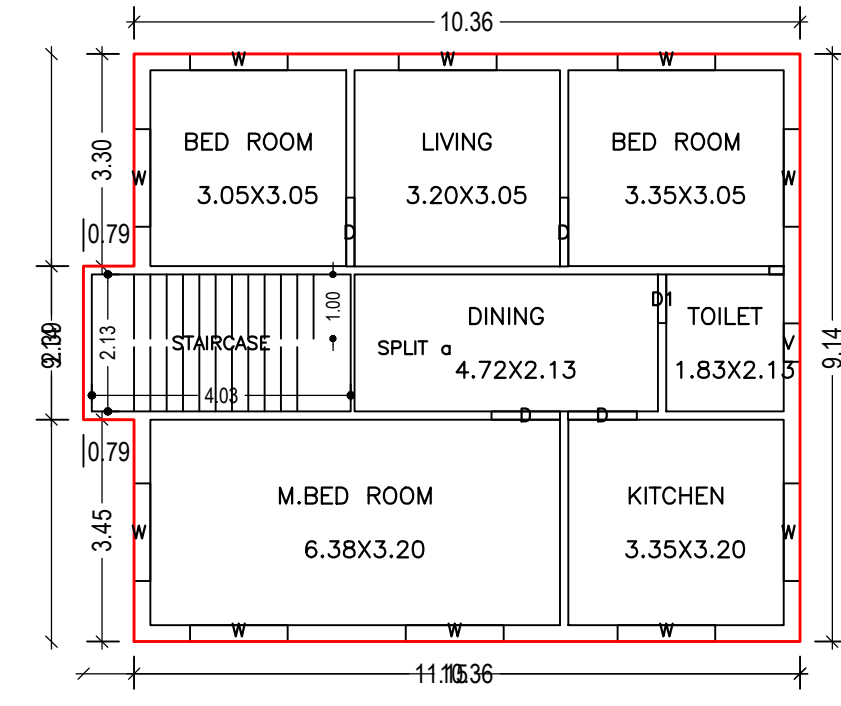

FIRST FLOOR PLAN (Proposed) (SCALE 1:100)

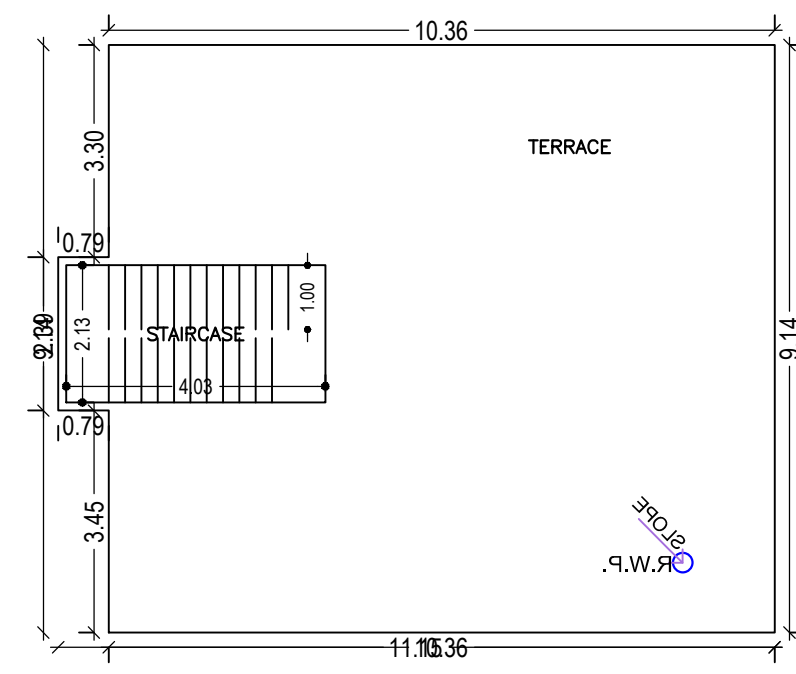

TERRACE FLOOR PLAN (SCALE 1:100)

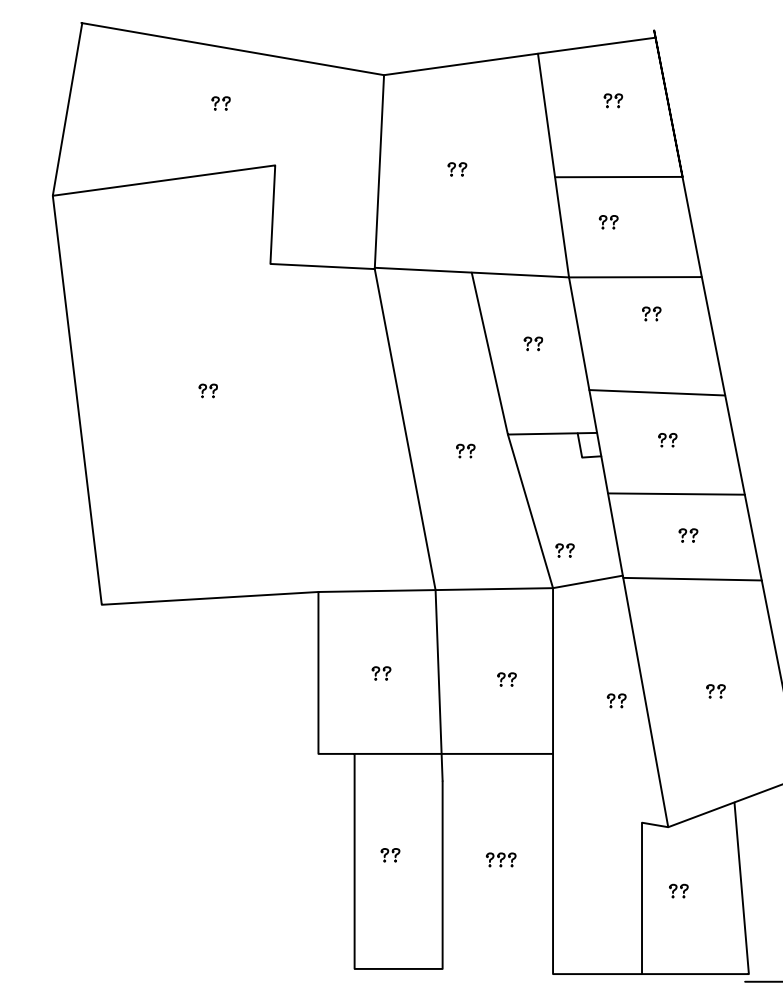

ROAD WIDE 12'

ROAD WIDE 12'

COLOR INDEX	
FLAT BOUNDARY	Green
ABUTTING ROAD	Red
PROPOSED CONSTRUCTION	Yellow
COMMON PLOT AREA	Orange
ROAD WIDENING AREA	Blue
EXISTING (To be retained)	Light Blue
EXISTING (To be demolished)	Dark Blue

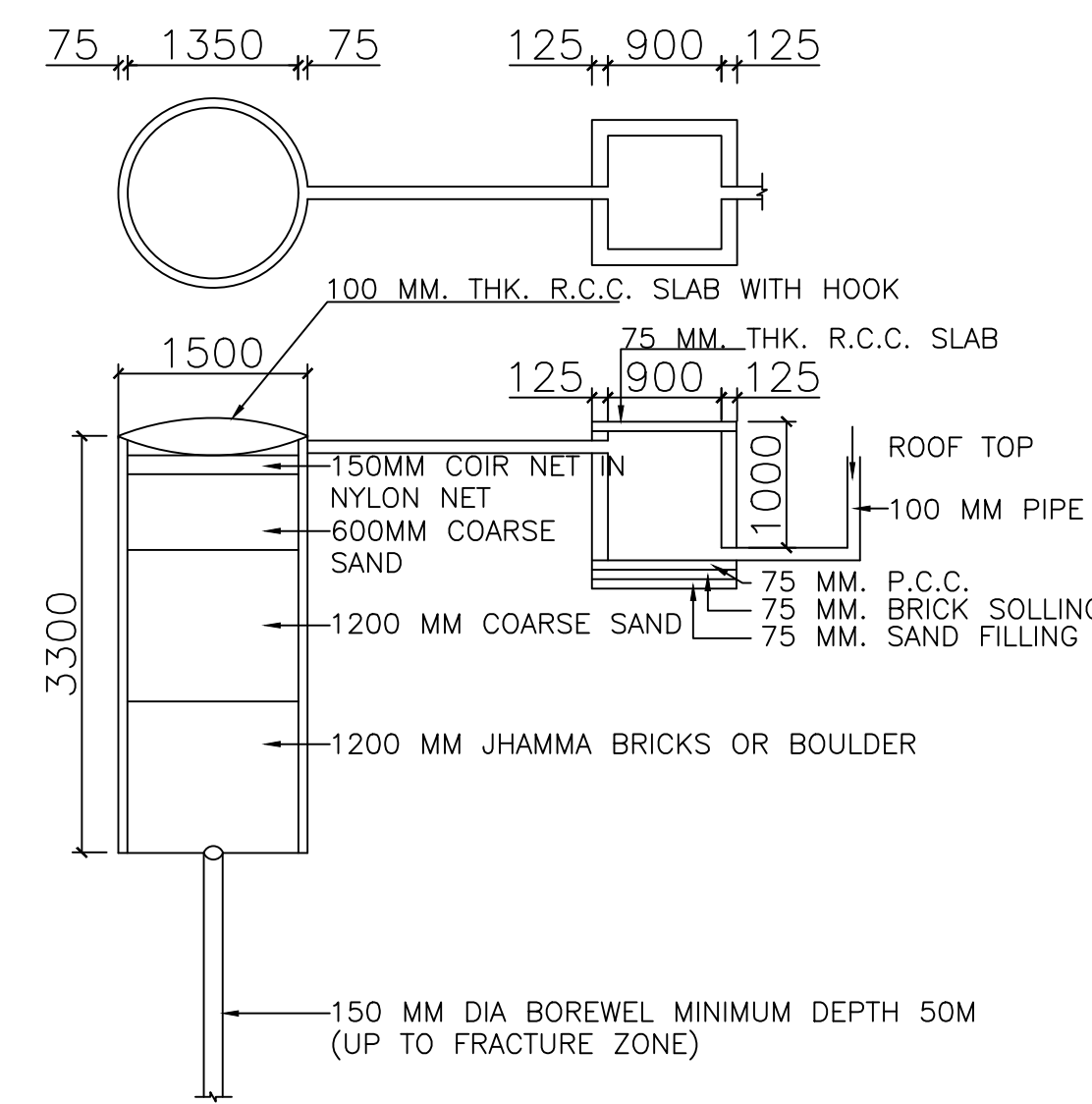

DETAIL OF GROUND WATER RECHARGE PIT WITH SILT TANK

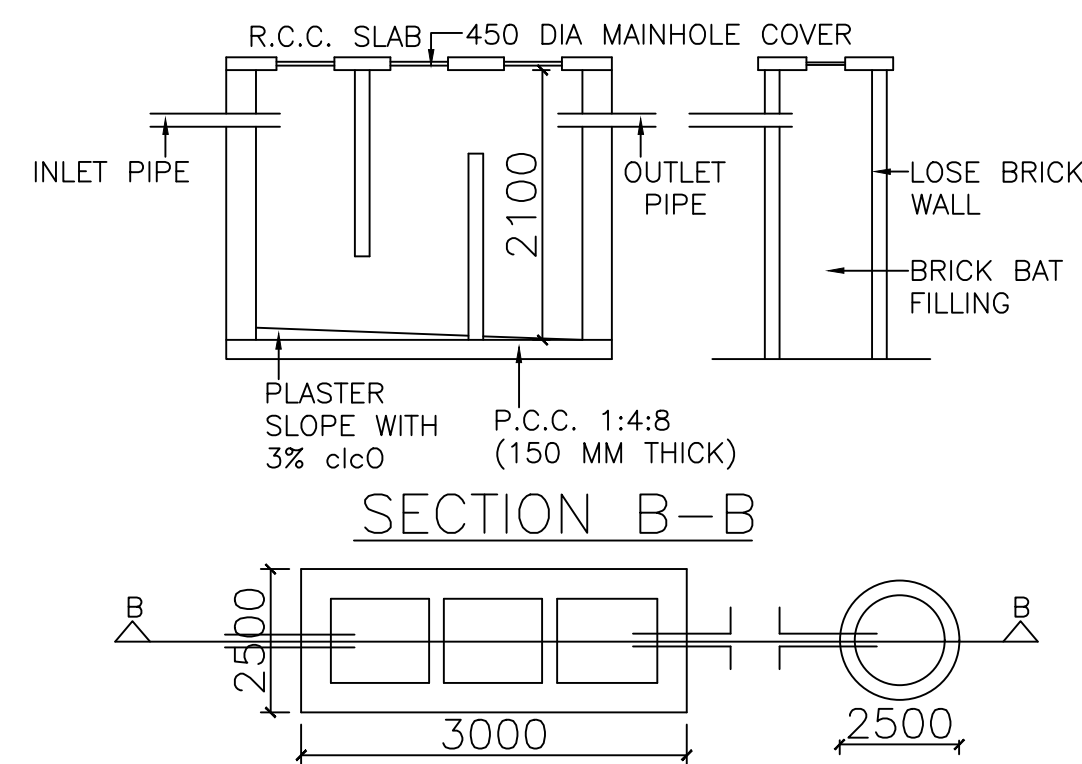

DETAIL OF SEPTIC TANK & SOAKPIT

Septic Tank Detail

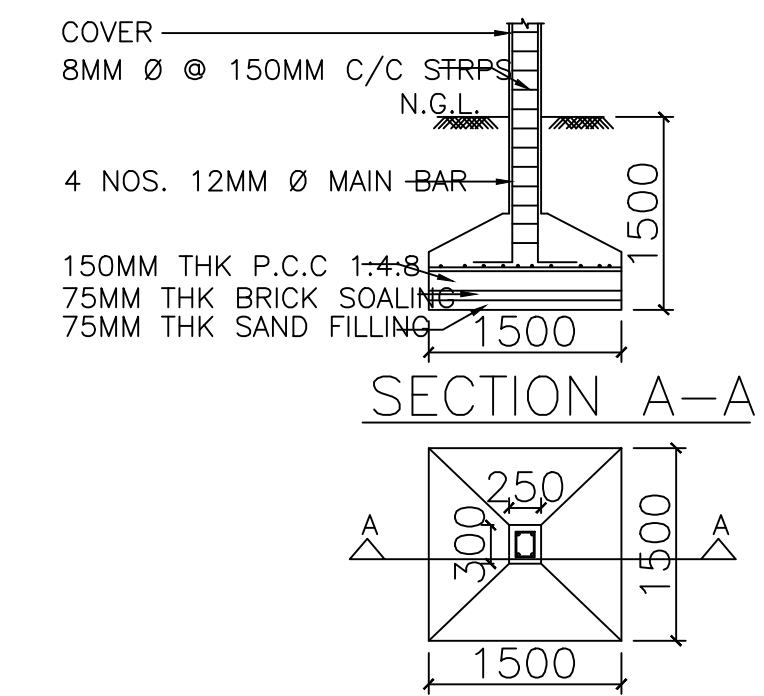

DETAIL OF FOUNDATION

Structure Detail

Building USE/SUBUSE Details

Building Name	Building Use	Building SubUse	Building Structure
ROSHAN LAKRA (A BUILDING)	Residential	Bungalow/ Dwelling / Non Apartment	Non-Highrise

SCHEDULE OF DOOR:

BUILDING NAME	NAME	LENGTH	HEIGHT	NOS
ROSHAN LAKRA (A BUILDING)	D1	0.76	2.10	02
ROSHAN LAKRA (A BUILDING)	D	1.07	2.10	09
ROSHAN LAKRA (A BUILDING)	D2	1.22	2.10	01

SCHEDULE OF WINDOW/VENTILATION:

BUILDING NAME	NAME	LENGTH	HEIGHT	NOS
ROSHAN LAKRA (A BUILDING)	V	0.60	1.20	02
ROSHAN LAKRA (A BUILDING)	W	1.52	1.20	19

Building :ROSHAN LAKRA (A BUILDING)

Floor Name	Total Built Up Area (Sq.mt.)	Proposed FAR Area (Sq.mt.)	Total FAR Area (Sq.mt.)	Total Consumed Additional FAR Area (Sq.mt.)	Tnmt (No.)
Ground Floor	96.64	96.64	96.64	96.64	01
First Floor	96.64	96.64	96.64	96.64	00
Terrace Floor	0.00	0.00	0.00	0.00	00
Total :	193.28	193.28	193.28	193.28	01

UnitBUA Table for Building :ROSHAN LAKRA (A BUILDING)

FLOOR	Name	UnitBUA Type	UnitBUA Area	Carpet Area	No. of Rooms	No. of Tenement
GROUND FLOOR PLAN	SPLIT a	FLAT	155.06	154.98	8	1
FIRST FLOOR PLAN	SPLIT a	FLAT	0.00	0.00	7	0
Total :	-	-	155.06	154.98	15	1

FAR & Tenement Details (Table 4c-1)

Building	No. of Same Bldg	Total Built Up Area (Sq.mt.)	Proposed FAR Area (Sq.mt.)	Total FAR Area (Sq.mt.)	Total Consumed Additional FAR Area (Sq.mt.)	Tnmt (No.)
ROSHAN LAKRA (A BUILDING)	1	193.28	193.28	193.28	193.28	01
Grand Total :	1	193.28	193.28	193.28	193.28	01

Buildingwise Floor FAR Details

Floor Name	Building Name		Total	
	Proposed Built Up Area (Sq.mt.)	Proposed FAR Area (Sq.mt.)	Total Proposed Built Up Area (Sq.mt.)	Total FAR Area (Sq.mt.)
Ground Floor	96.64	96.64	96.64	96.64
First Floor	96.64	96.64	96.64	96.64
Terrace Floor	0.00	0.00	0.00	0.00
Total :	193.28	193.28	193.28	193.28

AREA STATEMENT GUMLA		VERSION NO. : 1.0.66
NAGAR PARISHAD		VERSION DATE: 16/10/2020
PROJECT DETAIL :		
Region : JHARKHAND URBAN LOCAL BODIES	Plot Use: Residential	
District: GUMLA	Plot SubUse: Bungalow/ Dwelling / Non Apartment	
Authority: GUMLA NAGAR PARISHAD	PlotNearby/ReligiousStructure: NA	
Inward No: GUNPC/BP/001/W14/2023	Plot/SubPlot No: 39	
Application Type: General Proposal	North: -	
Project Type: Building Permission	South: -	
Nature of Development: New	East: -	
Location of Development Area: Old Area	West: -	
AREA DETAILS:		
AREA OF PLOT (Minimum)	(A)	SQ.MT. 199.39
NET AREA OF PLOT (Gross Plot Area - Deduction from Gross Plot area)	(A-Deductions)	199.39
Deduction for Balance Plot Area (from Gross Plot Area)		
Common Plot		32.29
Total		32.29
BALANCE AREA OF PLOT (Net Plot Area - Recreational/Amenity space)	(A-Deductions)	167.10
PLOT AREA FOR COVERAGE (Net Plot Area)	(A-Deductions)	199.39
Plot Area for FAR (Net Plot Area + Road/Widening Area)	(A-Deductions)	199.39
COVERAGE CHECK		
Permissible Coverage area ( 70.00 % )		139.57
Proposed Coverage Area ( 48.47 % )		96.64
Total Prop. Coverage Area ( 48.47 % )		96.64
Balance coverage area ( 21.53 % )		42.93
FAR CHECK		
Perm. FAR Area ( 1.500 )		299.08
Total Perm. FAR area		299.08
Residential FAR		193.28
Proposed FAR Area		193.28
Total Proposed FAR Area		193.28
Consumed FAR (Factor)		0.97
Balance FAR Area		105.80
BUILT UP AREA CHECK		
Total Proposed BuiltUp Area		193.28
ARCHITECT ( Regd )		
ARCHITECT ( Regd )		RAWNIT KUMAR
ENGINEER ( Regd )		
ENGINEER ( Regd )		
SUPERVISOR ( Regd )		
SUPERVISOR ( Regd )		ROSHAN LAKRA
OWNER ( Regd )		
OWNER ( Regd )		
DEVELOPMENT AUTHORITY		
DEVELOPMENT AUTHORITY		LOCAL BODY

LTP NAME AND SIGNATURE	STRUCTURAL ENG'S NAME AND SIGNATURE	BUILDER NAME AND SIGNATURE	DIGITAL SIGNATURE
RAWNIT KUMAR GUNPC/ENG/0004/2019			