

TYPICAL - 1& 2 FLOOR PLAN (Proposed) (SCALE 1:100)

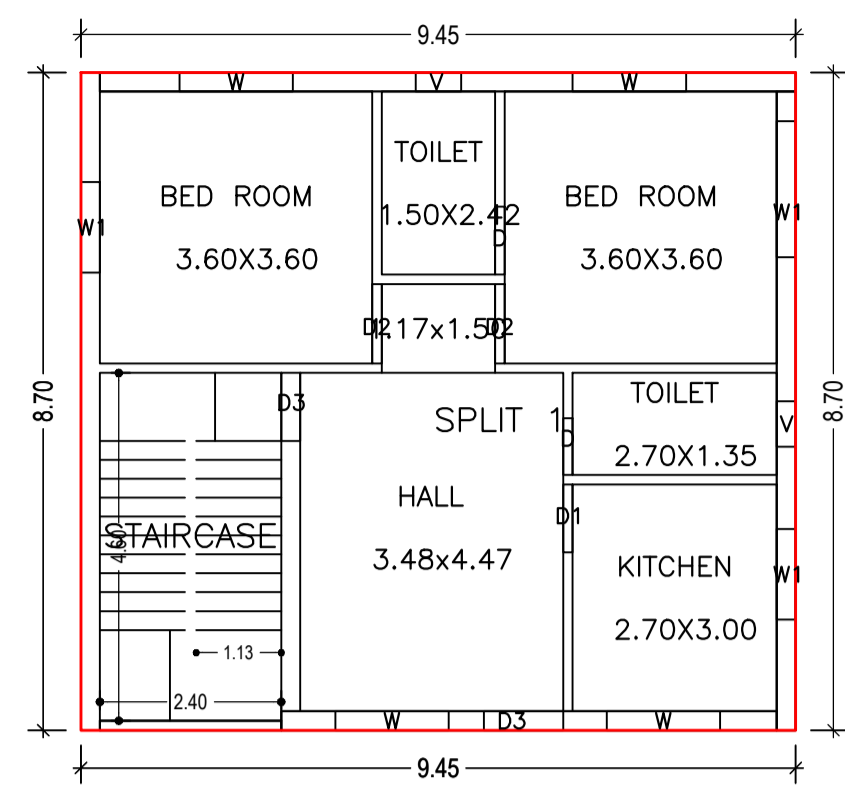

GROUND FLOOR PLAN (Proposed) (SCALE 1:100)

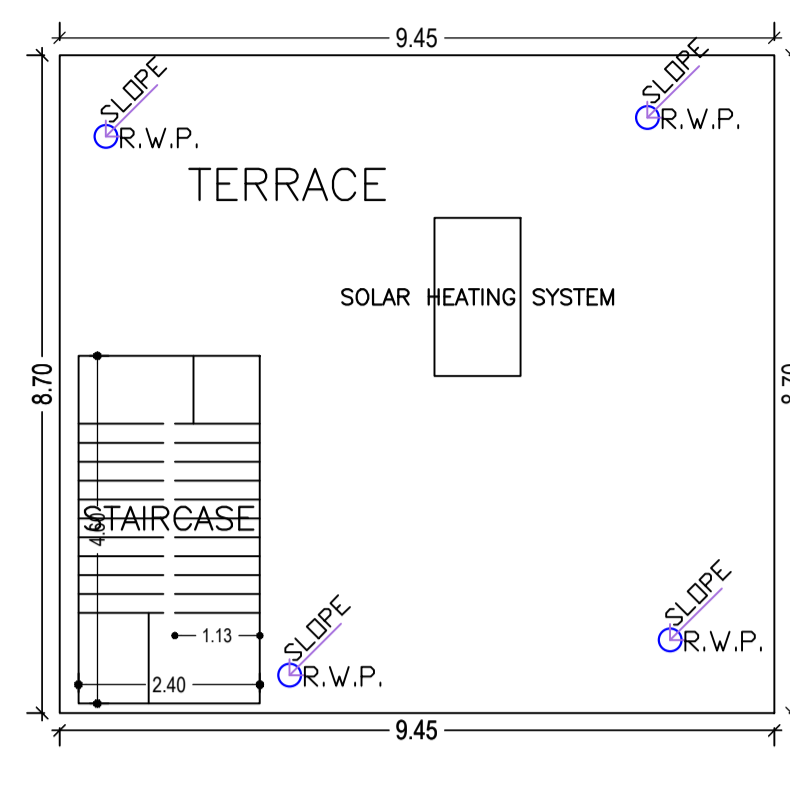

TERRACE FLOOR PLAN (SCALE 1:100)

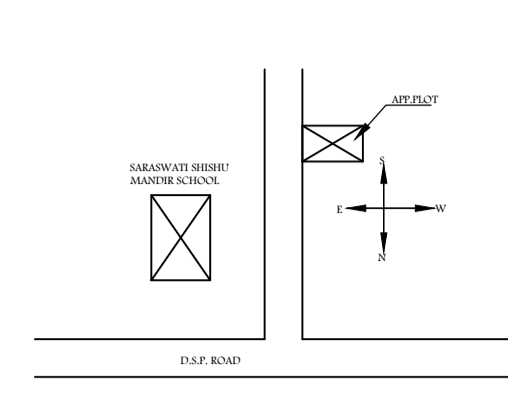
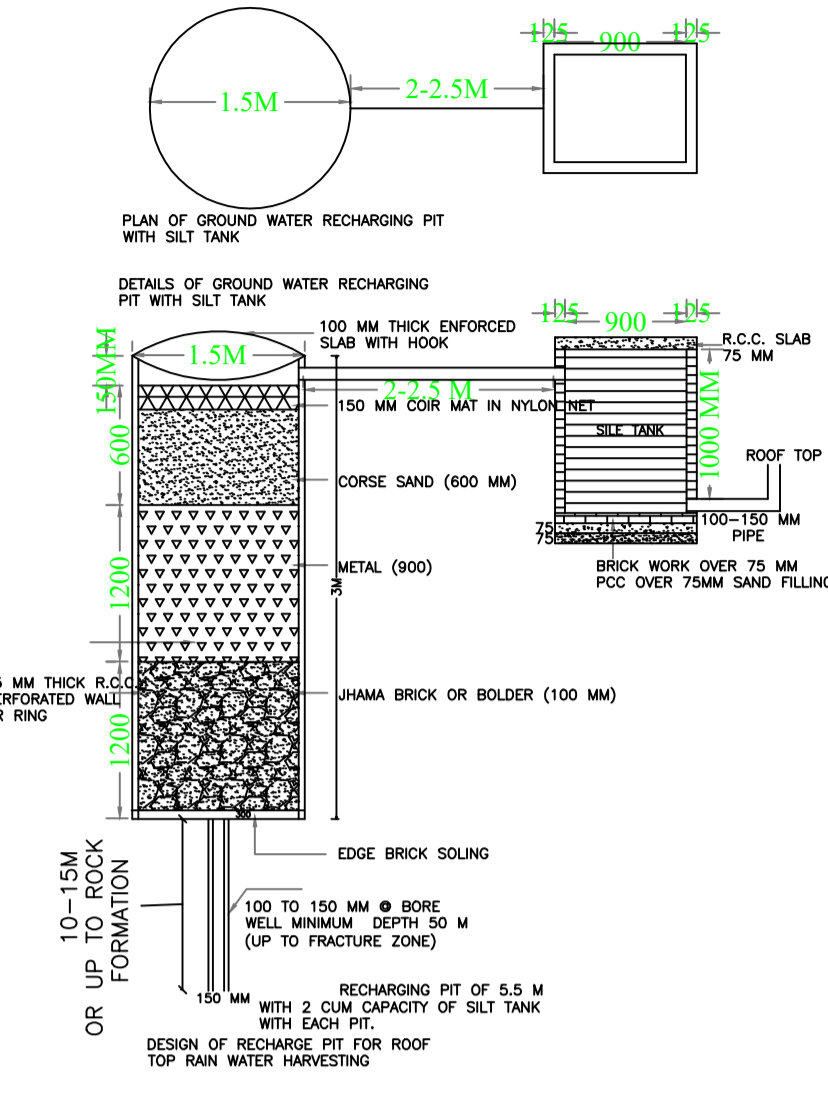

LOCATION PLAN

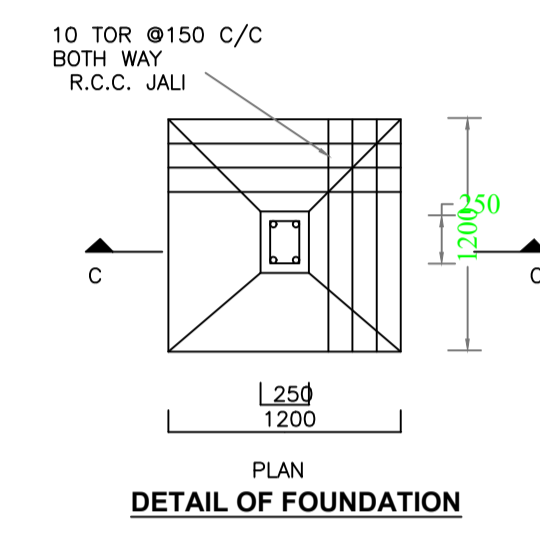

DETAIL OF FOUNDATION

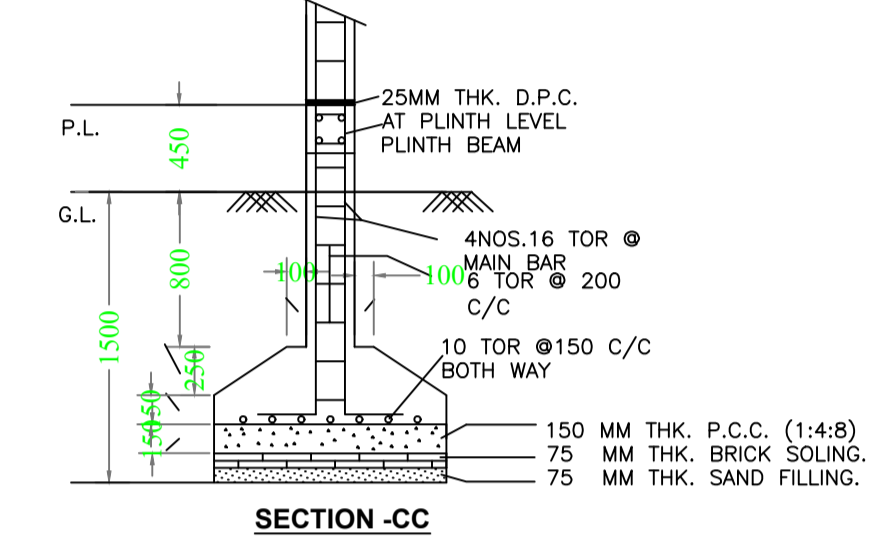

SECTION -CC

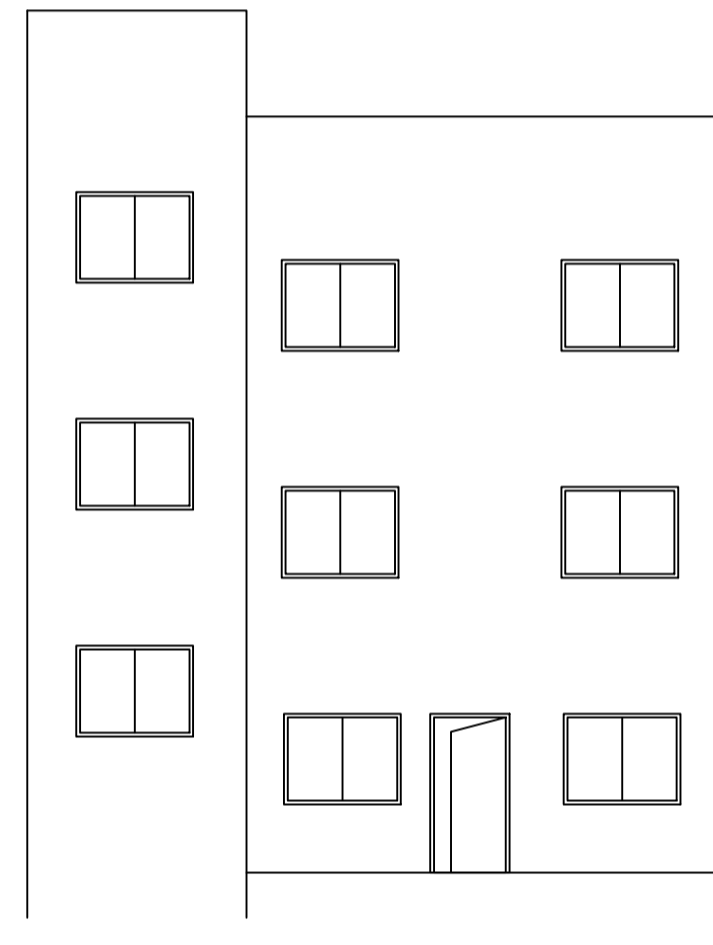

FRONT ELEVATION (SCALE 1:100)

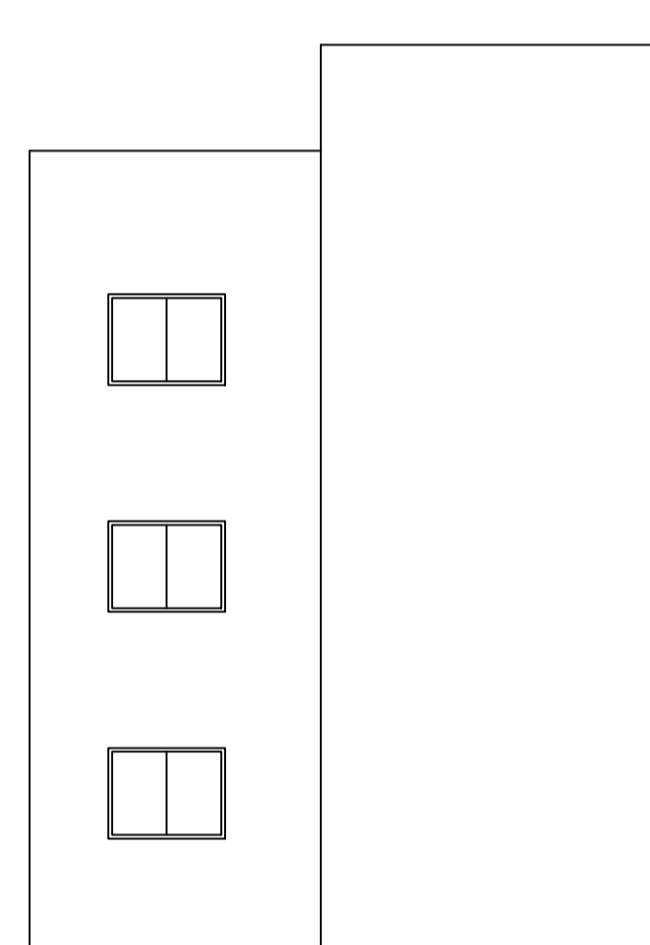

RIGHT SIDE ELEVATION (SCALE 1:100)

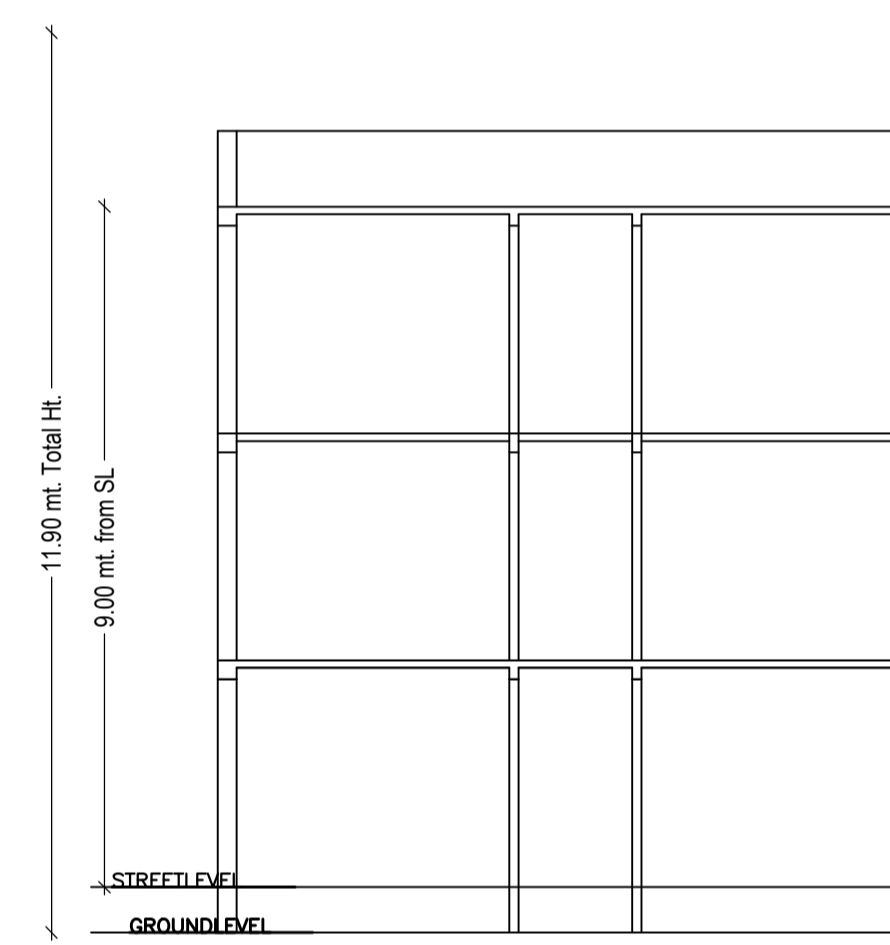

SECTION AT-X-X (SCALE 1:100)

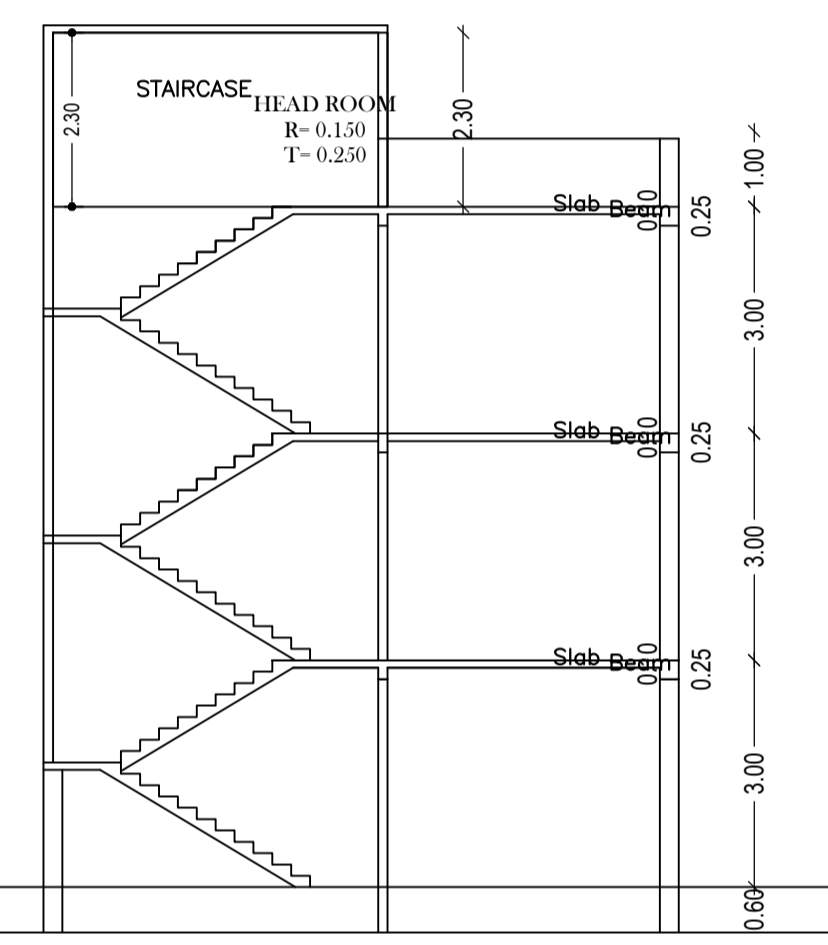

SECTION AT-Y-Y (SCALE 1:100)

SCHEDULE OF DOOR:

BUILDING NAME	NAME	LENGTH	HEIGHT	NOS
A (SHEETAL KUMARI AND SWATI KUMARI AND KAMLA DEVI)	D	0.75	2.10	03
A (SHEETAL KUMARI AND SWATI KUMARI AND KAMLA DEVI)	D	0.90	2.10	03
A (SHEETAL KUMARI AND SWATI KUMARI AND KAMLA DEVI)	D1	0.90	2.10	03
A (SHEETAL KUMARI AND SWATI KUMARI AND KAMLA DEVI)	D3	0.90	2.10	03
A (SHEETAL KUMARI AND SWATI KUMARI AND KAMLA DEVI)	D2	1.05	2.10	06
A (SHEETAL KUMARI AND SWATI KUMARI AND KAMLA DEVI)	D3	1.05	2.10	01

SCHEDULE OF WINDOW/VENTILATION:

BUILDING NAME	NAME	LENGTH	HEIGHT	NOS
A (SHEETAL KUMARI AND SWATI KUMARI AND KAMLA DEVI)	V	0.60	1.20	06
A (SHEETAL KUMARI AND SWATI KUMARI AND KAMLA DEVI)	W1	1.20	1.20	06
A (SHEETAL KUMARI AND SWATI KUMARI AND KAMLA DEVI)	W	1.50	1.20	10
A (SHEETAL KUMARI AND SWATI KUMARI AND KAMLA DEVI)	W1	1.80	1.20	03
A (SHEETAL KUMARI AND SWATI KUMARI AND KAMLA DEVI)	W	1.80	1.20	02

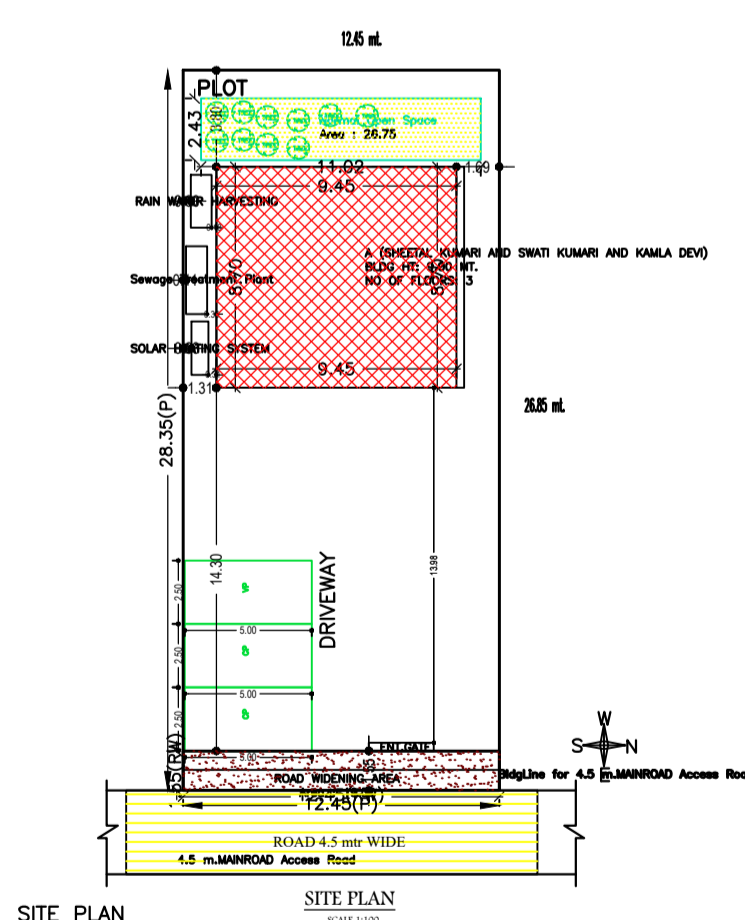

SITE PLAN

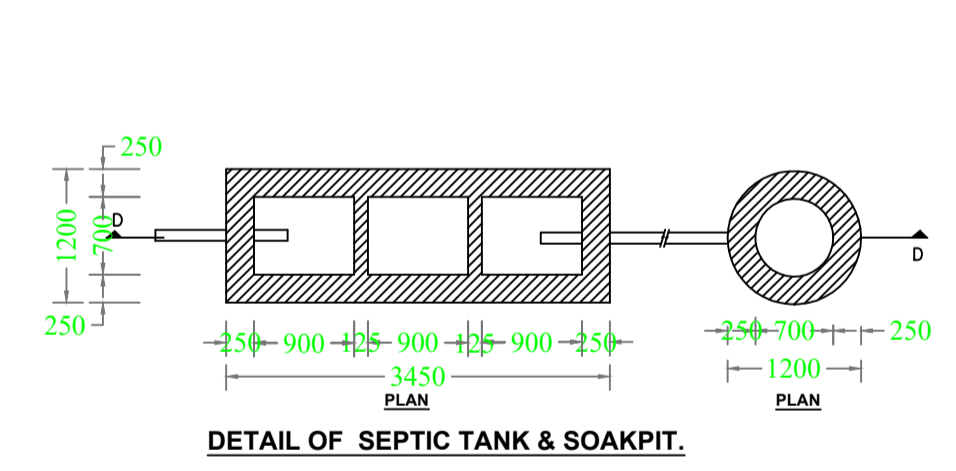

DETAIL OF SEPTIC TANK & SOAKPIT.

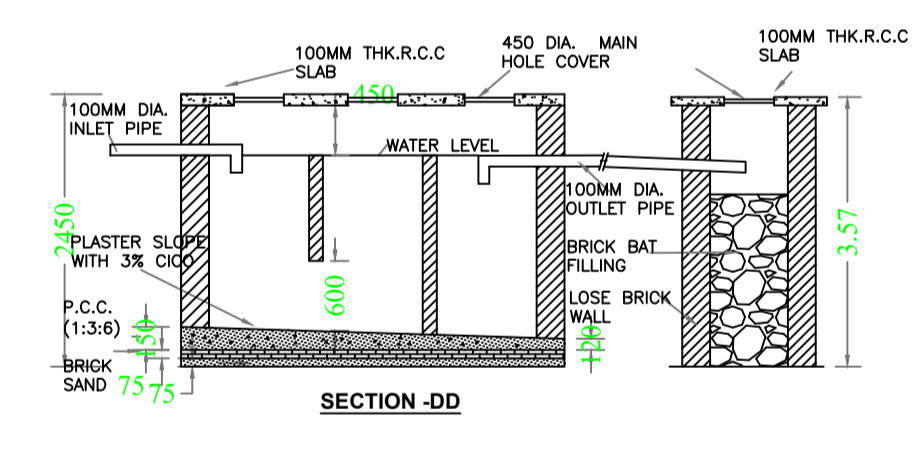

SECTION -DD

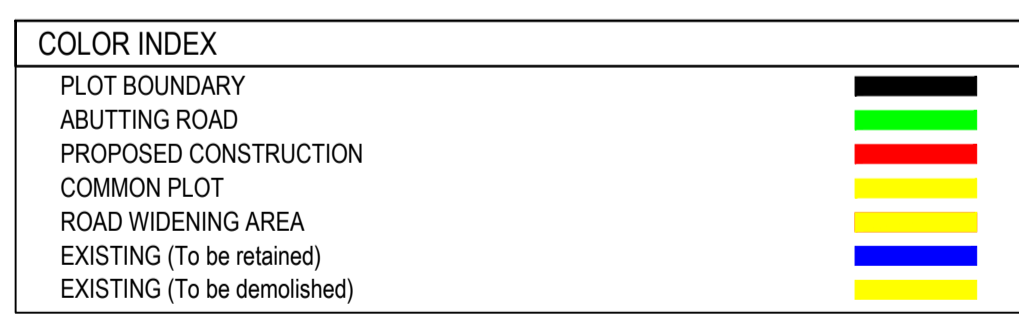

COLOR INDEX

UnitBUA Table for Building :A (SHEETAL KUMARI AND SWATI KUMARI AND KAMLA DEVI)

FLOOR	Name	UnitBUA Type	UnitBUA Area	Carpet Area	No. of Rooms	No. of Tenement
GROUND FLOOR PLAN	SPLIT 1	FLAT	246.75	223.35	6	1
TYPICAL -1& 2 FLOOR PLAN	SPLIT 1	FLAT	0.00	0.00	6	0
Total:	-	-	246.75	223.35	18	1

Building :A (SHEETAL KUMARI AND SWATI KUMARI AND KAMLA DEVI)

Floor Name	Total Built Up Area (Sq.mt.)	Proposed FAR Area (Sq.mt.)	Total FAR Area (Sq.mt.)	Total Consumed Additional FAR Area (Sq.mt.)	Tnmt (No.)
Ground Floor	82.25	82.25	82.25	82.25	01
First Floor	82.25	82.25	82.25	82.25	00
Second Floor	82.25	82.25	82.25	82.25	00
Terrace Floor	0.00	0.00	0.00	0.00	00
Total:	246.75	246.75	246.75	246.75	01
Total Number of Same Buildings :	1				
Total :	246.75	246.75	246.75	246.75	01

Buildingwise Floor FAR Details

Floor Name	Building Name		Total	
	Proposed Built Up Area (Sq.mt.)	Proposed FAR Area (Sq.mt.)	Total Proposed Built Up Area (Sq.mt.)	Total FAR Area (Sq.mt.)
Ground Floor	82.25	82.25	82.25	82.25
First Floor	82.25	82.25	82.25	82.25
Second Floor	82.25	82.25	82.25	82.25
Terrace Floor	0.00	0.00	0.00	0.00
Total :	246.75	246.75	246.75	246.75

FAR & Tenement Details (Table 4c-1)

Building	No. of Same Bldg	Total Built Up Area (Sq.mt.)	Proposed FAR Area (Sq.mt.)	Total FAR Area (Sq.mt.)	Total Consumed Additional FAR Area (Sq.mt.)	Tnmt (No.)
A (SHEETAL KUMARI AND SWATI KUMARI AND KAMLA DEVI)	1	246.75	246.75	246.75	246.75	01
Grand Total :	1	246.75	246.75	246.75	246.75	01

Building USE/SUBUSE Details

Building Name	Building Use	Building SubUse	Building Structure
A (SHEETAL KUMARI AND SWATI KUMARI AND KAMLA DEVI)	Residential	Bungalow/ Dwelling / Non Apartment	Non-Highrise

AREA STATEMENT GUMLA NAGAR PARISHAD		VERSION NO. : 1.0.65
PROJECT DETAIL:		VERSION DATE: 16/10/2020
Region: JHARKHAND URBAN LOCAL BODIES	Plot Use: Residential	
District: GUMLA	Plot SubUse: Bungalow/ Dwelling / Non Apartment	
Authority: GUMLA NAGAR PARISHAD	PlotNearbyReligiousStructure: NA	
Inward No: GUNPC/BP/004/W/17/2023	Plot/SubPlot No: 886	
Application Type: General Proposal	North: -	
Project Type: Building Permission	South: -	
Nature of Development: New	East: -	
Location of Development Area: Old Area	West: -	
AREA DETAILS:		SQ.MT.
AREA OF PLOT (Minimum)	(A)	352.95
Deduction for NetPlot Area		
Road Widening Area		19.30
Total		19.30
NET AREA OF PLOT(Gross Plot Area - Deduction from Gross Plot area)	(A-Deductions)	333.65
Deduction for Balance Plot Area(from Gross Plot Area)		
Road Widening Area		19.30
Common Plot		26.75
Total		46.05
BALANCE AREA OF PLOT(Net Plot Area - Recreational/Amenity space)	(A-Deductions)	306.90
PLOT AREA FOR COVERAGE(Net Plot Area)	(A-Deductions)	333.65
Plot Area for FAR (Net Plot Area + RoadWidening Area)	(A-Deductions)	333.65
COVERAGE CHECK		
Permissible Coverage area (60.00 %)		200.19
Proposed Coverage Area (24.65 %)		82.25
Total Prop. Coverage Area (24.65 %)		82.25
Balance coverage area (35.35 %)		117.94
FAR CHECK		
Perm. FAR Area (1.500)		500.47
Total Perm. FAR area		500.47
Residential FAR		246.75
Proposed FAR Area		246.75
Total Proposed FAR Area		246.75
Consumed FAR (Factor)		0.74
Balance FAR Area		253.72
BUILT UP AREA CHECK		
Total Proposed BuiltUp Area		246.75
ARCHITECT (Regd)	DEEPAK DIWAN	
ENGINEER (Regd)		
SUPERVISOR (Regd)		
OWNER (Regd)	KAMLA DEVI AND SHEETAL KUMARI AND SWATI KUMARI	
DEVELOPMENT AUTHORITY	LOCAL BODY	

LTP NAME AND SIGNATURE	STRUCTURAL ENG'S NAME AND SIGNATURE	BUILDER NAME AND SIGNATURE	DIGITAL SIGNATURE
DEEPAK DIWAN GUNPC/ARC/0003/2017			