

SECTION AT-XX  
SCALE 1:100

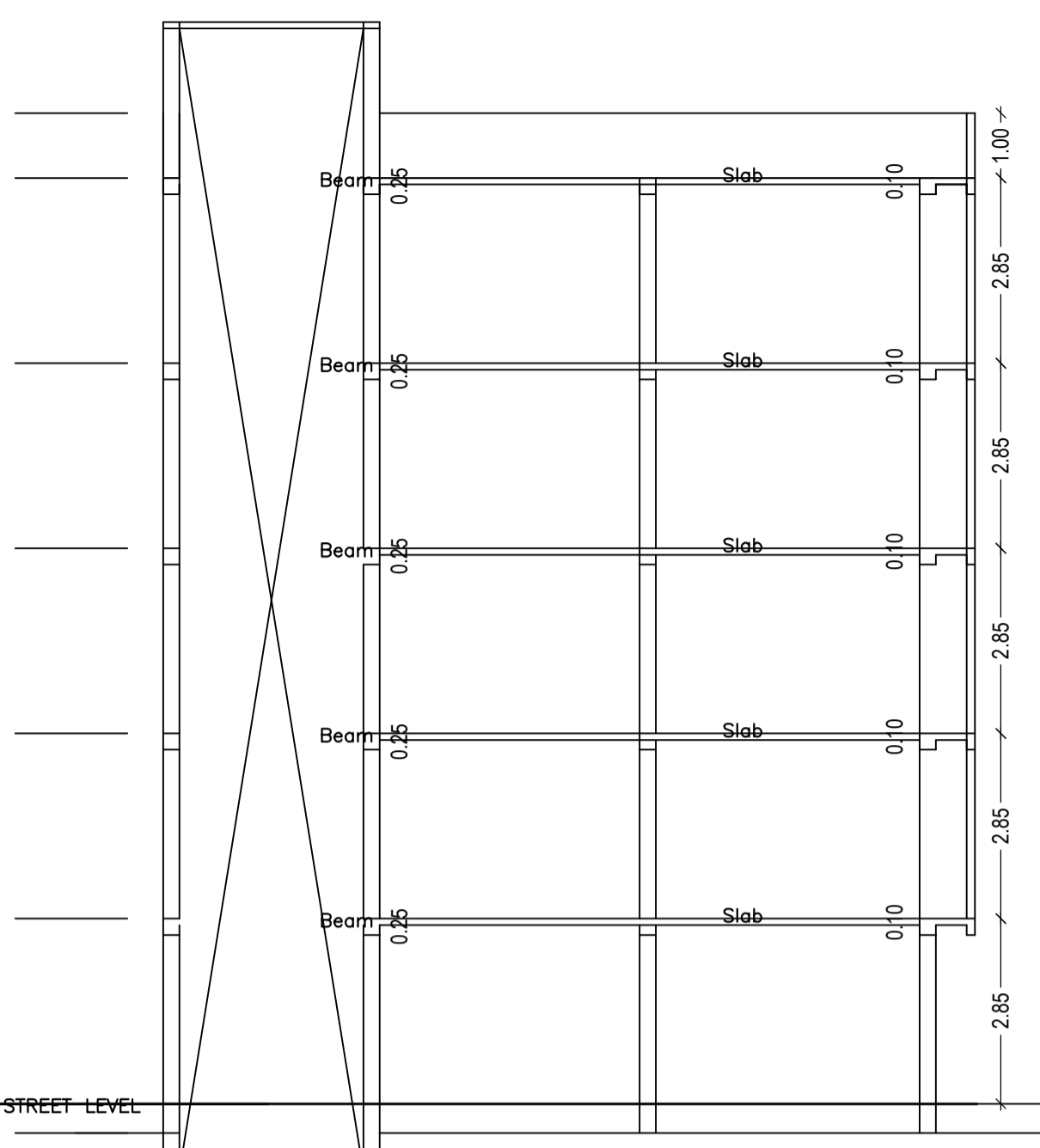

SECTION AT-YY  
SCALE 1:100

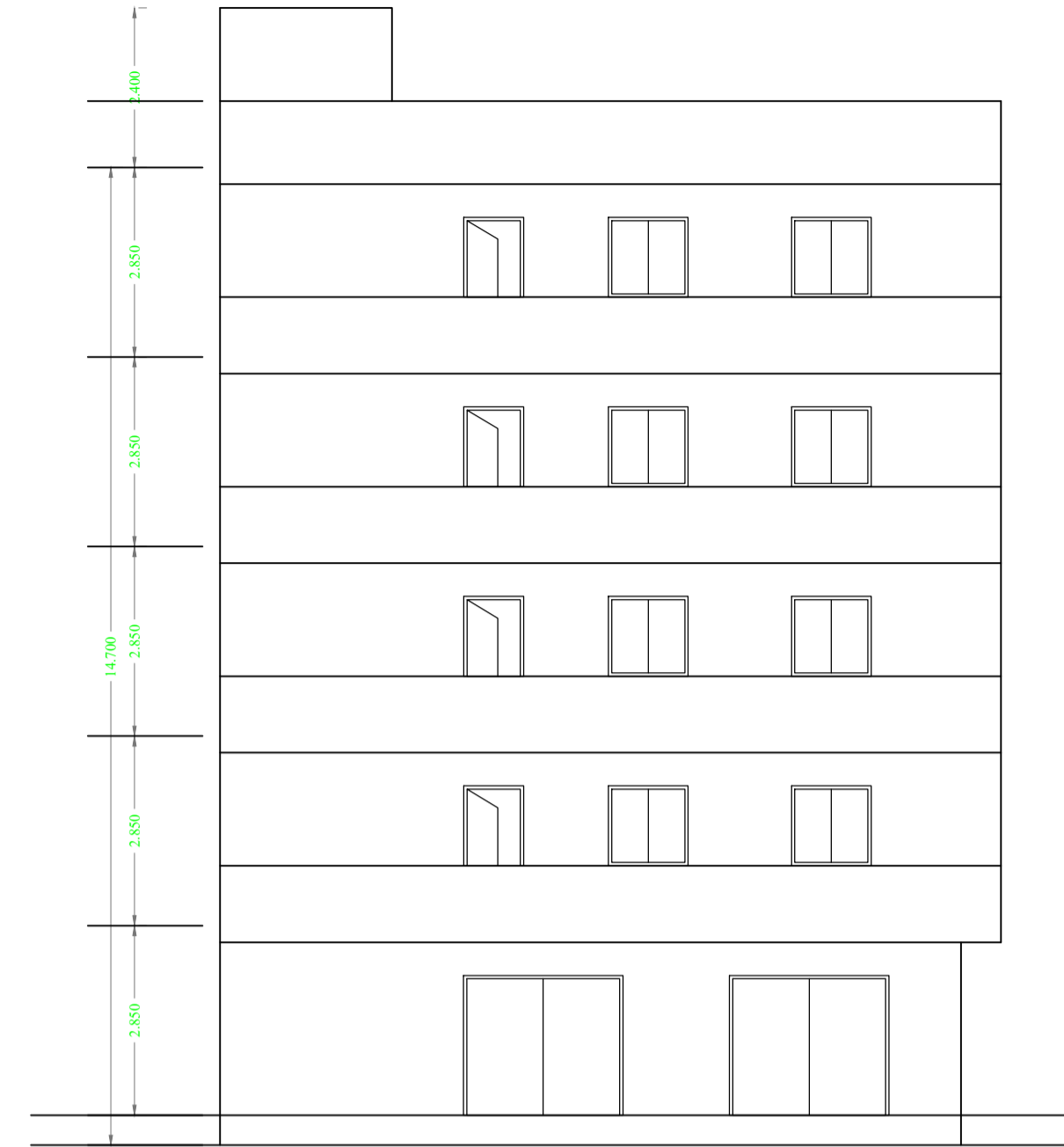

FRONT ELEVATION  
SCALE 1:100

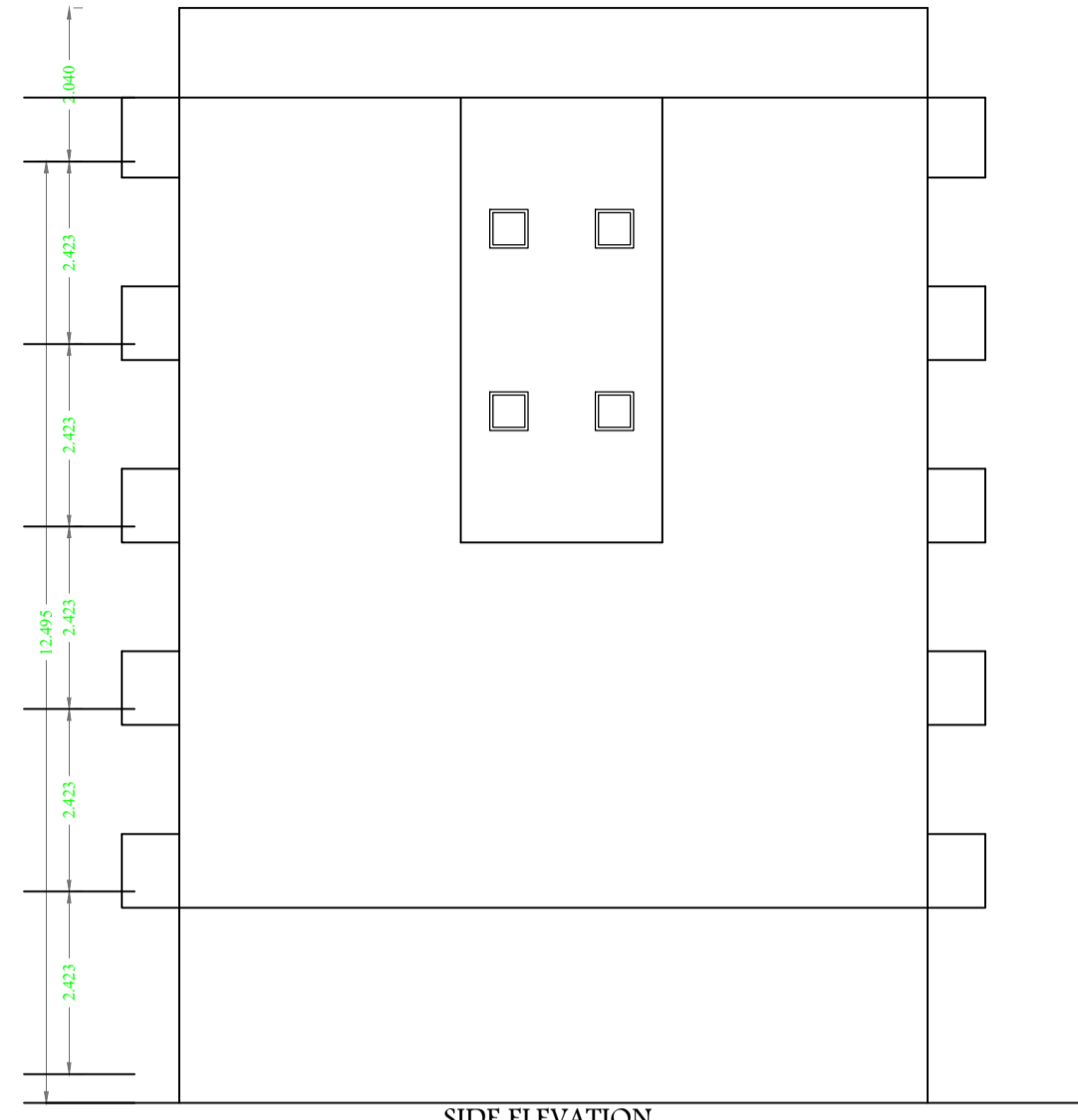

SIDE ELEVATION  
SCALE 1:100

Proposal Basic Information

Proposal File No.	GUNPC/BP/0013/W20/2023
Owner Name	CHANDRASEH THAKUR AND CHINTA DEVI
Khata No	439,439
Plot No	960,960
Village Name	Jawahar Nagar
Use	Mixed
SubUse	Resi+Comm

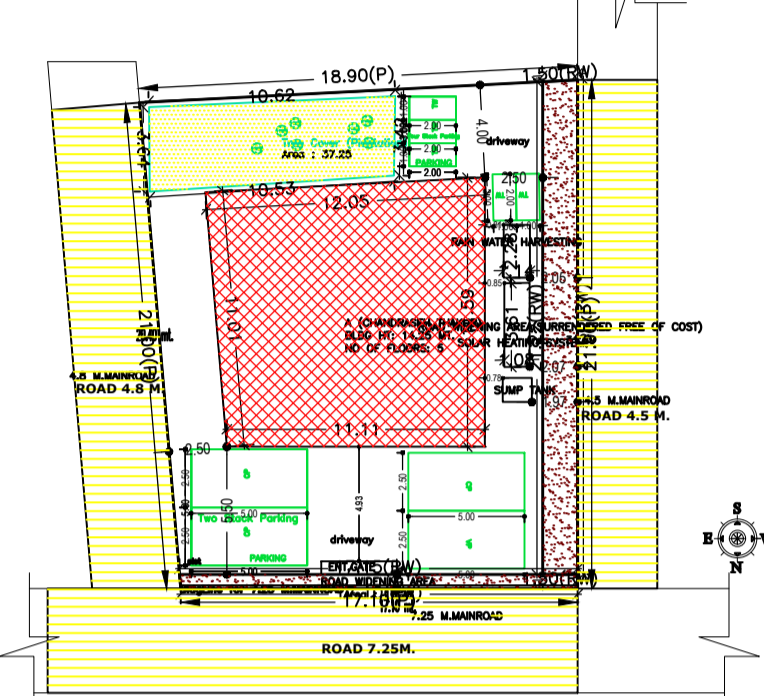

PROPOSED SITE PLAN

Balcony Calculations Table

FLOOR	SIZE	AREA	TOTAL AREA
TYPICAL - 1&2 FLOOR PLAN	0.90 X 1.71 X 1 X 2	21.99	43.98
TYPICAL - 3&4 FLOOR PLAN	0.90 X 1.71 X 1 X 2	22.82	43.88
Total		87.75	

Buildingwise Floor FAR Details

Floor Name	A (CHANDRASEH THAKUR)		Total	
	Proposed Built Up Area (Sq.mt.)	Proposed FAR Area (Sq.mt.)	Total Proposed Built Up Area (Sq.mt.)	Total FAR Area (Sq.mt.)
Ground Floor	130.66	130.66	130.66	130.66
First Floor	159.56	134.47	159.56	134.47
Second Floor	159.56	134.47	159.56	134.47
Third Floor	157.67	132.58	157.67	132.58
Fourth Floor	157.67	132.58	157.67	132.58
Terrace Floor	0.00	0.00	0.00	0.00
Total	765.12	664.76	765.12	664.76

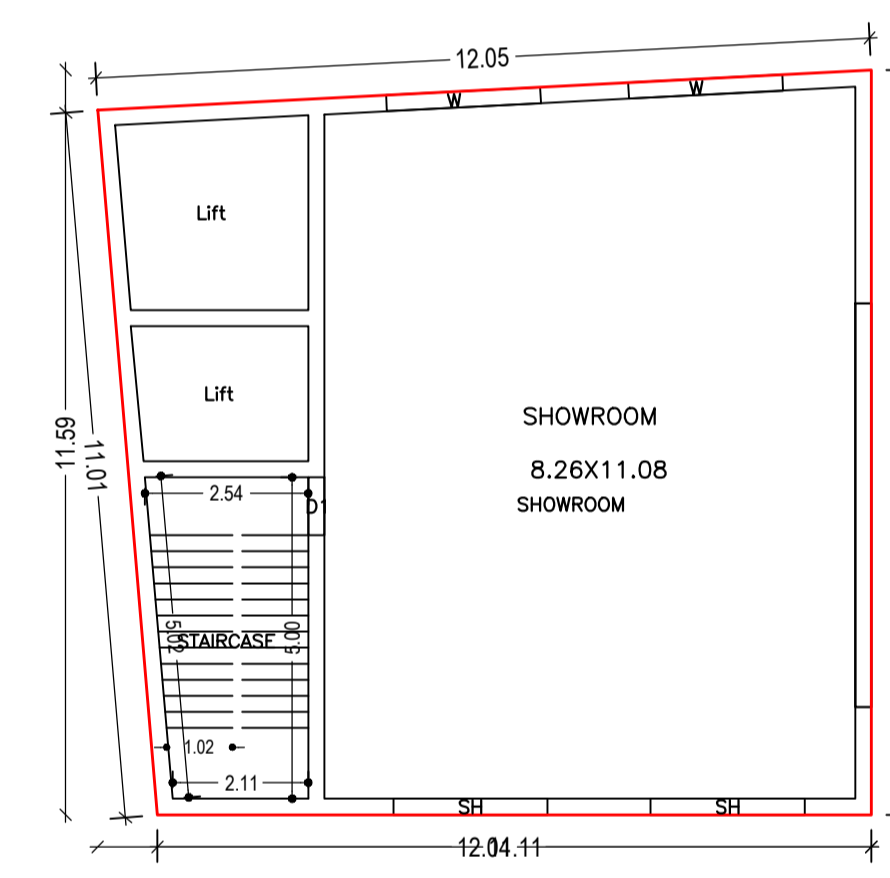

GROUND FLOOR PLAN  
(Proposed)  
SCALE 1:100

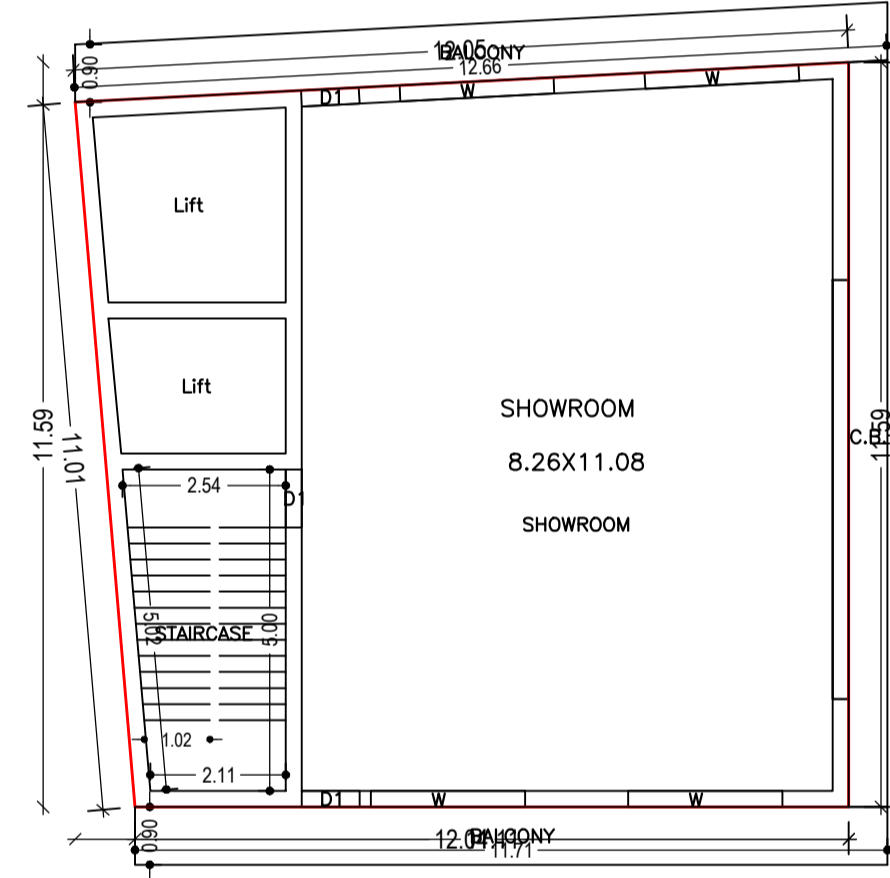

TYPICAL - 1 & 2 FLOOR PLAN  
(Proposed)  
SCALE 1:100

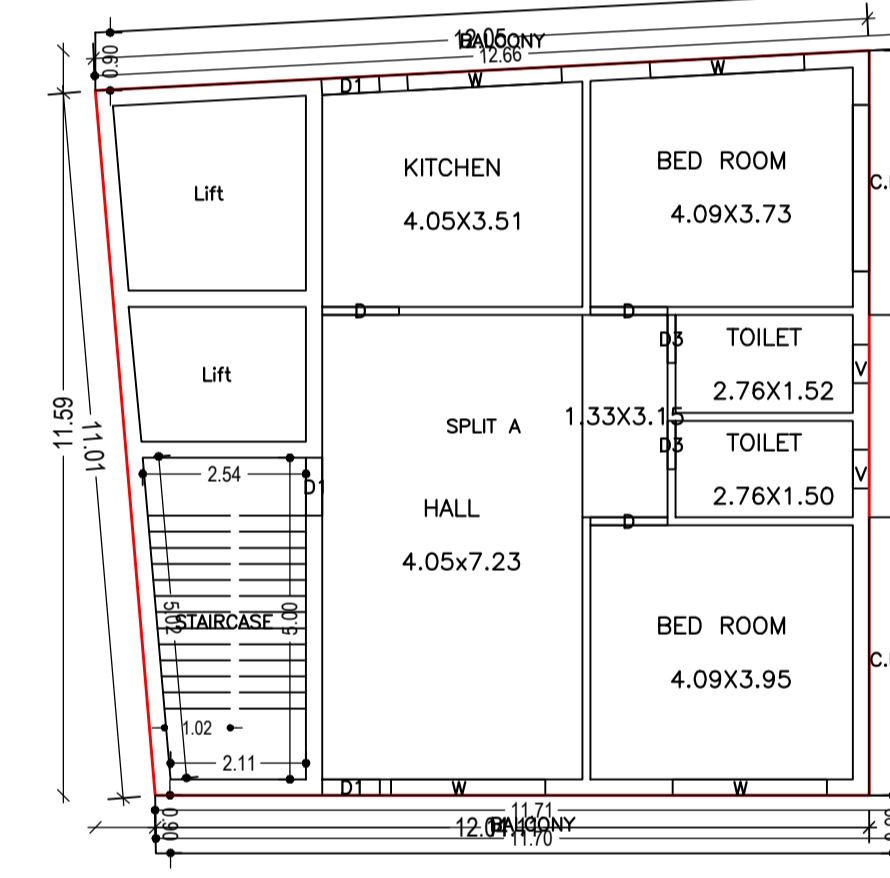

TYPICAL - 3 & 4 FLOOR PLAN  
(Proposed)  
SCALE 1:100

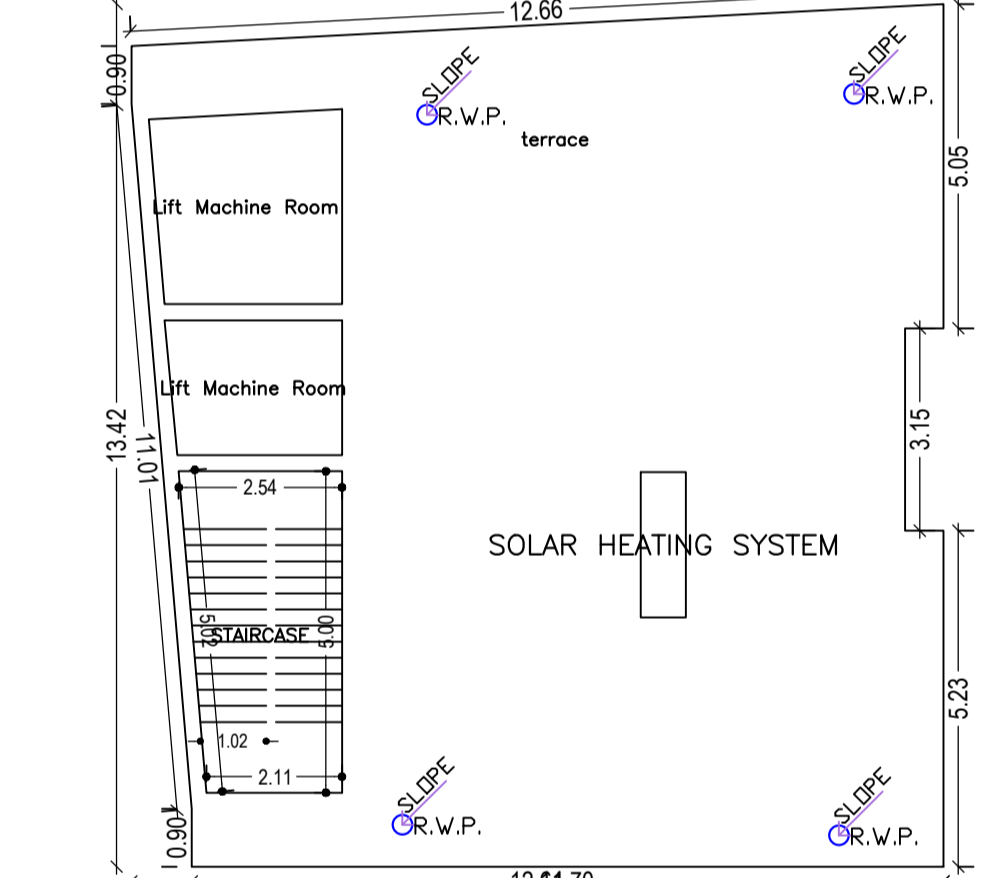

TERRACE FLOOR PLAN  
(SCALE 1:100)

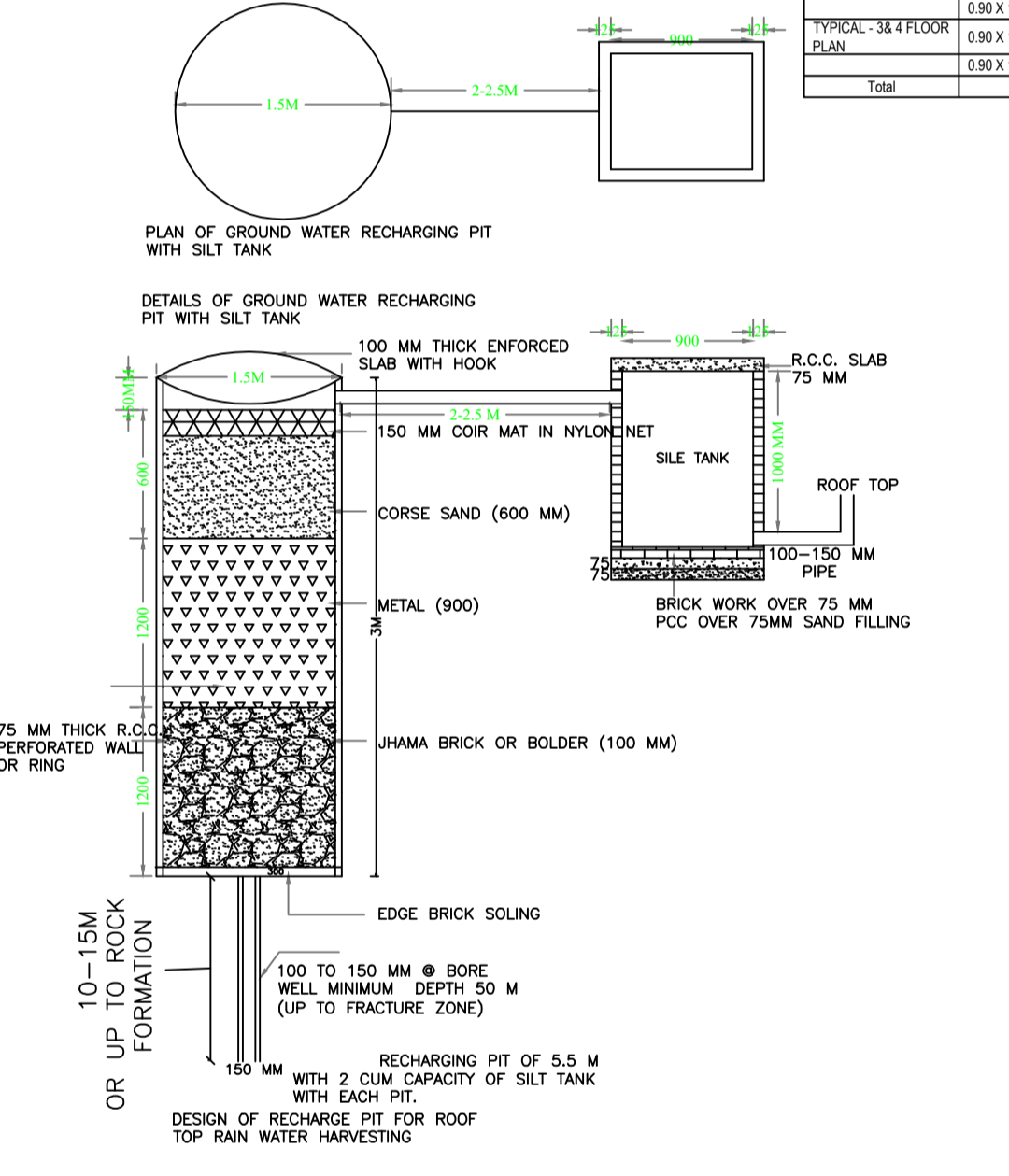

DETAILS OF GROUND WATER RECHARGING PIT WITH SILT TANK

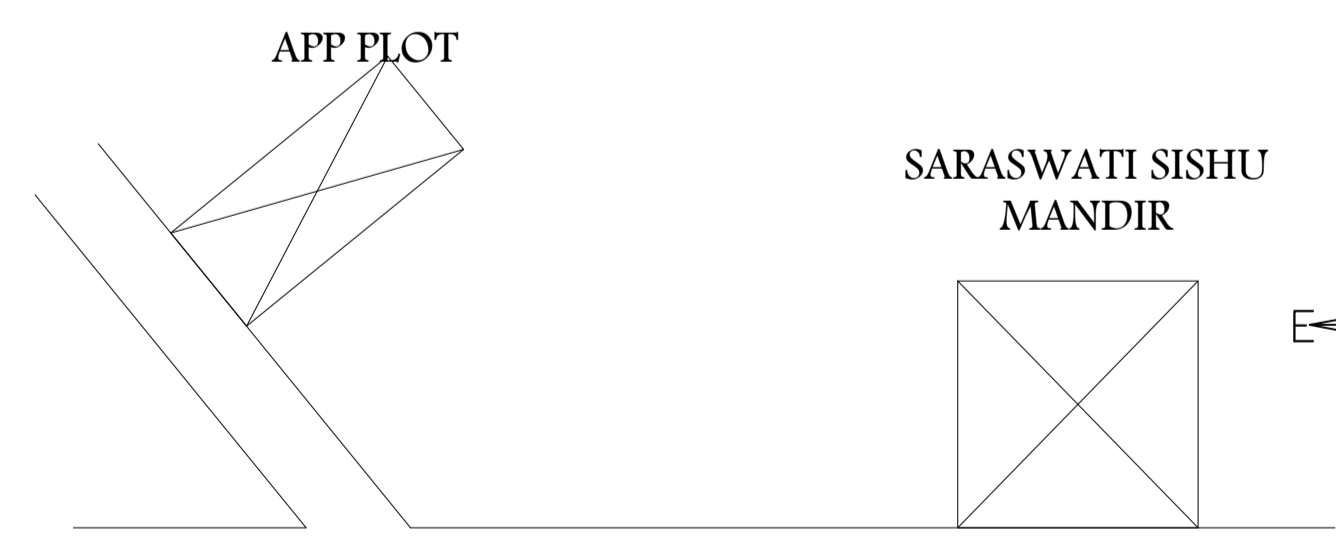

D.S.P. ROAD

COLOR INDEX

PLOT BOUNDARY	Black
ABUTTING ROAD	Green
PROPOSED CONSTRUCTION	Red
COMMON PLOT	Yellow
ROAD WIDENING AREA	Blue
EXISTING (To be retained)	Orange
EXISTING (To be demolished)	Grey

SCHEDULE OF DOOR:

BUILDING NAME	NAME	LENGTH	HEIGHT	NO.
A (CHANDRASEH THAKUR)	D3	0.75	2.10	04
A (CHANDRASEH THAKUR)	D1	0.90	2.10	13
A (CHANDRASEH THAKUR)	D	1.20	2.10	08
A (CHANDRASEH THAKUR)	D4	2.40	2.10	02

SCHEDULE OF WINDOW/VENTILATION:

BUILDING NAME	NAME	LENGTH	HEIGHT	NO.
A (CHANDRASEH THAKUR)	V	0.60	1.20	04
A (CHANDRASEH THAKUR)	W	2.40	1.20	18

Building USE/SUBUSE Details

Building Name	Building Use	Building SubUse	Building Structure
A (CHANDRASEH THAKUR)	Commercial	ResiComm Bldg	Non-Highrise

LOCTION MAP  
SCALE N.T.S.

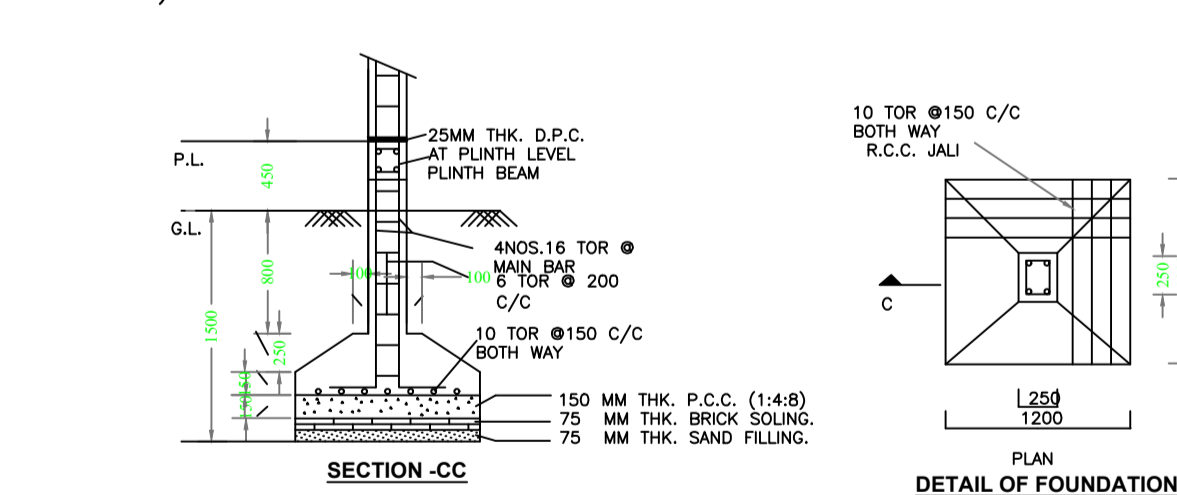

SECTION-CC and SECTION-DD

UnitBUA Table for Building :A (CHANDRASEH THAKUR)

FLOOR	Name	UnitBUA Type	UnitBUA Area	Carpet Area	No. of Rooms	No. of Tenement
GROUND FLOOR PLAN	SHOWROOM	SHOP	116.53	114.96	1	1
TYPICAL - 1& 2 FLOOR PLAN	SHOWROOM	SHOP	138.48	114.91	1	2
TYPICAL - 3& 4 FLOOR PLAN	SPLIT A	FLAT	138.47	115.89	6	2
Total:			670.44	576.54	15	5

FAR & Tenement Details (Table 4c-1)

Building	No. of Same Bldg	Total Built Up Area (Sq.mt.)	Deductions (Area in Sq.mt.)		Proposed FAR Area (Sq.mt.)		Total FAR Area (Sq.mt.)	Total Consumed Additional FAR Area (Sq.mt.)	Trmt (No.)
			Lift	Balcony	Resi.	Commercial			
A (CHANDRASEH THAKUR)	1	765.12	56.48	43.88	265.16	399.60	664.76	664.76	05
Grand Total	1	765.12	56.48	43.88	265.16	399.60	664.76	664.76	05

Required Parking (Table 7a)

Building Name	Type	SubUse	Area (Sq.mt.)	Units		Car		Visitors Car		TwoWheeler	
				Reqd./Unit	Prop.	Reqd./Unit	Prop.	Reqd./Unit	Prop.	Reqd./Unit	Prop.
A (CHANDRASEH THAKUR)	Commercial	ResiComm Bldg	> 0	100	350.59	1	3	-	-	-	-
	Residential	Residential Bldg/Apartment	> 0	1	2.00	1	2	-	-	-	-
Total			> 0	101	352.59	2	5	-	-	-	-

Parking Check (Table 7b)

Vehicle Type	No.	Area	Prop.	
			No.	Area
Car	-	-	3	37.50
Two Stack Car	-	-	2	25.00
Total Car	5	62.50	5	62.50
Visitor's Car Parking	-	-	1	12.50
Total Visitor Parking	1	12.50	1	12.50
TwoWheeler	-	-	4	8.00
Four Stack	-	-	6	12.00
Total TwoWheeler	10	20.00	10	20.00
Total	15	95.00	15	115.00

Building :A (CHANDRASEH THAKUR)

Floor Name	Total Built Up Area (Sq.mt.)	Deductions (Area in Sq.mt.)		Proposed FAR Area (Sq.mt.)	Total FAR Area (Sq.mt.)	Total Consumed Additional FAR Area (Sq.mt.)	Trmt (No.)
		Lift	Balcony				
Ground Floor	130.66	0.00	0.00	130.66	130.66	130.66	01
First Floor	159.56	14.12	10.97	134.47	134.47	134.47	01
Second Floor	159.56	14.12	10.97	134.47	134.47	134.47	01
Third Floor	157.67	14.12	10.97	132.58	132.58	132.58	01
Fourth Floor	157.67	14.12	10.97	132.58	132.58	132.58	01
Terrace	0.00	0.00	0.00	0.00	0.00	0.00	00
Total:	765.12	56.48	43.88	265.16	399.60	664.76	05

LTP NAME AND SIGNATURE: DEEPAK DIWAN, GUNPC/ARC/0003/2017