

Proposal Basic Information	
Proposal File No.	GUNPC/BP/0027/W13/2023
Owner Name	SANTOSH KUMAR KESHRI
Khata No	21
Plot No	642
Village Name	Chetar
Use	Mixed
SubUse	Res+Comm

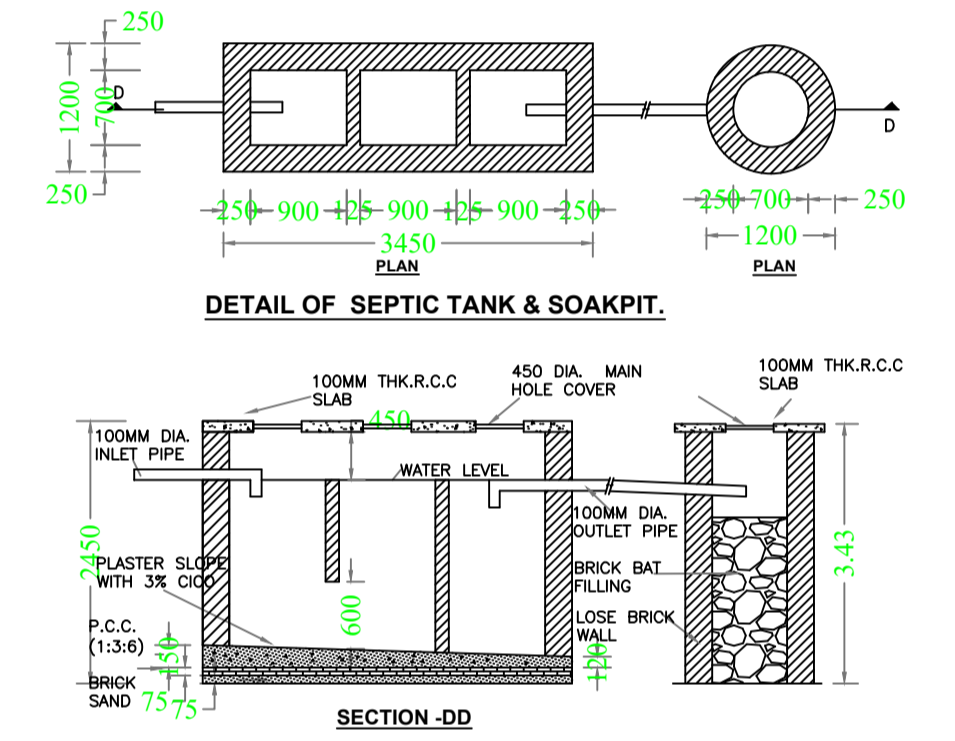
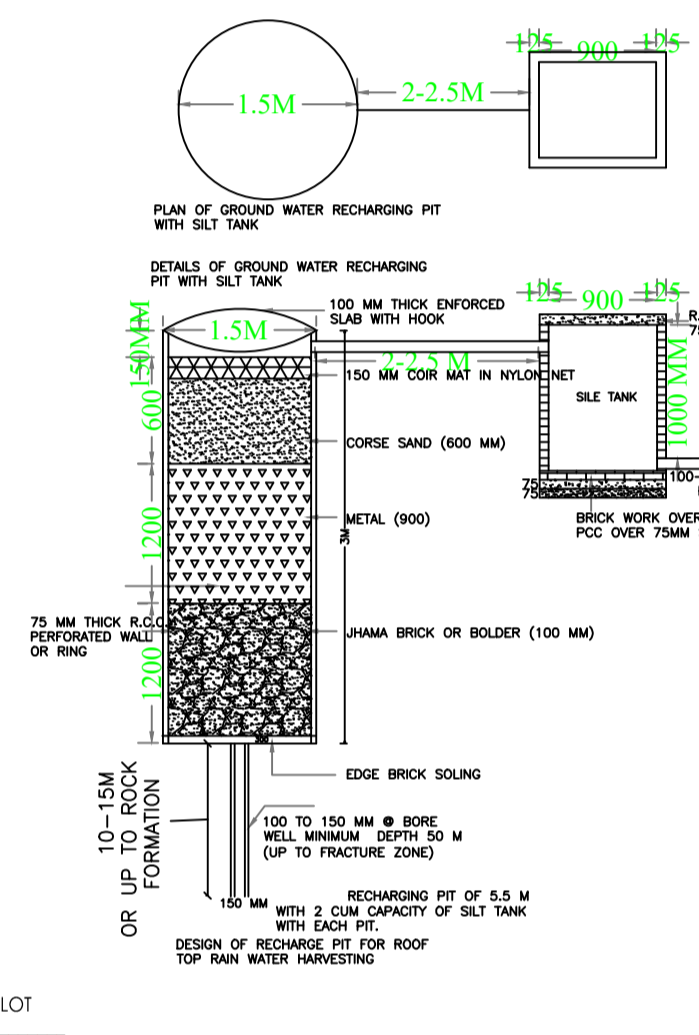
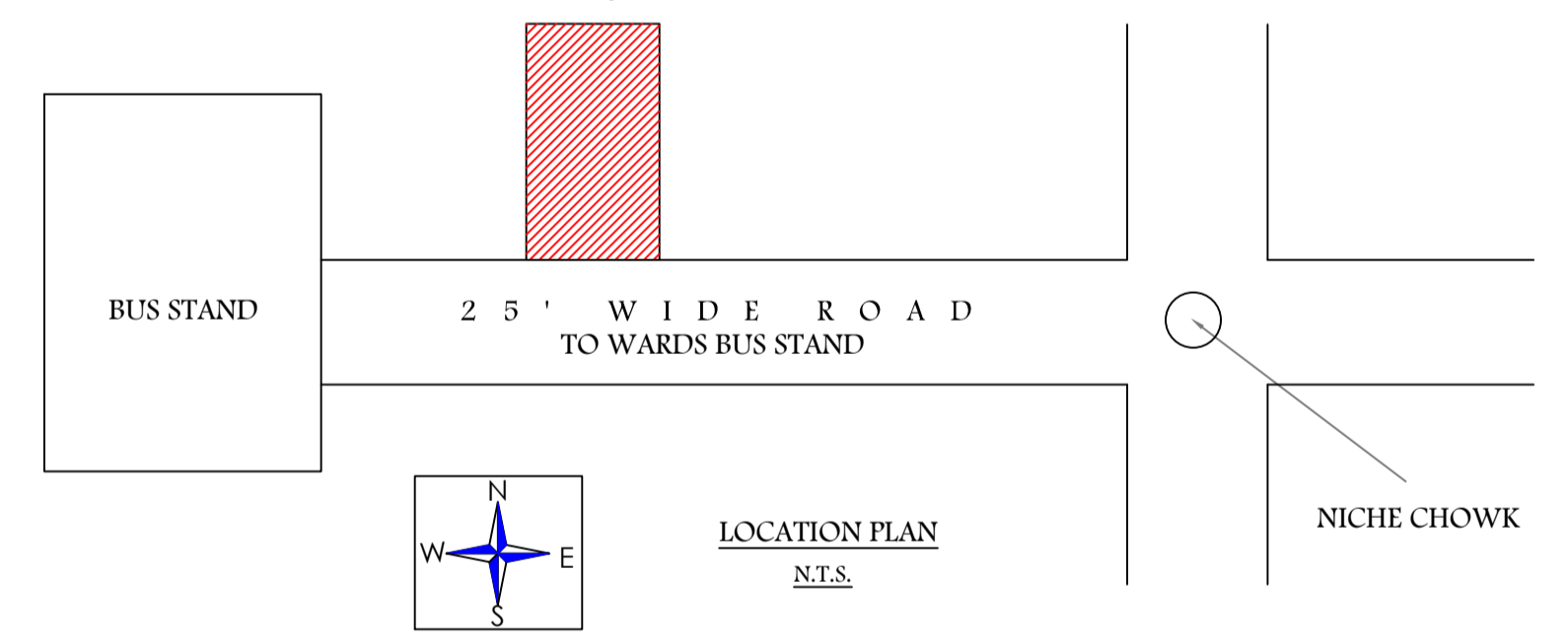
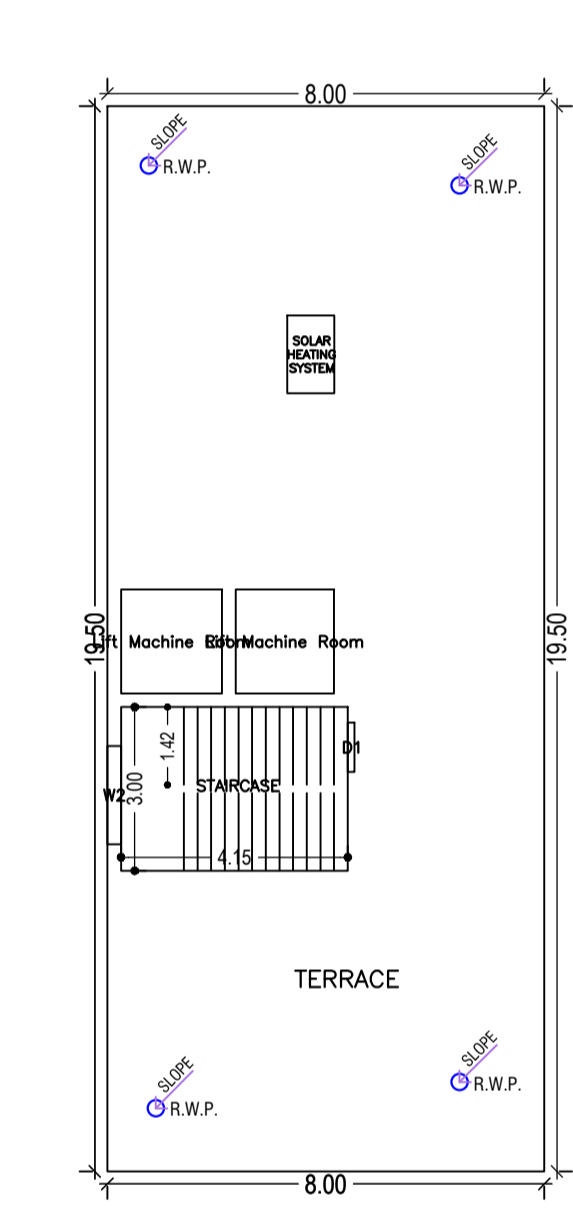
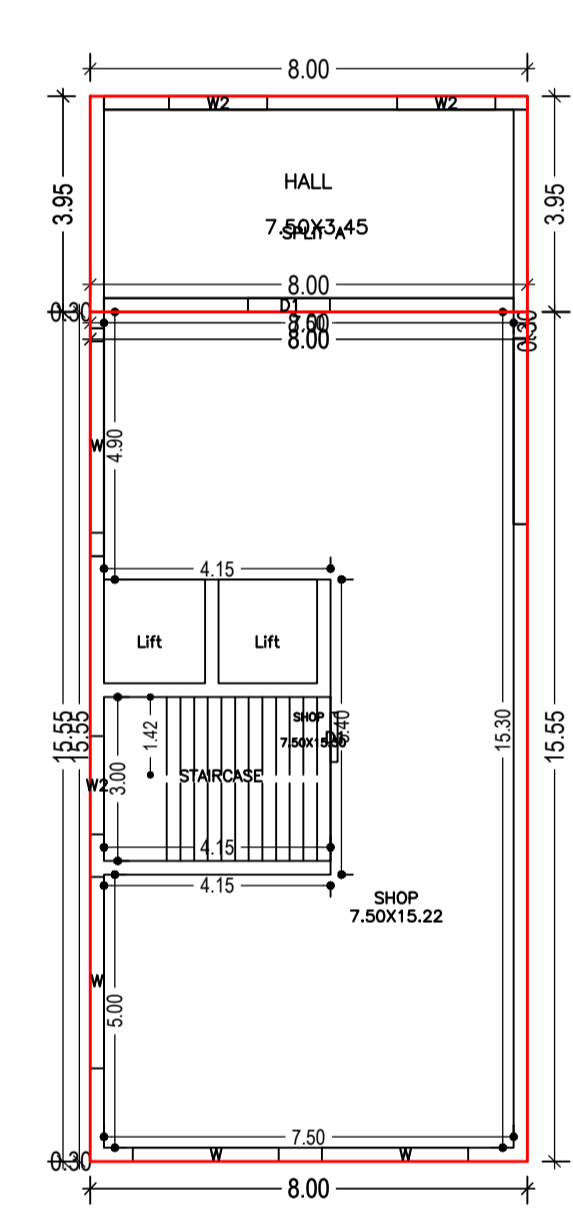
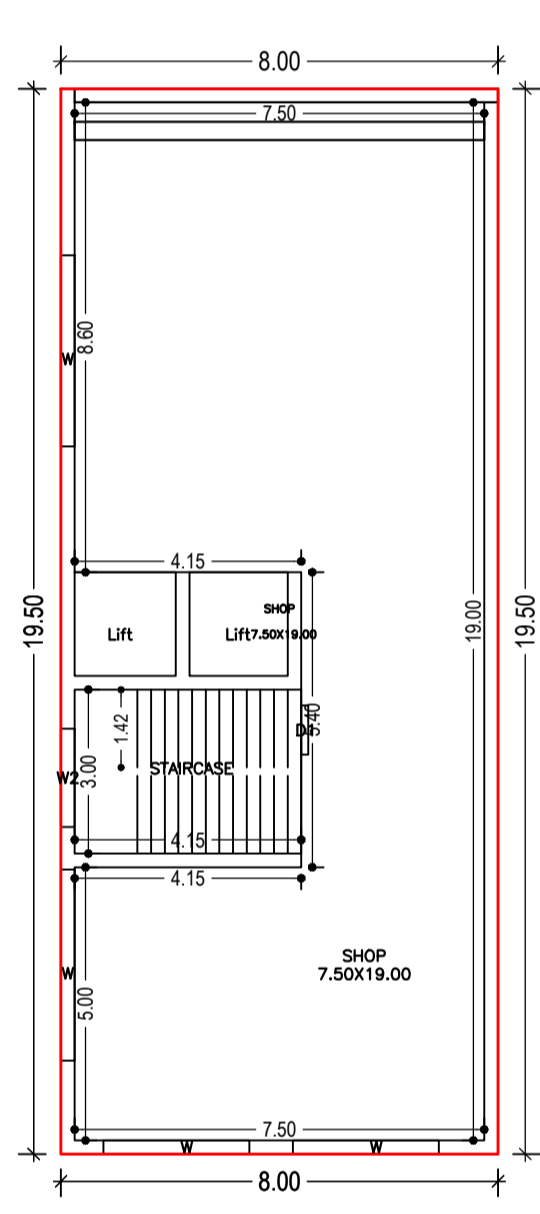
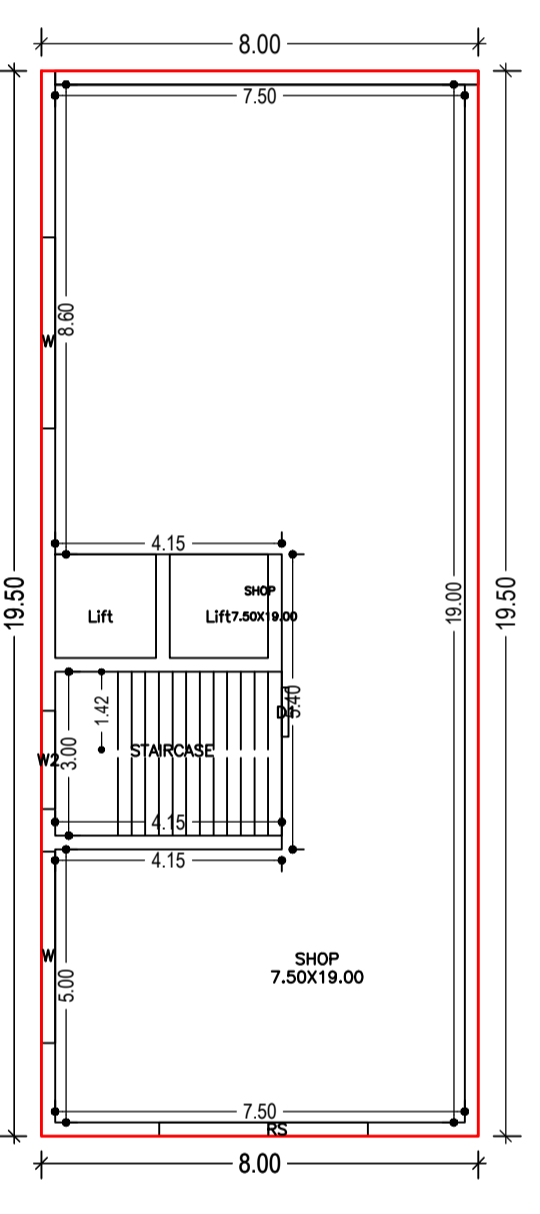
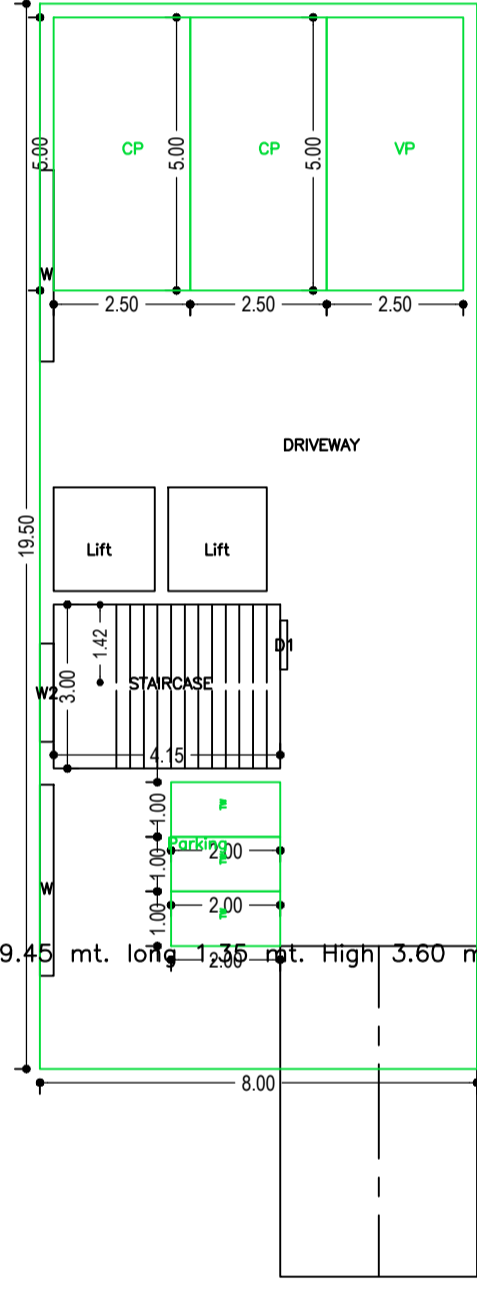
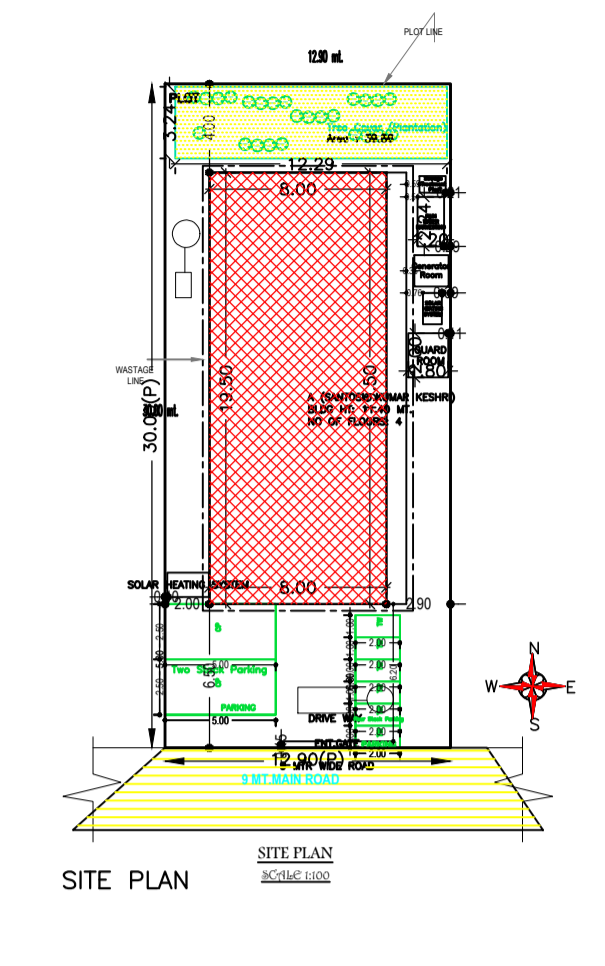
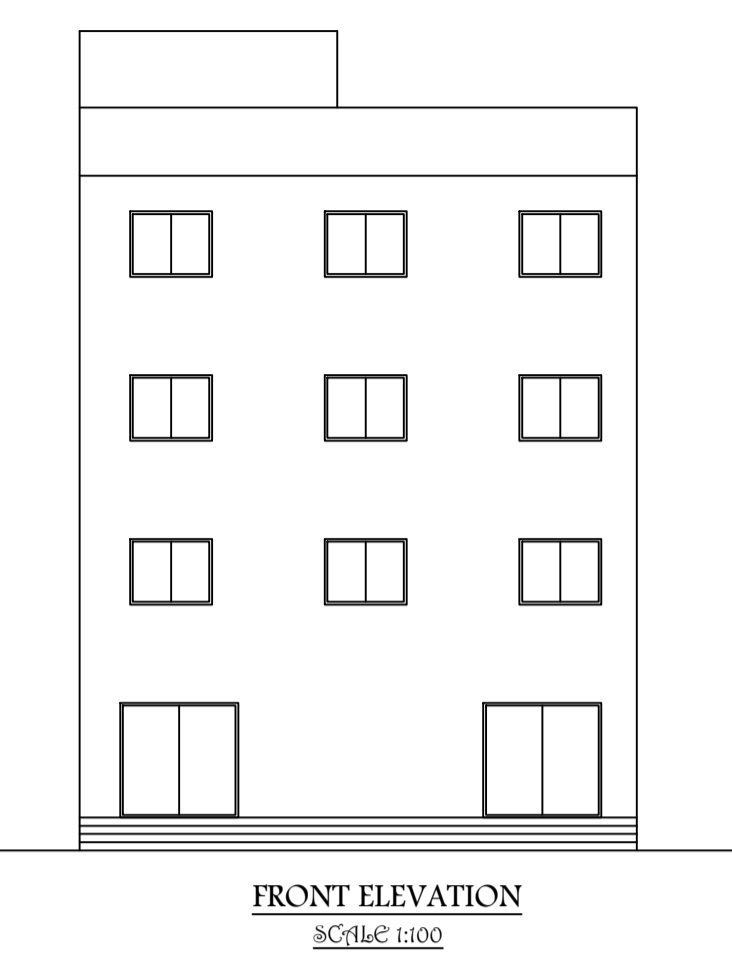
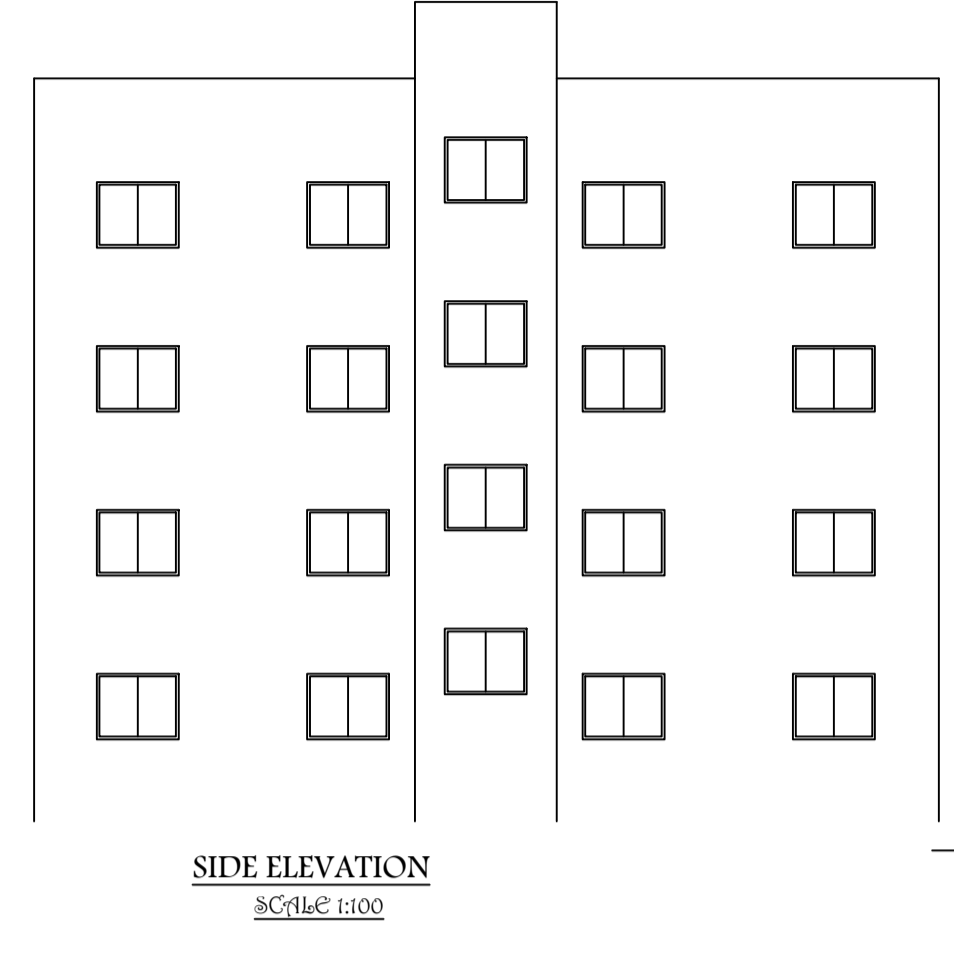
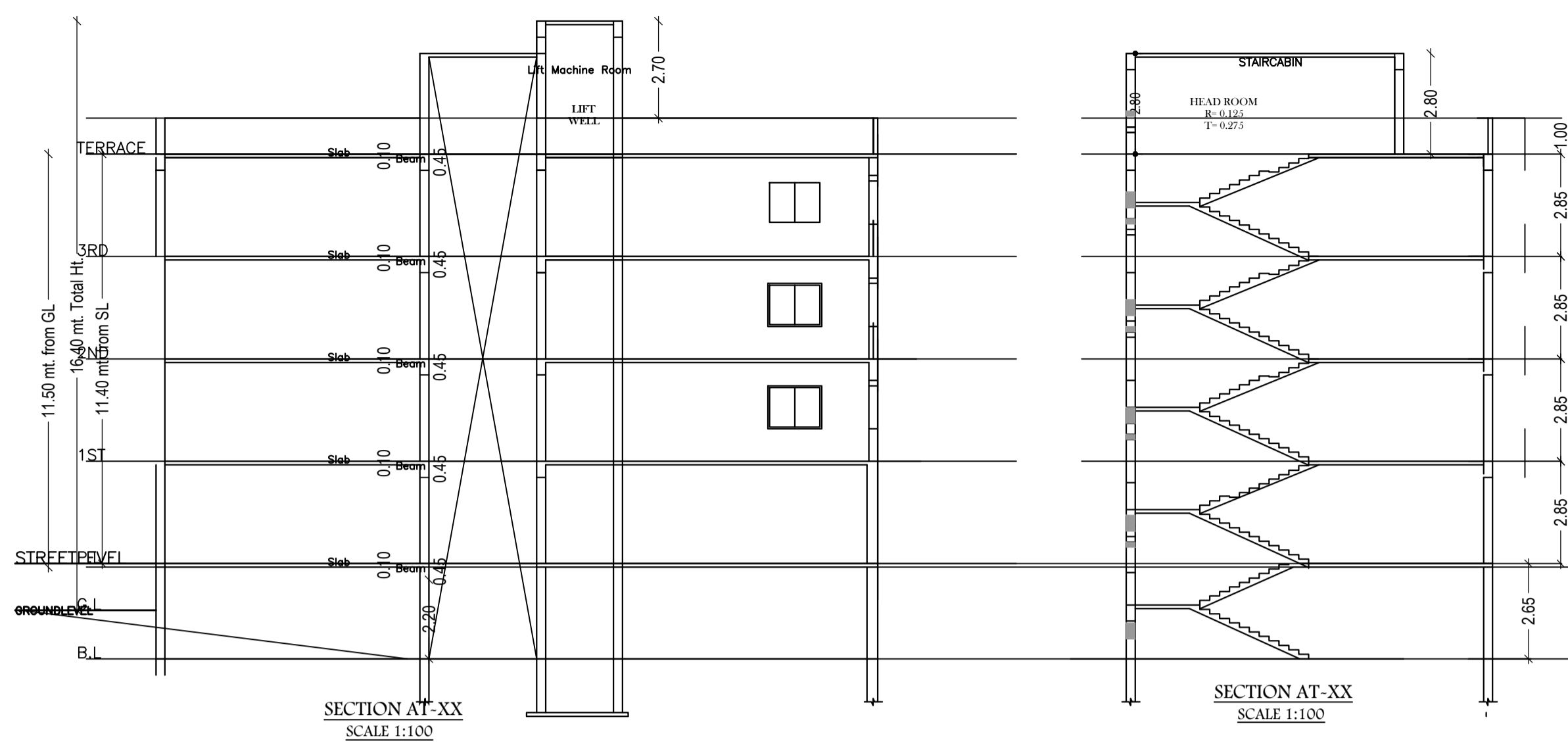

COLOR INDEX	
Plot Boundary	Black
Abutting Road	Red
Proposed Construction	Green
Common Plot	Yellow
Road Widening Area	Blue
Existing (To be retained)	Orange
Existing (To be demolished)	Grey

Floor Name	Building Name		Total	
	Proposed Built Up Area (Sq.mt)	Proposed FAR Area (Sq.mt)	Total Proposed Built Up Area (Sq.mt)	Total FAR Area (Sq.mt)
Basement Floor	156.00	12.45	156.00	12.45
Ground Floor	156.01	149.07	156.01	149.07
First Floor	156.01	149.07	156.01	149.07
Second Floor	156.01	149.07	156.01	149.07
Third Floor	156.01	149.07	156.01	149.07
Terrace Floor	0.00	0.00	0.00	0.00
Total	780.03	615.66	780.03	615.66

Floor Name	Total Built Up Area (Sq.mt)	Deductions (Area in Sq.mt)		Proposed FAR Area (Sq.mt)	Add Area in FAR (Sq.mt)	Total FAR Area (Sq.mt)	Total Consumed Additional FAR Area (Sq.mt)	Trmt (No.)
		Lift	Parking					
Basement Floor	156.00	6.94	138.62	0.00	0.00	12.45	12.45	12.45
Ground Floor	156.00	0.00	0.00	156.00	0.00	156.00	156.00	01
First Floor	156.01	6.94	0.00	149.07	0.00	149.07	149.07	01
Second Floor	156.01	6.94	0.00	149.07	0.00	149.07	149.07	01
Third Floor	156.01	6.94	0.00	149.07	117.47	149.07	149.07	02
Terrace Floor	0.00	0.00	0.00	0.00	0.00	0.00	0.00	00
Total	780.03	27.76	138.62	31.59	571.60	12.45	615.66	05

Building	No. of Same Bldg	Total Built Up Area (Sq.mt)	Deductions (Area in Sq.mt)		Proposed FAR Area (Sq.mt)	Add Area in FAR (Sq.mt)	Total FAR Area (Sq.mt)	Total Consumed Additional FAR Area (Sq.mt)	Trmt (No.)
			Lift	Parking					
A (SANTOSH KUMAR KESHRI)	1	780.03	27.76	138.62	31.59	571.60	12.45	615.66	05
Grand Total	1	780.03	27.76	138.62	31.59	571.60	12.45	615.66	05

Building Name	Type	SubUse	Area (Sq.mt)	Units	Car	Visitors Car	TwoWheeler
A (SANTOSH KUMAR KESHRI)	Commercial	Res/Comm Bldg	780.03	409.85	1	3	1
	Residential	Shop	50	105.02	1	2	1
	Residential	Residential Bldg/Apartment	1	1.00	1	1	1
	Residential	Residential Bldg/Apartment	1	1.00	1	1	1
Total				6	6	1	1

Vehicle Type	No.	Area	No.	Area
Car	6	75.00	6	75.00
Two Slack Car	2	25.00	2	25.00
Visitors Car Parking	1	12.50	1	12.50
Four Slack	15	30.00	15	30.00
TwoWheeler	1	14.00	1	14.00
Total TwoWheeler	15	30.00	22	44.00
Other Parking	-	-	-	95.12
Total	117.50	-	-	270.62

SCHEDULE OF DOOR:				
BUILDING NAME	NAME	LENGTH	HEIGHT	NOS
A (SANTOSH KUMAR KESHRI)	D1	0.90	2.10	04
A (SANTOSH KUMAR KESHRI)	D1	1.50	2.10	01
A (SANTOSH KUMAR KESHRI)	RS	3.82	2.50	01

SCHEDULE OF WINDOW/VENTILATION:				
BUILDING NAME	NAME	LENGTH	HEIGHT	NOS
A (SANTOSH KUMAR KESHRI)	W2	1.80	1.20	02
A (SANTOSH KUMAR KESHRI)	W2	1.80	2.50	06
A (SANTOSH KUMAR KESHRI)	W	2.67	2.50	06
A (SANTOSH KUMAR KESHRI)	W	3.50	2.50	08