

Proposal Basic Information

Proposal File No.	GUNPC/BP/0028/W01/2023
Owner Name	ASHOK RAM
Khata No	2
Plot No	117
Village Name	Dundurya
Use	Residential
SubUse	Bungalow/ Dwelling / Non Apartment

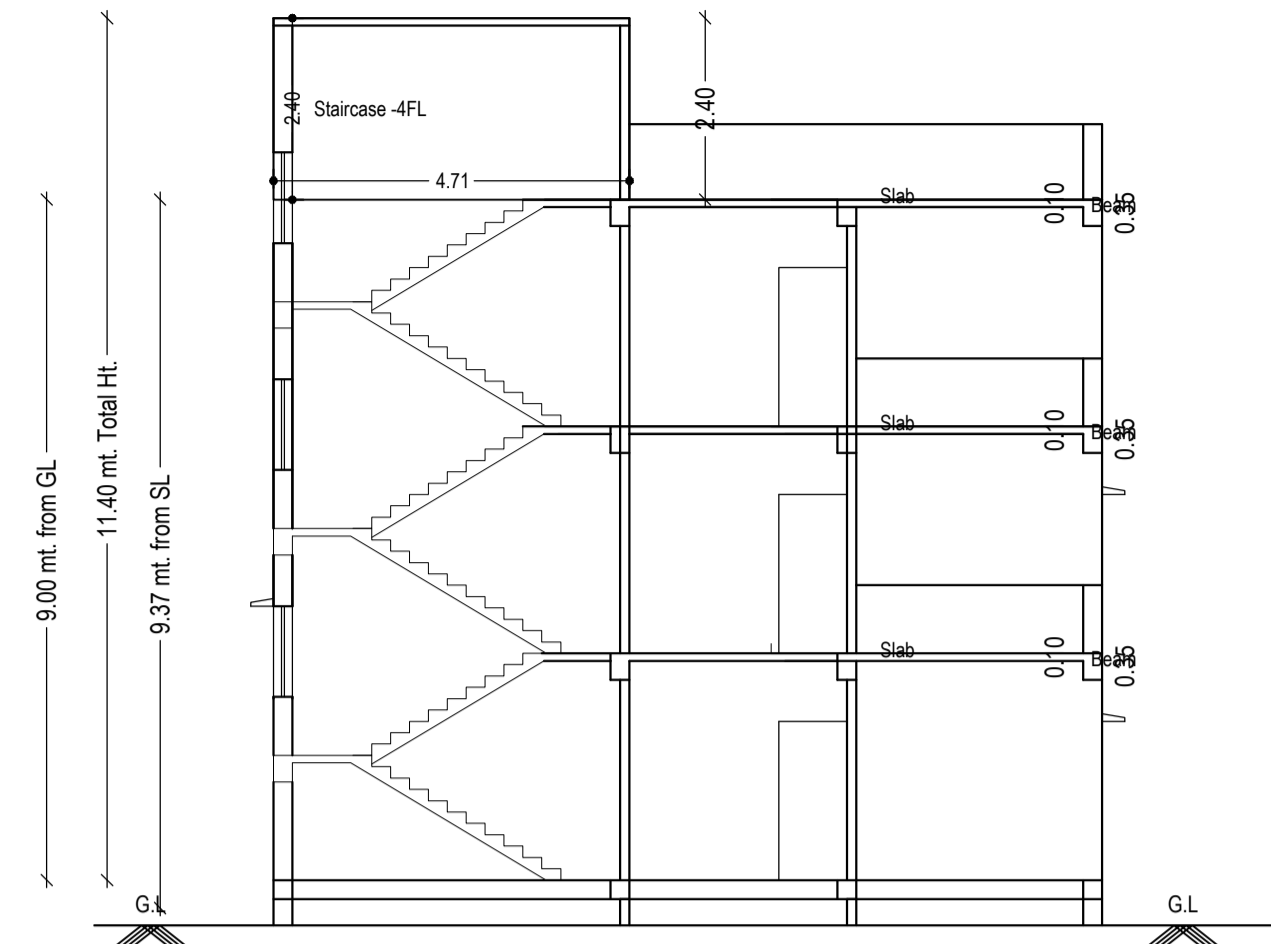

SECTION X-X
SCALE 1:100

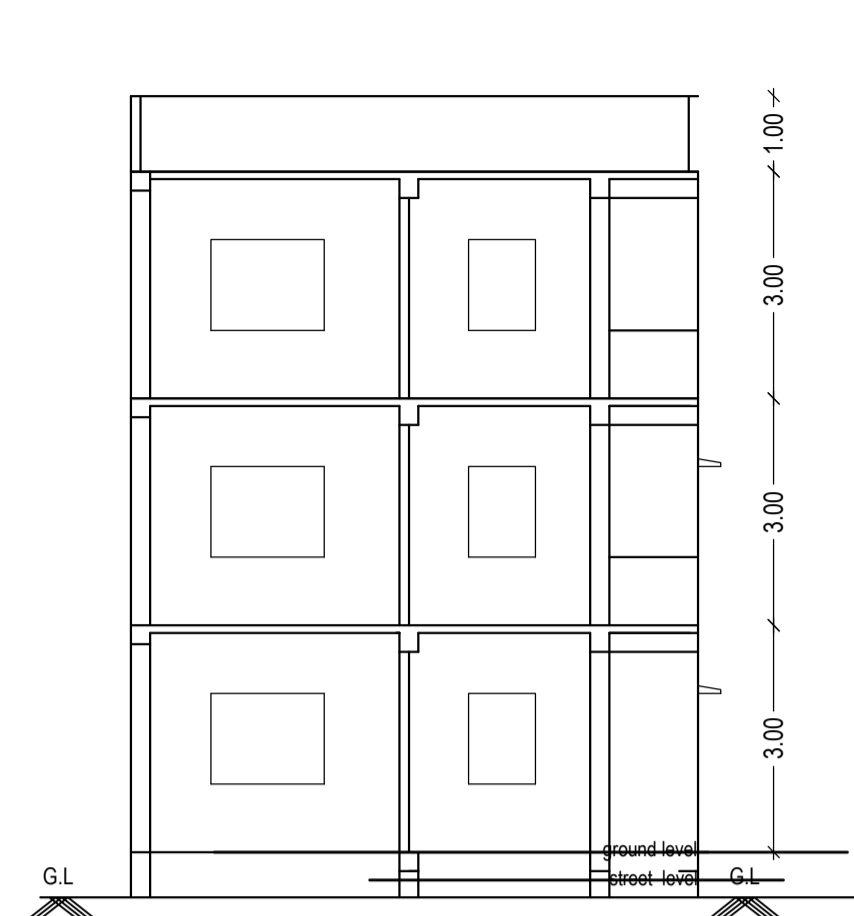

SECTION Y-Y
SCALE 1:100

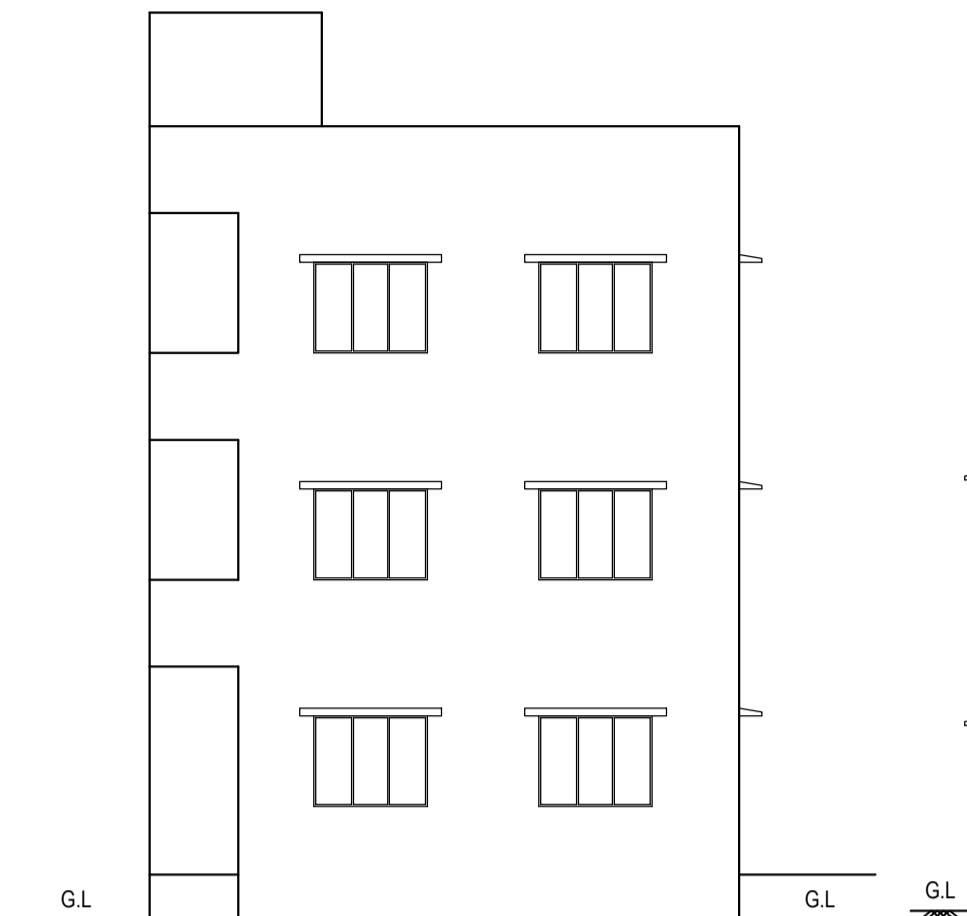

SIDE ELEVATION
SCALE 1:100

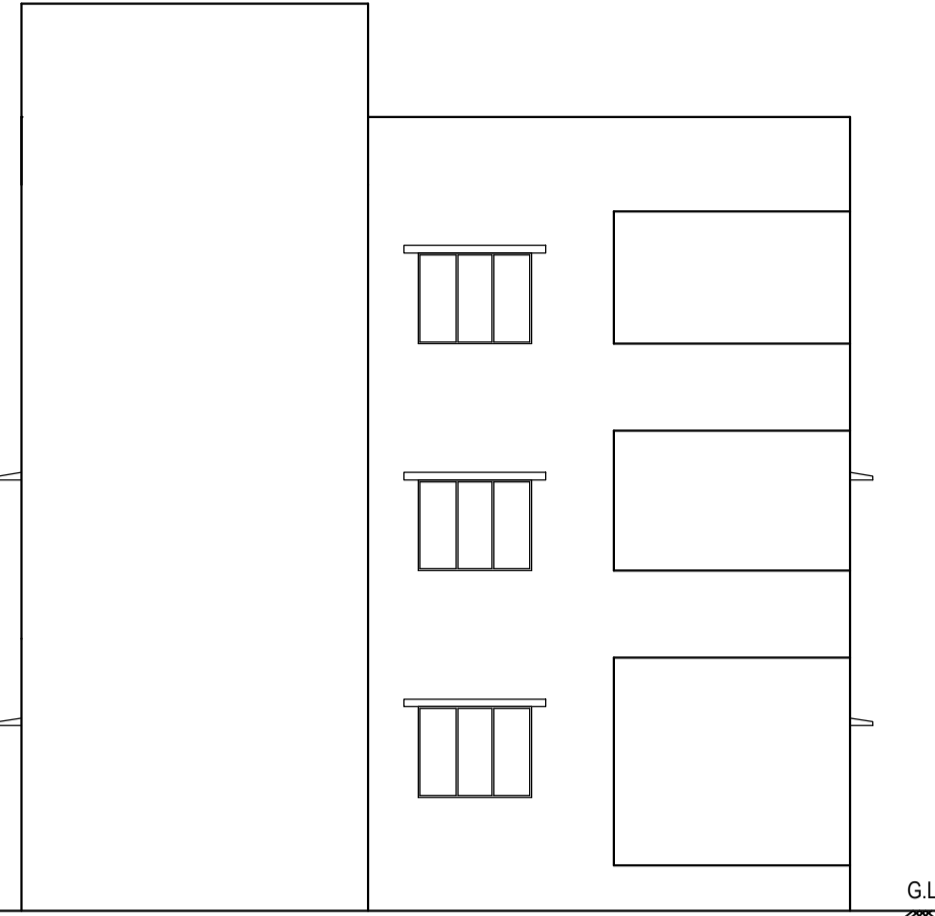

FRONT ELEVATION
SCALE 1:100

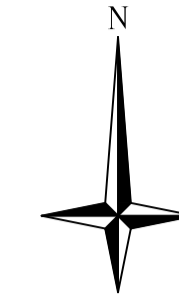
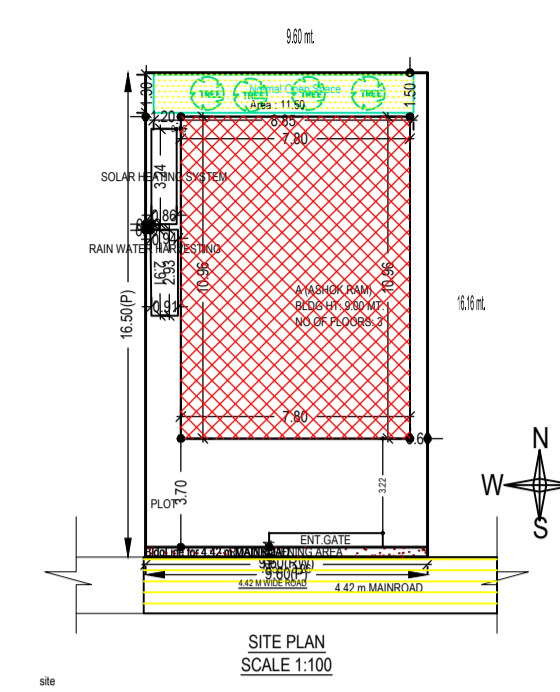

SCHEDULE OF DOOR:

BUILDING NAME	NAME	LENGTH	HEIGHT	NOS
A (ASHOK RAM)	d4	0.75	2.10	08
A (ASHOK RAM)	d5	0.93	2.10	03
A (ASHOK RAM)	d1	1.05	2.10	08

SCHEDULE OF WINDOW/VENTILATION:

BUILDING NAME	NAME	LENGTH	HEIGHT	NOS
A (ASHOK RAM)	v	0.60	0.60	05
A (ASHOK RAM)	w	1.50	1.20	08
A (ASHOK RAM)	w2	1.50	1.20	03
A (ASHOK RAM)	w	1.80	1.20	03

Building :A (ASHOK RAM)

Floor Name	Total Built Up Area (Sq.mt.)	Proposed FAR Area (Sq.mt.) Resi.	Total FAR Area (Sq.mt.)	Total Consumed Additional FAR Area (Sq.mt.)	Trmt (No.)
Ground Floor	85.49	85.49	85.49	85.49	01
First Floor	85.49	85.49	85.49	85.49	00
Second Floor	61.74	61.74	61.74	61.74	00
Terrace Floor	0.00	0.00	0.00	0.00	00
Total :	232.72	232.72	232.72	232.72	01
Total Number of Same Buildings :	1				
Total :	232.72	232.72	232.72	232.72	01

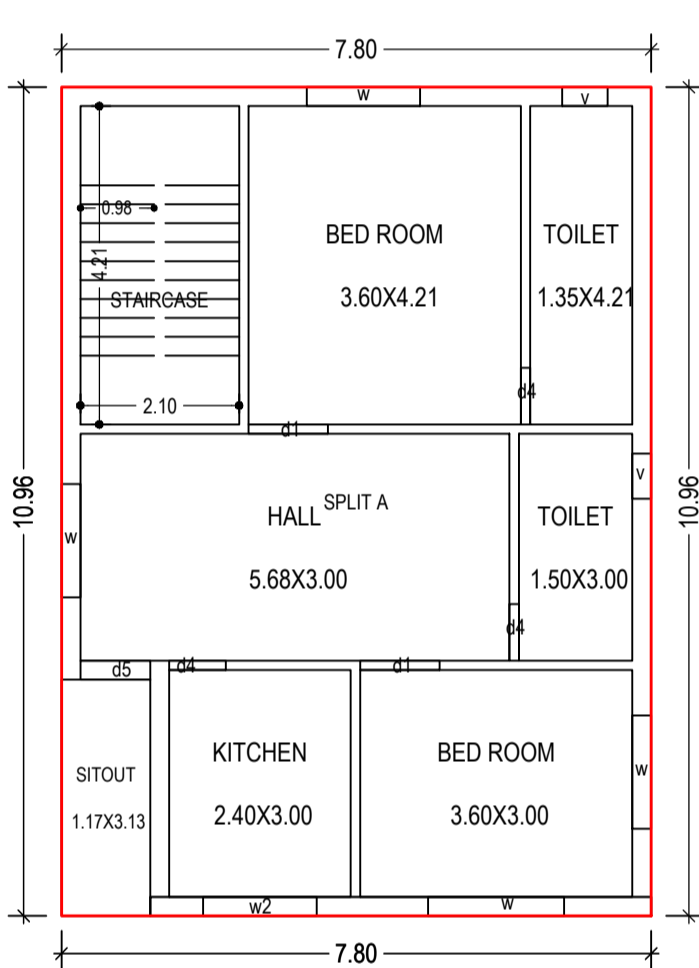

GROUND FLOOR PLAN
(Proposed)
SCALE 1:100

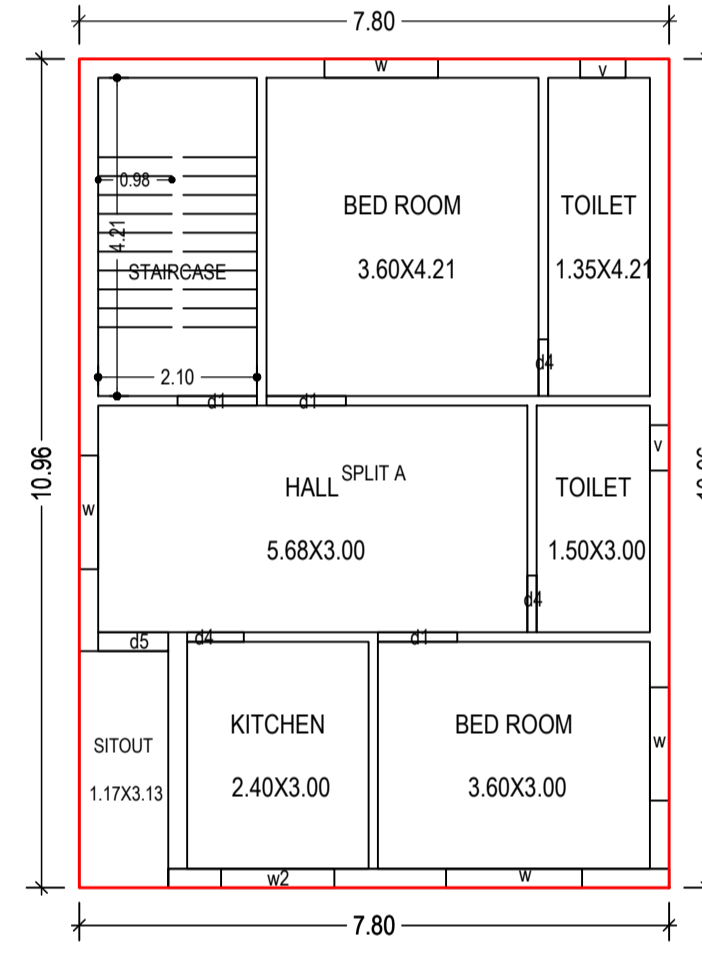

FIRST FLOOR PLAN
(Proposed)
SCALE 1:100

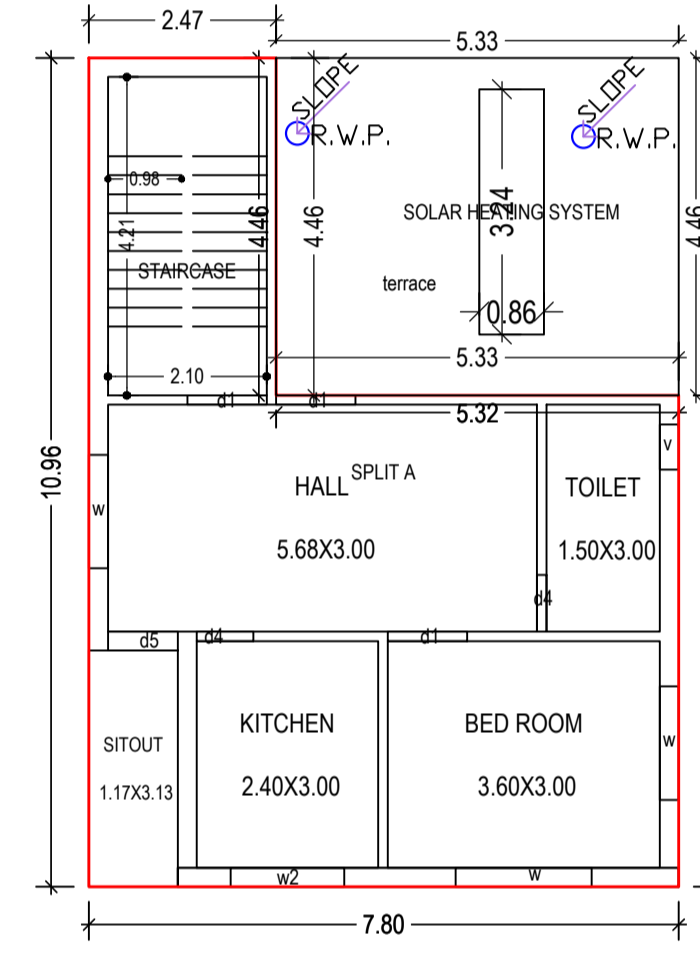

SECOND FLOOR PLAN
(Proposed)
SCALE 1:100

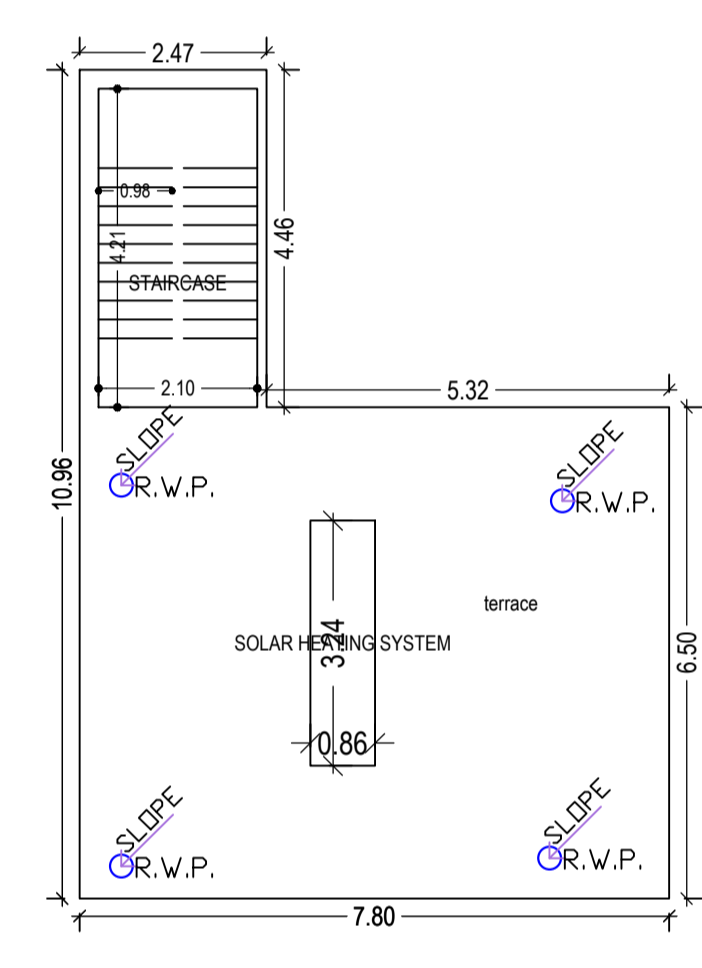

TERRACE FLOOR PLAN
(SCALE 1:100)

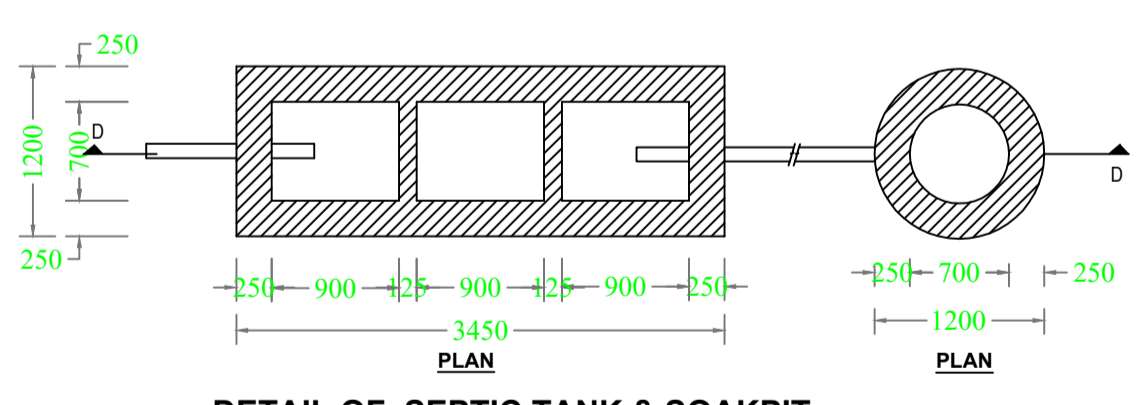
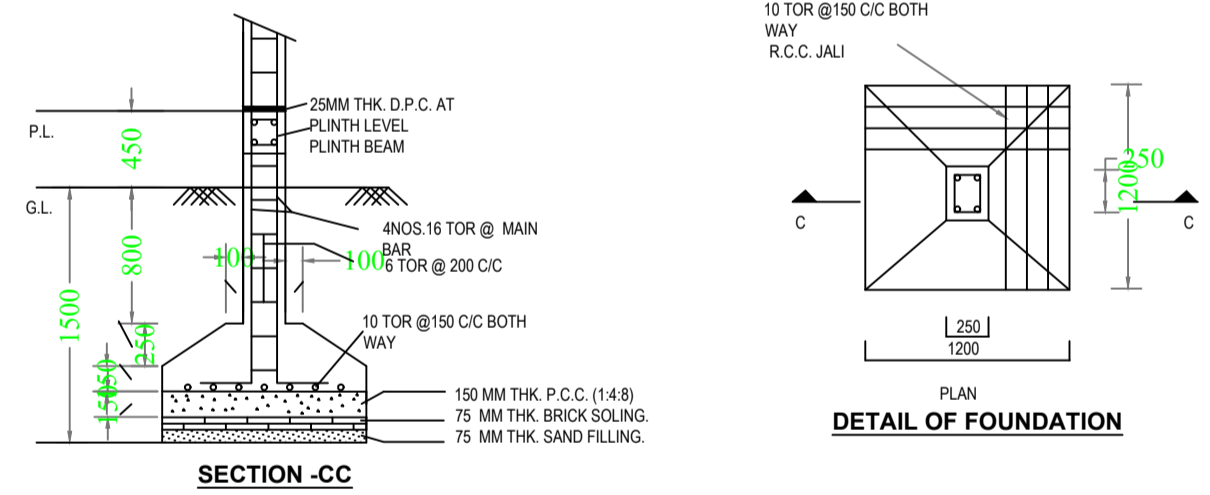
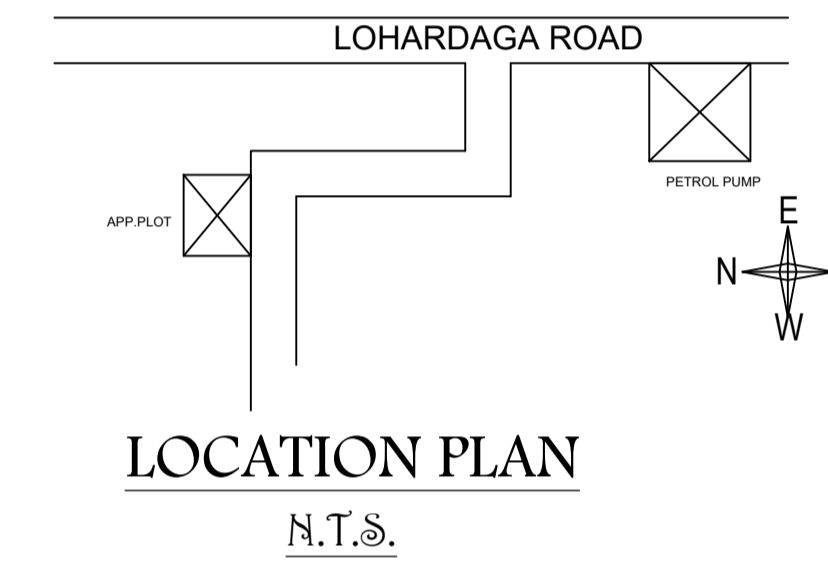

DETAIL OF SEPTIC TANK & SOAKPIT.

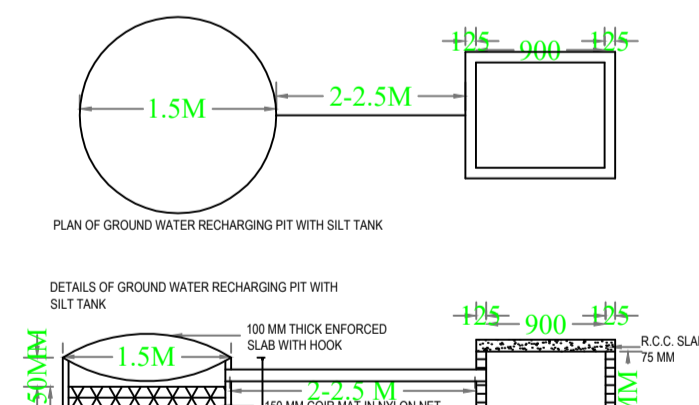

DETAIL OF GROUND WATER RECHARGING PIT WITH SALT TANK

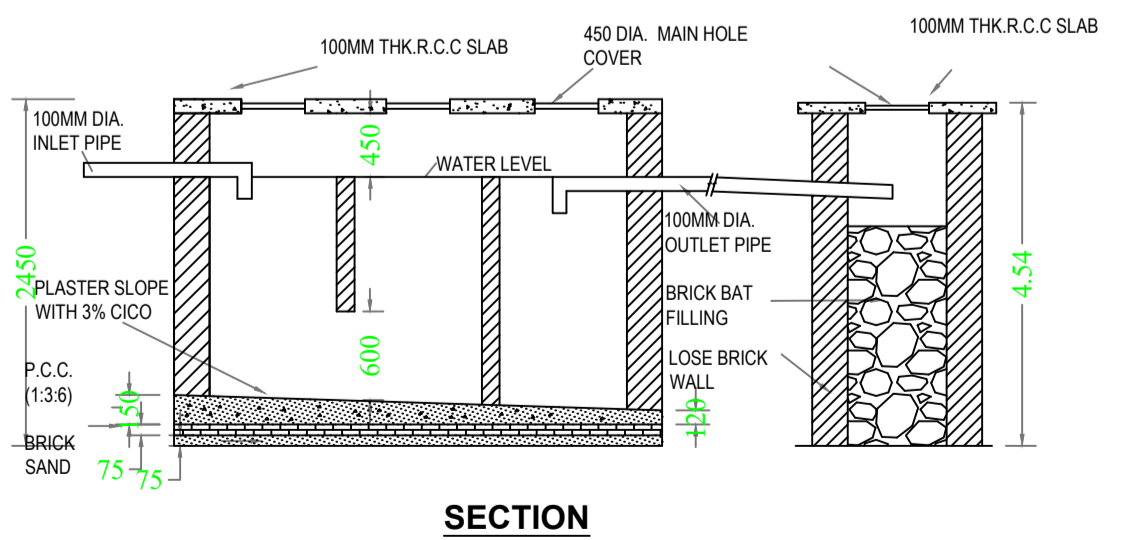

SECTION

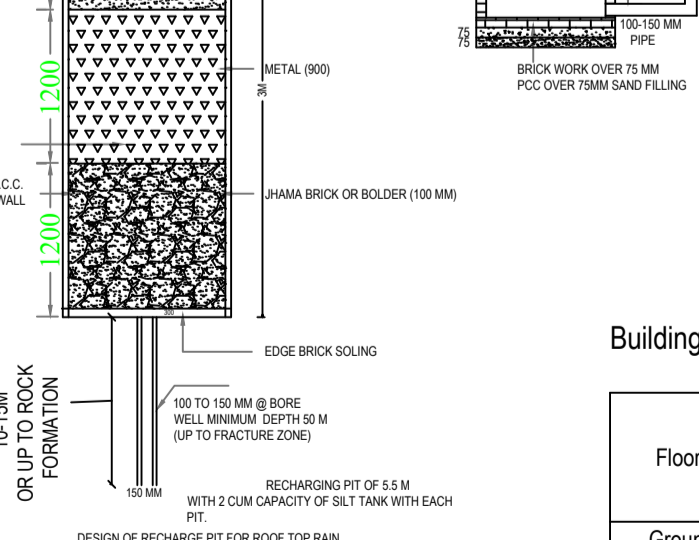

SECTION

Building USE/SUBUSE Details

Building Name	Building Use	Building SubUse	Building Structure
A (ASHOK RAM)	Residential	Bungalow/ Dwelling / Non Apartment	Non-Highrise

FAR & Tenement Details (Table 4c-1)

Building	No. of Same Bldg	Total Built Up Area (Sq.mt.)	Proposed FAR Area (Sq.mt.) Resi.	Total FAR Area (Sq.mt.)	Total Consumed Additional FAR Area (Sq.mt.)	Trmt (No.)
A (ASHOK RAM)	1	232.72	232.72	232.72	232.72	01
Grand Total :	1	232.72	232.72	232.72	232.72	01

Buildingwise Floor FAR Details

Floor Name	A (ASHOK RAM)		Total	
	Proposed Built Up Area (Sq.mt.)	Proposed FAR Area (Sq.mt.)	Total Proposed Built Up Area (Sq.mt.)	Total FAR Area (Sq.mt.)
Ground Floor	85.49	85.49	85.49	85.49
First Floor	85.49	85.49	85.49	85.49
Second Floor	61.74	61.74	61.74	61.74
Terrace Floor	0.00	0.00	0.00	0.00
Total :	232.72	232.72	232.72	232.72

UnitBUA Table for Building :A (ASHOK RAM)

FLOOR	Name	UnitBUA Type	UnitBUA Area	Carpel Area	No. of Rooms	No. of Tenement
GROUND FLOOR PLAN	SPLIT A	FLAT	232.71	227.75	7	1
FIRST FLOOR PLAN	SPLIT A	FLAT	0.00	0.00	7	0
SECOND FLOOR PLAN	SPLIT A	FLAT	0.00	0.00	5	0
Total :	-	-	232.71	227.75	19	1

COLOR INDEX

PLOT BOUNDARY	Black
ABUTTING ROAD	Red
PROPOSED CONSTRUCTION	Green
COMMON PLOT	Yellow
ROAD WIDENING AREA	Blue
EXISTING (To be retained)	Light Blue
EXISTING (To be demolished)	Dark Blue

AREA STATEMENT GUMLA NAGAR PARISHAD		VERSION NO.: 1.0.66
PROJECT DETAIL:		VERSION DATE: 16/10/2020
Region: JHARKHAND URBAN LOCAL BODIES	Plot Use: Residential	
District: GUMLA	Plot SubUse: Bungalow/ Dwelling / Non Apartment	
Authority: GUMLA NAGAR PARISHAD	PlotNearbyReligiousStructure: NA	
Inward No: GUNPC/BP/0028/W01/2023	Plot/SubPlot No: 117	
Application Type: General Proposal	North: -	
Project Type: Building Permission	South: -	
Nature of Development: New	East: -	
Location of Development Area: Old Area	West: -	
AREA DETAILS:		SQ.MT.
AREA OF PLOT (Minimum)	(A)	158.40
Deduction for NetPlot Area		
Road Widening Area		3.26
Total		3.26
NET AREA OF PLOT(Gross Plot Area - Deduction from Gross Plot area)	(A-Deductions)	155.14
Deduction for Balance Plot Area(from Gross Plot Area)		
Road Widening Area		3.26
Common Plot		11.50
Total		14.76
BALANCE AREA OF PLOT(Net Plot Area - Recreational/Amenity space)	(A-Deductions)	143.64
PLOT AREA FOR COVERAGE(Net Plot Area)	(A-Deductions)	155.14
Plot Area for FAR (Net Plot Area + RoadWidening Area)	(A-Deductions)	155.14
COVERAGE CHECK		
Permissible Coverage area (70.00 %)		108.60
Proposed Coverage Area (55.11 %)		85.49
Total Prop. Coverage Area (55.11 %)		85.49
Balance coverage area (14.90 %)		23.11
FAR CHECK		
Perm. FAR Area (1.500)		232.71
Total Perm. FAR area		232.71
Residential FAR		232.71
Proposed FAR		232.71
Total Proposed FAR Area		232.71
Consumed FAR (Factor)		1.50
Balance FAR Area		0.00
BUILT UP AREA CHECK		
Total Proposed BuiltUp Area		232.72
ARCHITECT (Regd)	DEEPAK DIWAN	
ENGINEER (Regd)		
SUPERVISOR (Regd)		
OWNER (Regd)	ASHOK RAM	
DEVELOPMENT AUTHORITY	LOCAL BODY	

LTP NAME AND SIGNATURE	STRUCTURAL ENG'S NAME AND SIGNATURE	BUILDER NAME AND SIGNATURE	DIGITAL SIGNATURE
DEEPAK DIWAN GUNPC/ARC/0003/2017			