

SECTION X-X

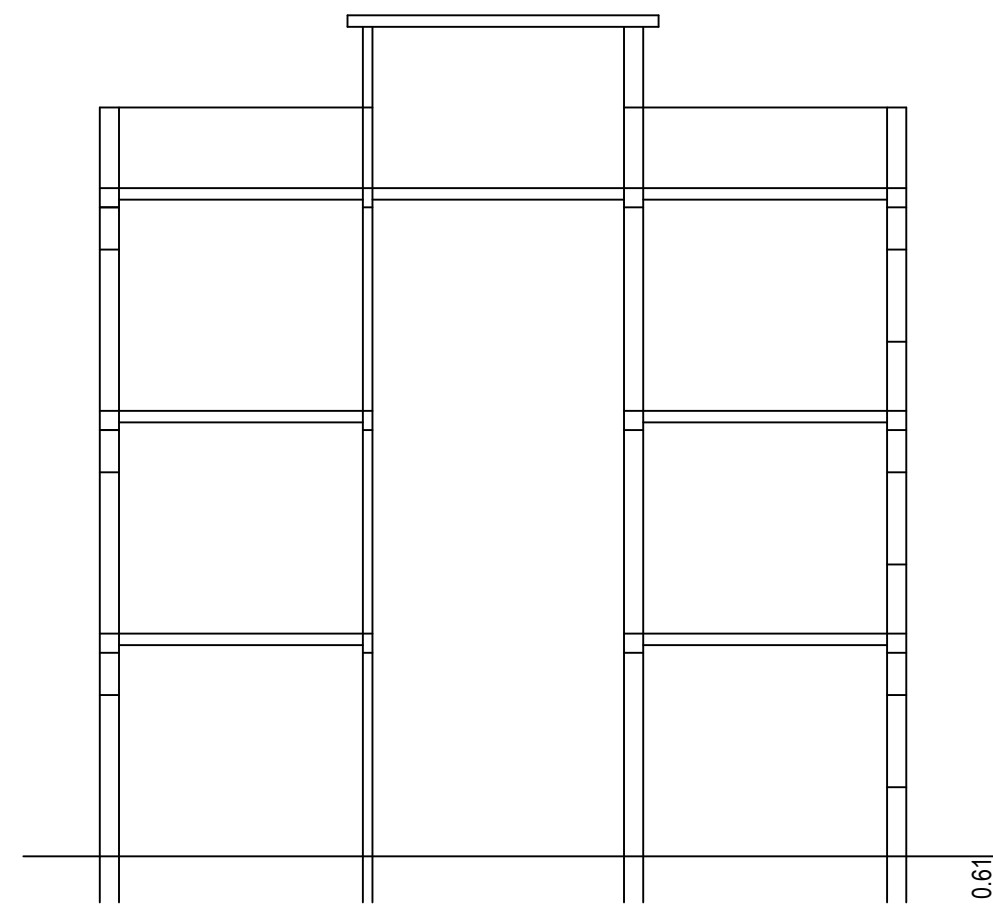

SECTION Y-Y

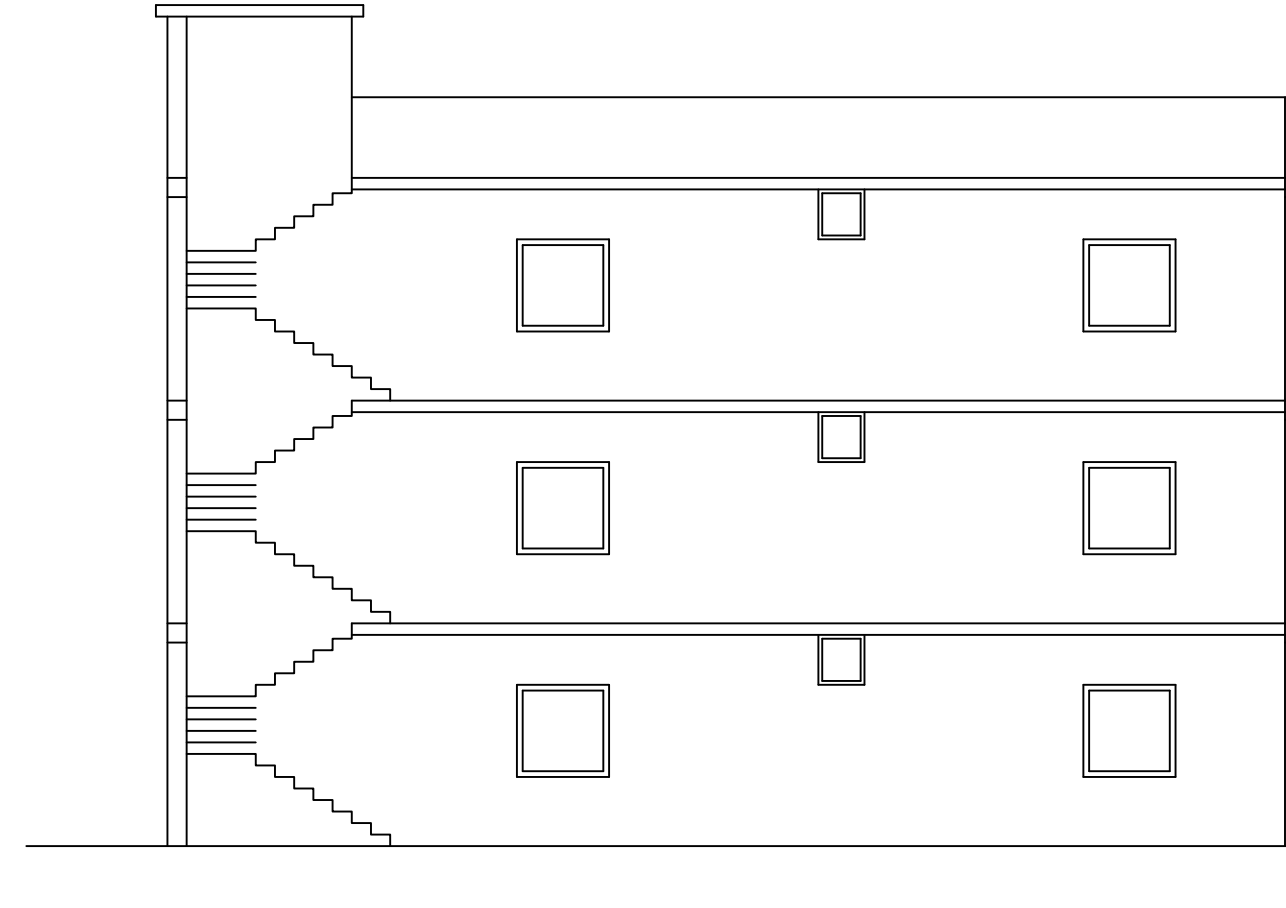

ELEVATION SIDE

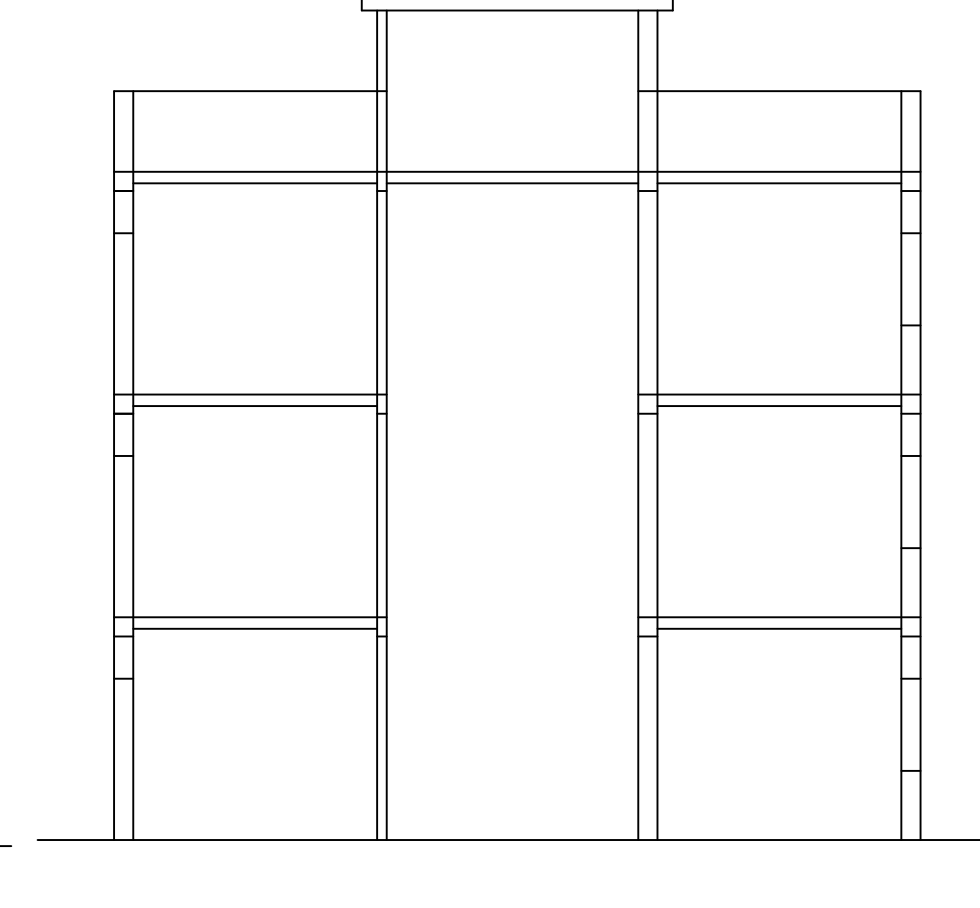

ELEVATION FRONT

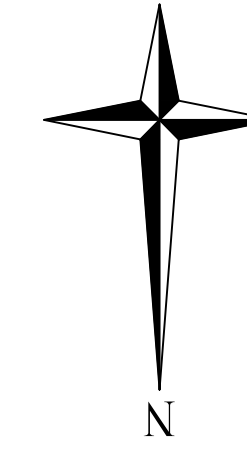

Proposal Basic Information	
Proposal File No.	GUNPC/BP/0067/W02/2023
Owner Name	ARCHANA KUMARI
Khata No	2
Plot No	393
Village Name	Dundurya
Use	Residential
SubUse	Bungalow/ Dwelling / Non Apartment

COLOR INDEX	
PLOT BOUNDARY	Black
ABUTTING ROAD	Green
PROPOSED CONSTRUCTION	Red
COMMON PLOT	Yellow
ROAD WIDENING AREA	Blue
EXISTING (To be retained)	Light Blue
EXISTING (To be demolished)	Dark Blue

Building :ARCHANA KUMARI (A BUILDING)

Floor Name	Total Built Up Area (Sq.mt.)	Proposed FAR Area (Sq.mt.)	Total FAR Area (Sq.mt.)	Total Consumed Additional FAR Area (Sq.mt.)	Trmt (No.)
Ground Floor	141.96	141.96	141.96	141.96	01
First Floor	137.90	137.90	137.90	137.90	00
Second Floor	138.28	138.28	138.28	138.28	00
Terrace Floor	0.00	0.00	0.00	0.00	00
Total :	418.14	418.14	418.14	418.14	01
Total Number of Same Buildings :	1				
Total :	418.14	418.14	418.14	418.14	01

SCHEDULE OF DOOR:

BUILDING NAME	NAME	LENGTH	HEIGHT	NOS
ARCHANA KUMARI (A BUILDING)	D2	0.69	2.10	03
ARCHANA KUMARI (A BUILDING)	D1	0.76	2.10	03
ARCHANA KUMARI (A BUILDING)	D3	0.76	2.10	03
ARCHANA KUMARI (A BUILDING)	D1	0.85	2.10	03
ARCHANA KUMARI (A BUILDING)	D	0.91	2.10	18
ARCHANA KUMARI (A BUILDING)	FD	1.00	2.10	02

SCHEDULE OF WINDOW/VENTILATION:

BUILDING NAME	NAME	LENGTH	HEIGHT	NOS
ARCHANA KUMARI (A BUILDING)	V	0.60	1.20	09
ARCHANA KUMARI (A BUILDING)	W	1.22	1.20	18
ARCHANA KUMARI (A BUILDING)	W	1.50	1.20	01
ARCHANA KUMARI (A BUILDING)	W	1.52	1.20	01
ARCHANA KUMARI (A BUILDING)	W	1.59	1.20	01

Buildingwise Floor FAR Details

Floor Name	Building Name		Total	
	ARCHANA KUMARI (A BUILDING)	Proposed Built Up Area (Sq.mt.)	Proposed FAR Area (Sq.mt.)	Total Proposed Built Up Area (Sq.mt.)
Ground Floor	141.96	141.96	141.96	141.96
First Floor	137.90	137.90	137.90	137.90
Second Floor	138.28	138.28	138.28	138.28
Terrace Floor	0.00	0.00	0.00	0.00
Total :	418.14	418.14	418.14	418.14

AREA STATEMENT GUMLA NAGAR PARISHAD		VERSION NO. : 1.0.66
PROJECT DETAIL:		VERSION DATE: 16/10/2020
Region : JHARKHAND URBAN LOCAL BODIES	Plot Use: Residential	
District: GUMLA	Plot SubUse: Bungalow/ Dwelling / Non Apartment	
Authority: GUMLA NAGAR PARISHAD	Plot/Nearby/Religious/Structure: NA	
Inward No: GUNPC/BP/0067/W02/2023	Plot/SubPlot No: 393	
Application Type: General Proposal	North: -	
Project Type: Building Permission	South: -	
Nature of Development: New	East: -	
Location of Development Area: Old Area	West: -	
AREA DETAILS:		SQ.MT.
AREA OF PLOT (Minimum)	(A)	284.55
Deduction for NetPlot Area		
Surrender Free of Cost		11.81
Total		11.81
NET AREA OF PLOT(Gross Plot Area - Deduction from Gross Plot Area)	(A-Deductions)	272.74
Deduction for Balance Plot Area(from Gross Plot Area)		
Surrender Free of Cost		11.81
Common Plot		42.02
Total		53.83
BALANCE AREA OF PLOT(Net Plot Area - Recreational/Amenity space)	(A-Deductions)	230.72
PLOT AREA FOR COVERAGE(Net Plot Area)	(A-Deductions)	272.74
Plot Area for FAR (Net Plot Area + Road/Widening Area)	(A-Deductions)	284.55
COVERAGE CHECK		
Permissible Coverage area (60.00 %)		163.64
Proposed Coverage Area (52.05 %)		141.96
Total Prop. Coverage Area (52.05 %)		141.96
Balance coverage area (7.95 %)		21.68
FAR CHECK		
Perm. FAR Area (1.500)		426.82
Total Perm. FAR area		426.82
Residential FAR		418.14
Proposed FAR Area		418.14
Total Proposed FAR Area		418.14
Consumed FAR (Factor)		1.47
Balance FAR Area		8.68
BUILT UP AREA CHECK		
Total Proposed BuiltUp Area		418.14
ARCHITECT (Regd)	RAWNIT KUMAR	
ENGINEER (Regd)		
SUPERVISOR (Regd)		
OWNER (Regd)	ARCHANA KUMARI	
DEVELOPMENT AUTHORITY		LOCAL BODY

UnitBUA Table for Building :ARCHANA KUMARI (A BUILDING)

FLOOR	Name	UnitBUA Type	UnitBUA Area	Carpet Area	No. of Rooms	No. of Tenement
GROUND FLOOR PLAN	SPLIT A	FLAT	357.07	356.94	12	1
FIRST FLOOR PLAN	SPLIT A	FLAT	0.00	0.00	11	0
SECOND FLOOR PLAN	SPLIT A	FLAT	0.00	0.00	11	0
Total:	-	-	357.07	356.94	34	1

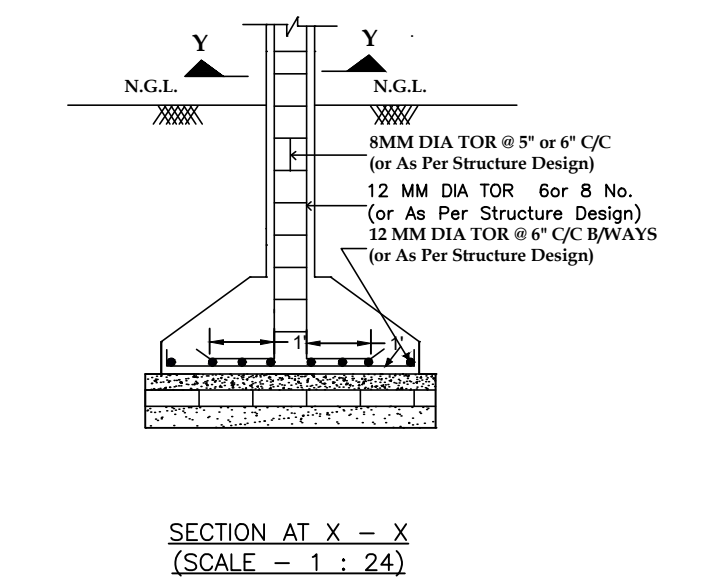
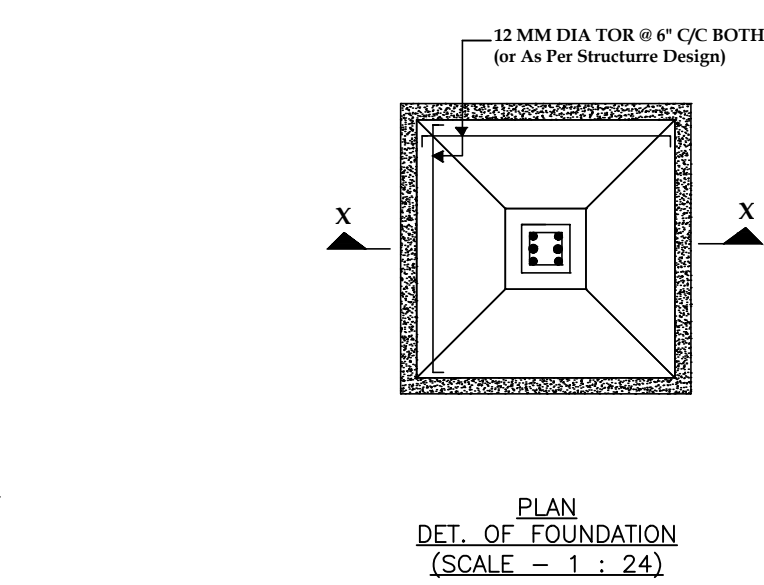
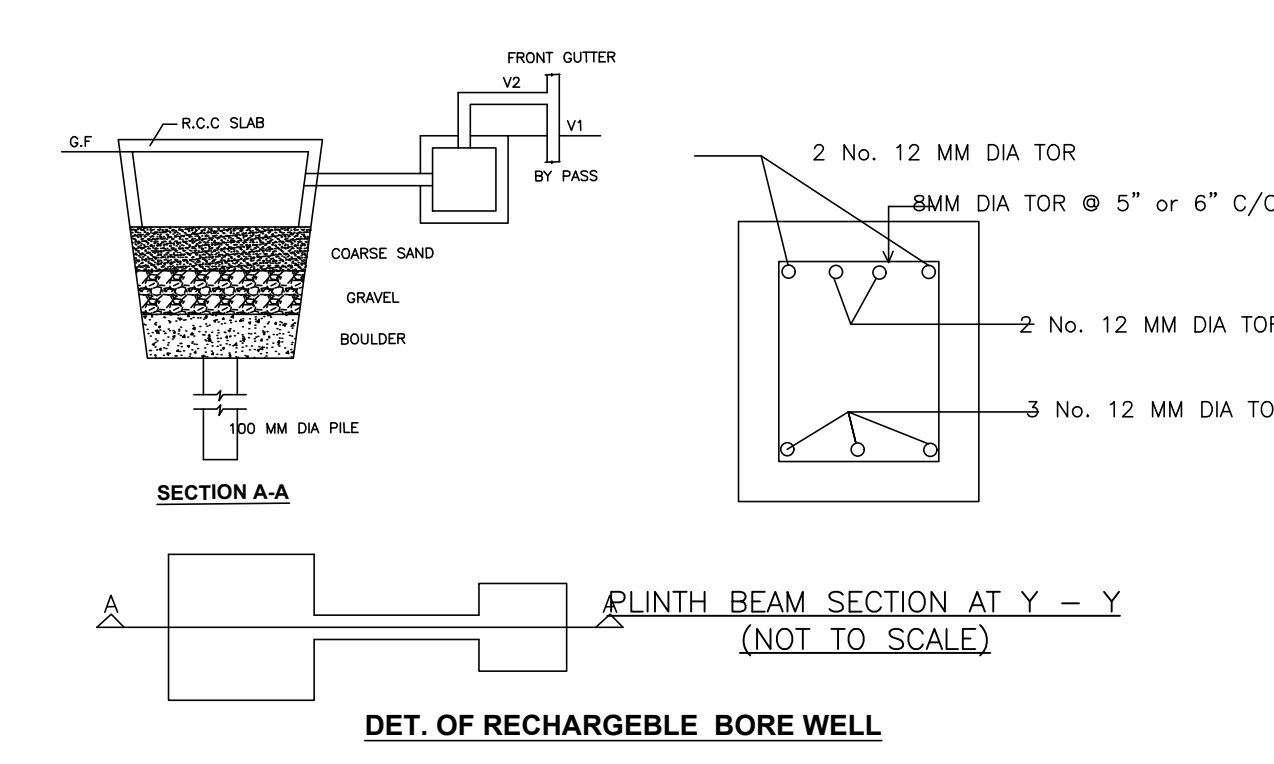
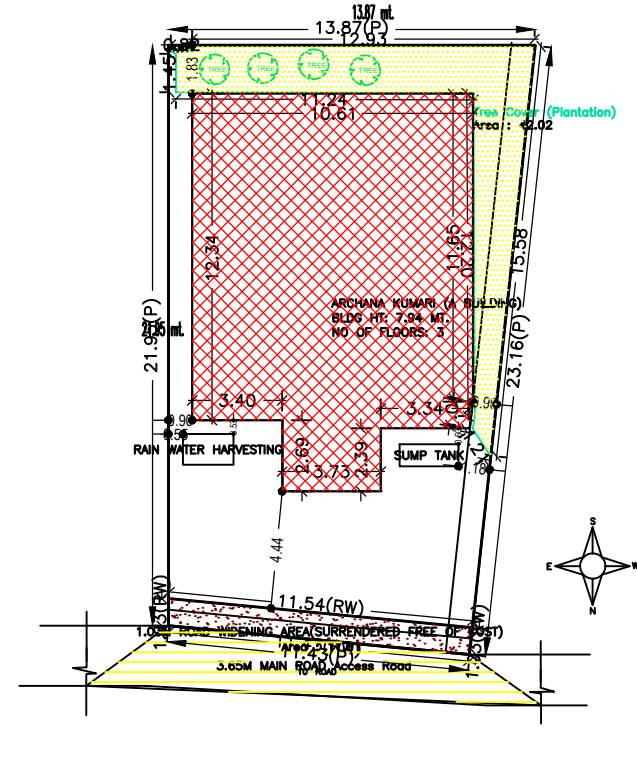
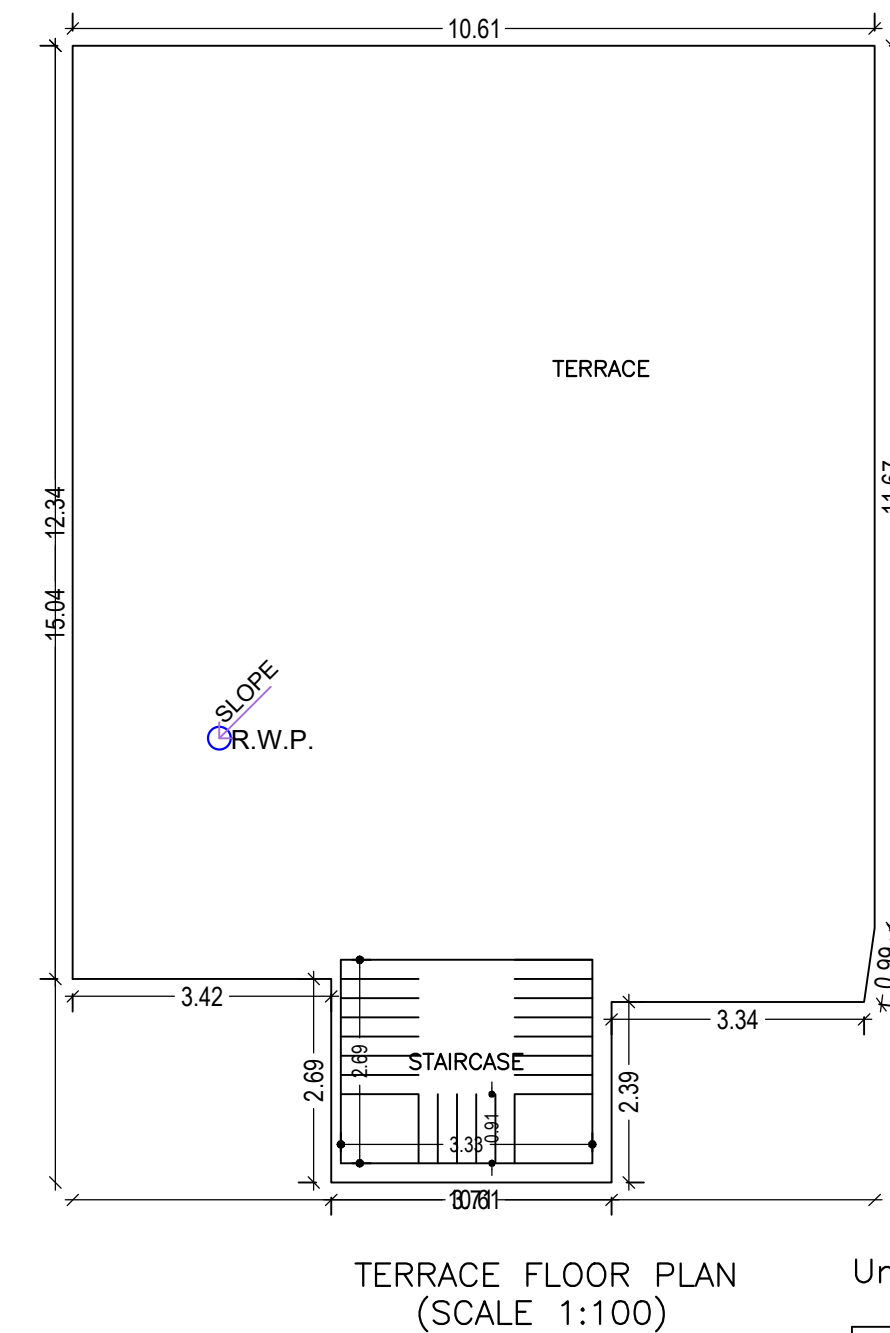
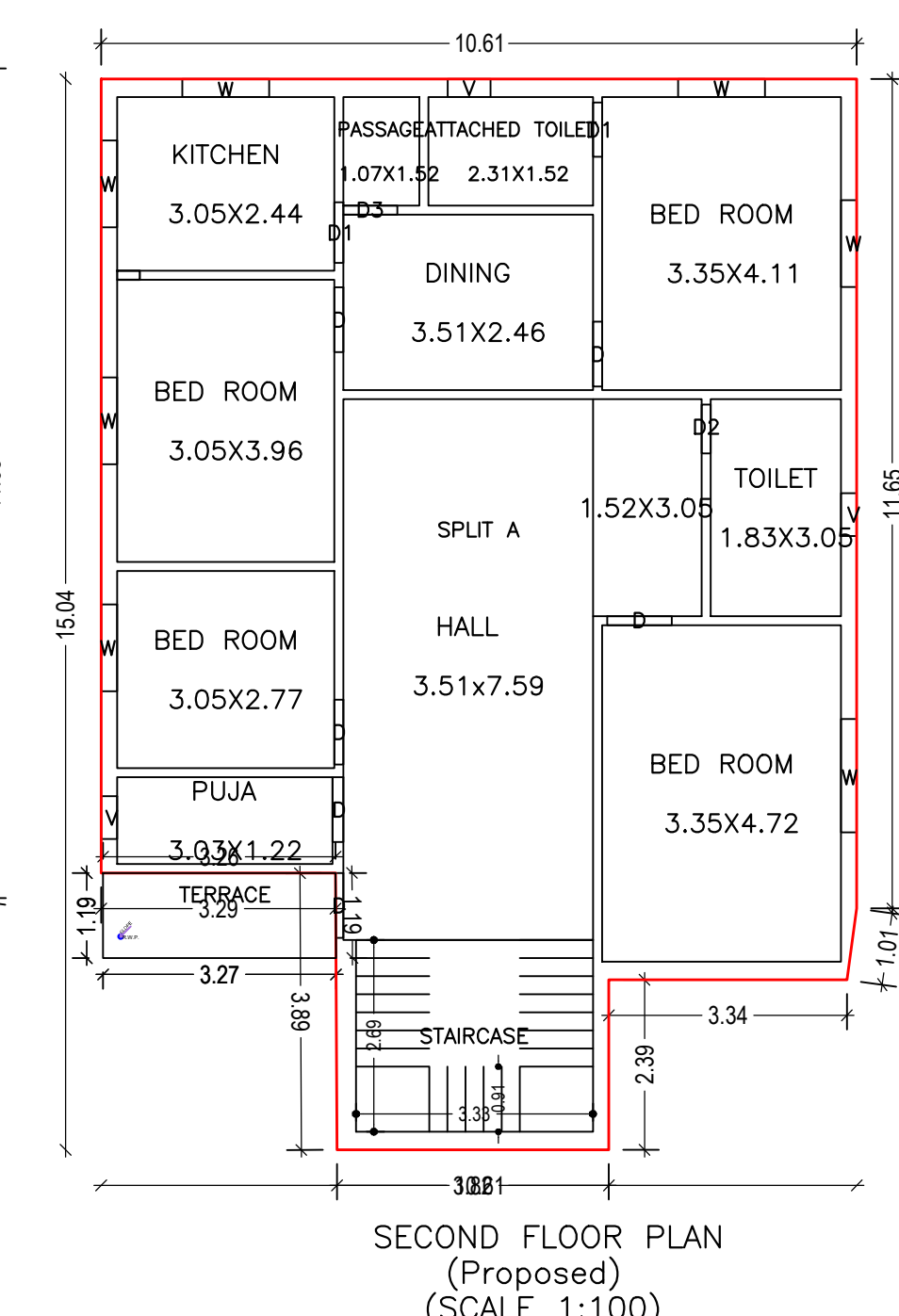
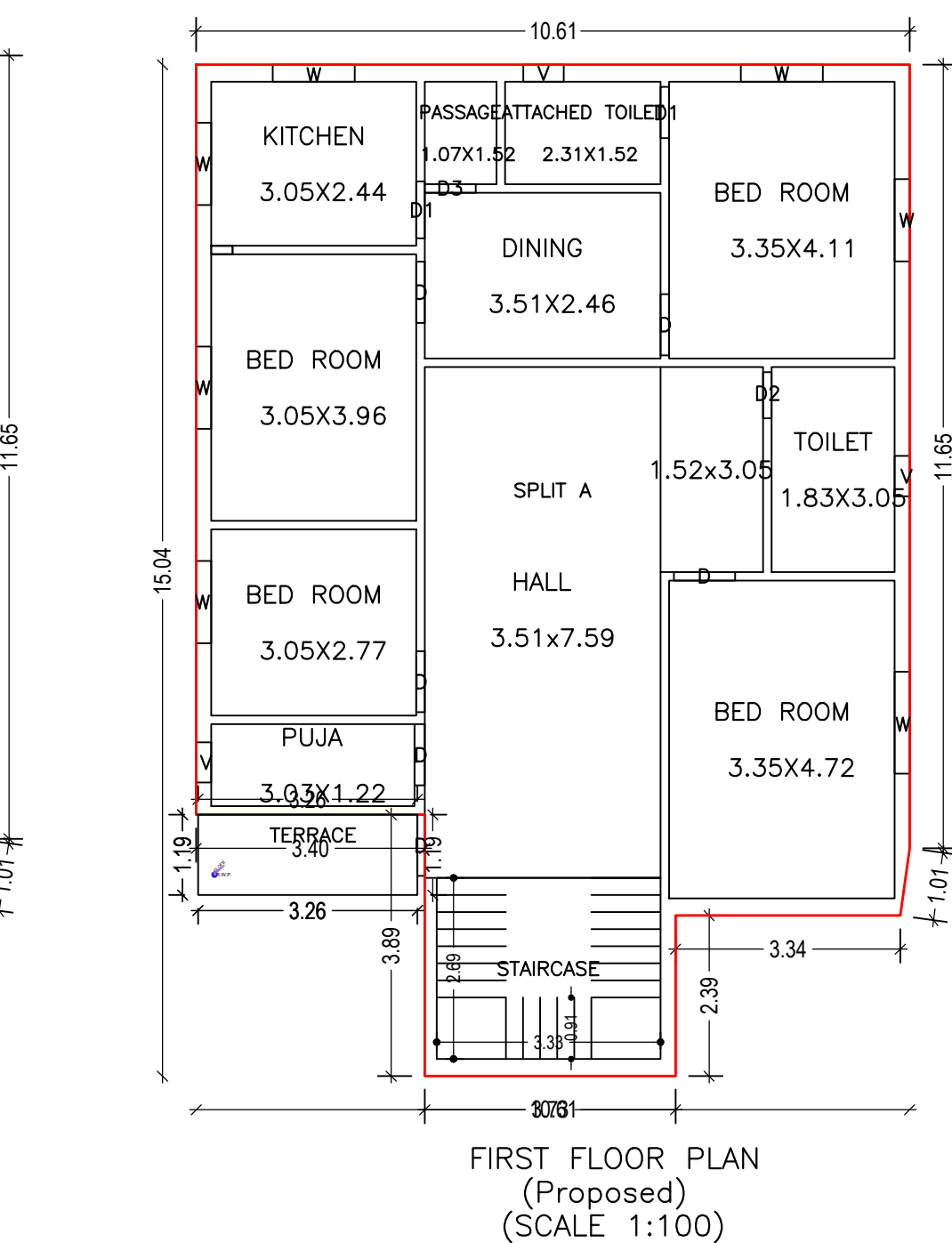
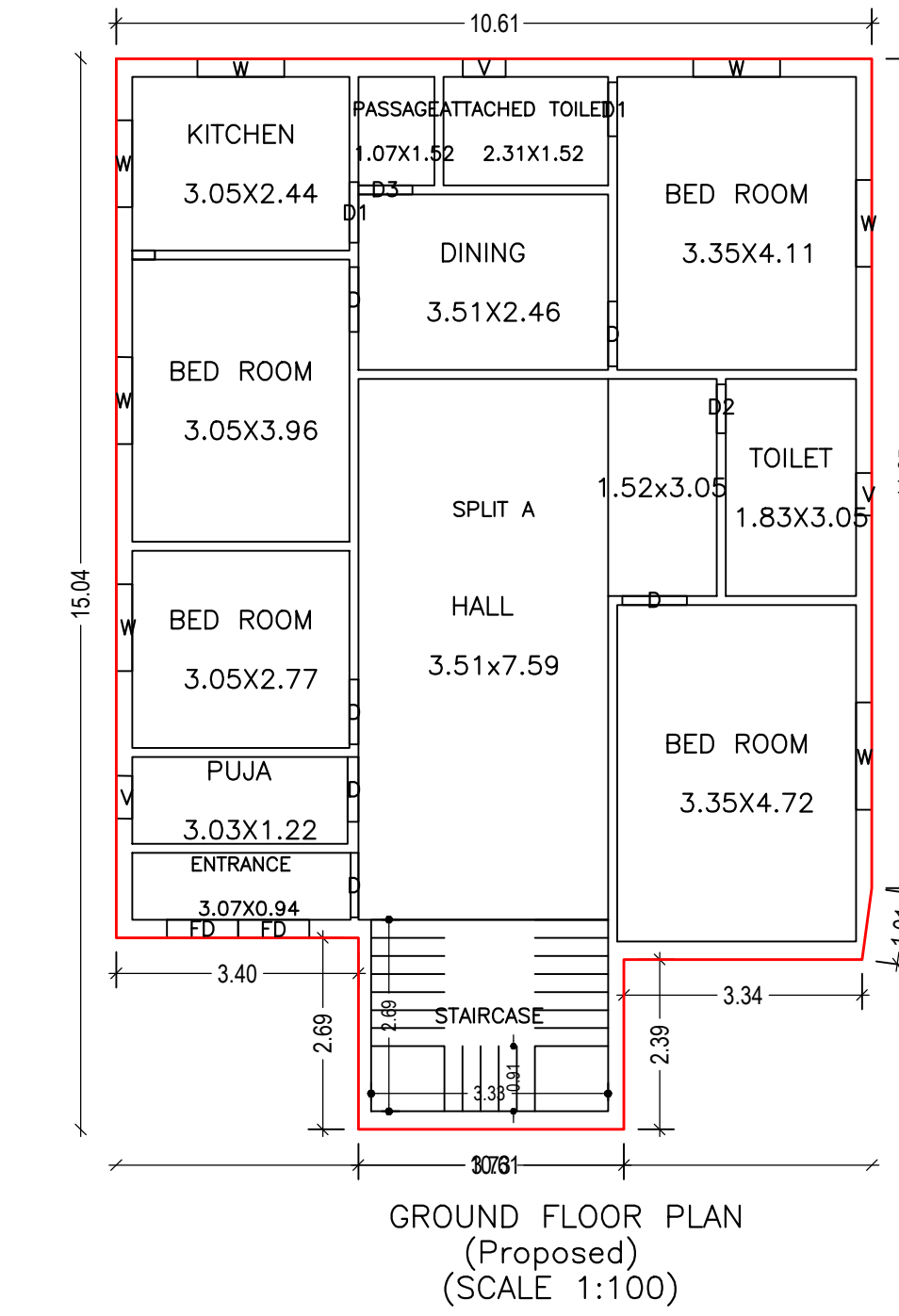

Building USE/SUBUSE Details

Building Name	Building Use	Building SubUse	Building Structure
ARCHANA KUMARI (A BUILDING)	Residential	Bungalow/ Dwelling / Non Apartment	Non-Highrise

FAR & Tenement Details (Table 4c-1)

Building	No. of Same Bldg	Total Built Up Area (Sq.mt.)	Proposed FAR Area (Sq.mt.)	Total FAR Area (Sq.mt.)	Total Consumed Additional FAR Area (Sq.mt.)	Trmt (No.)
ARCHANA KUMARI (A BUILDING)	1	418.14	418.14	418.14	418.14	01
Grand Total :	1	418.14	418.14	418.14	418.14	01

LTP NAME AND SIGNATURE	STRUCTURAL ENG'S NAME AND SIGNATURE	BUILDER NAME AND SIGNATURE	DIGITAL SIGNATURE
RAWNIT KUMAR GUNPC/ENG/0004/2019			