

Proposal Basic Information	
Proposal File No.	GUNPC/BP/0015/W12/2024
Owner Name	SUNIL KUMAR GUPTA
Khata No	168
Plot No	990
Village Name	Tower Chowk
Use	Mixed
SubUse	Resi+Comm

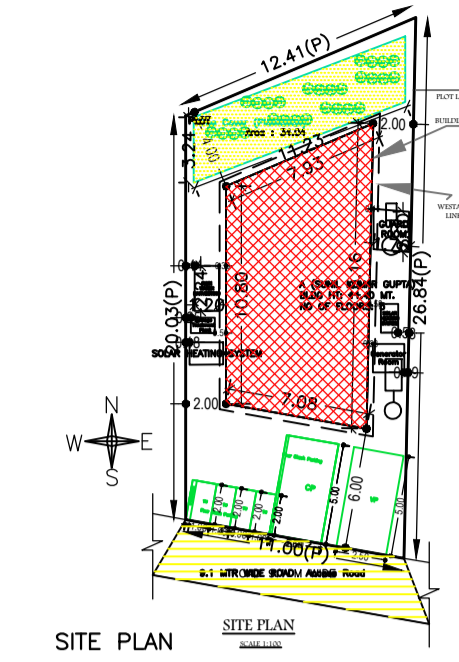
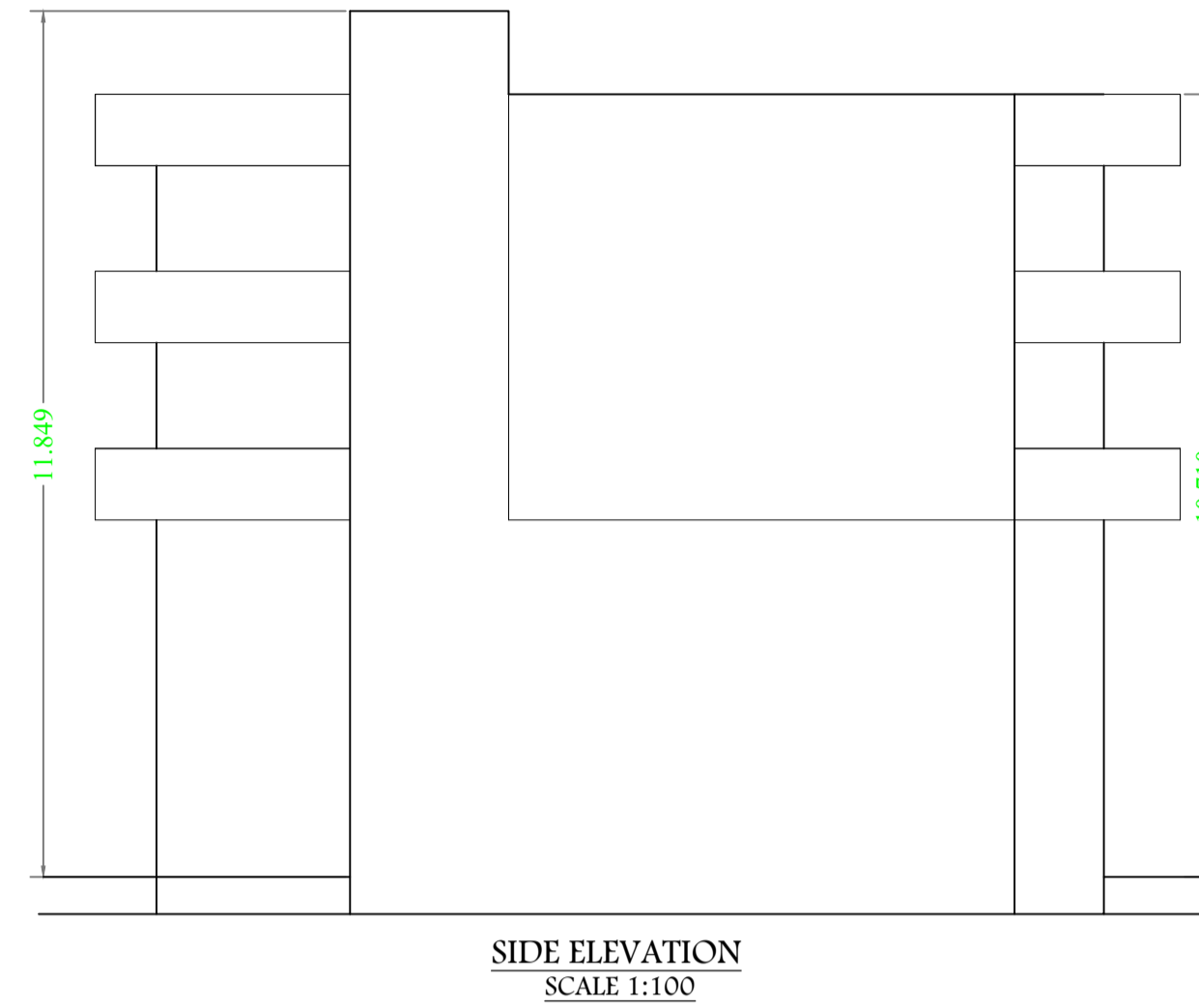
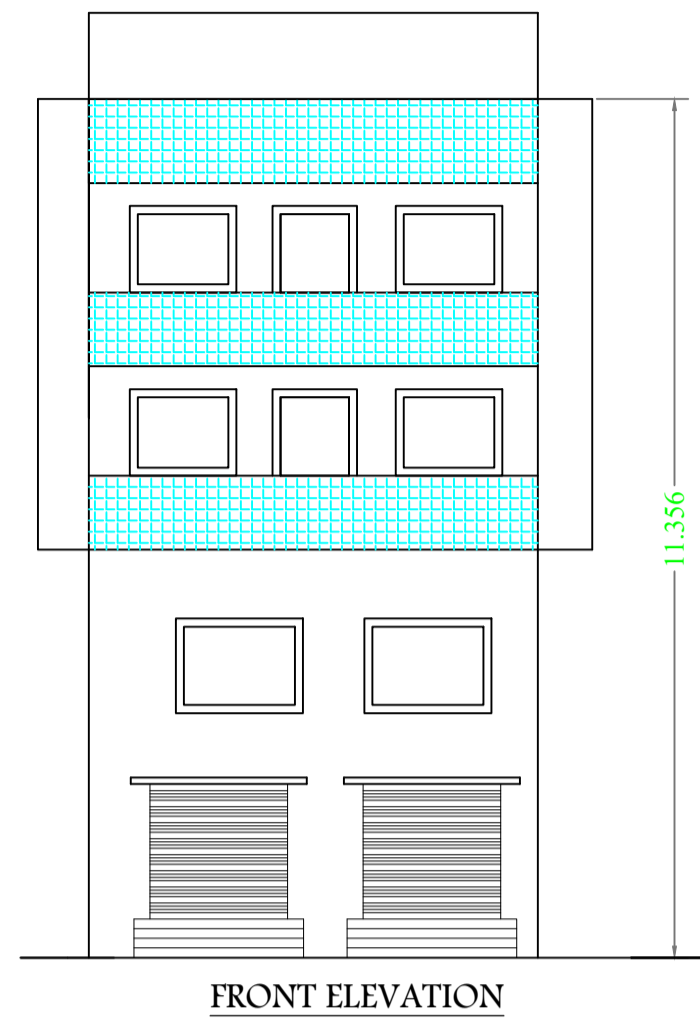
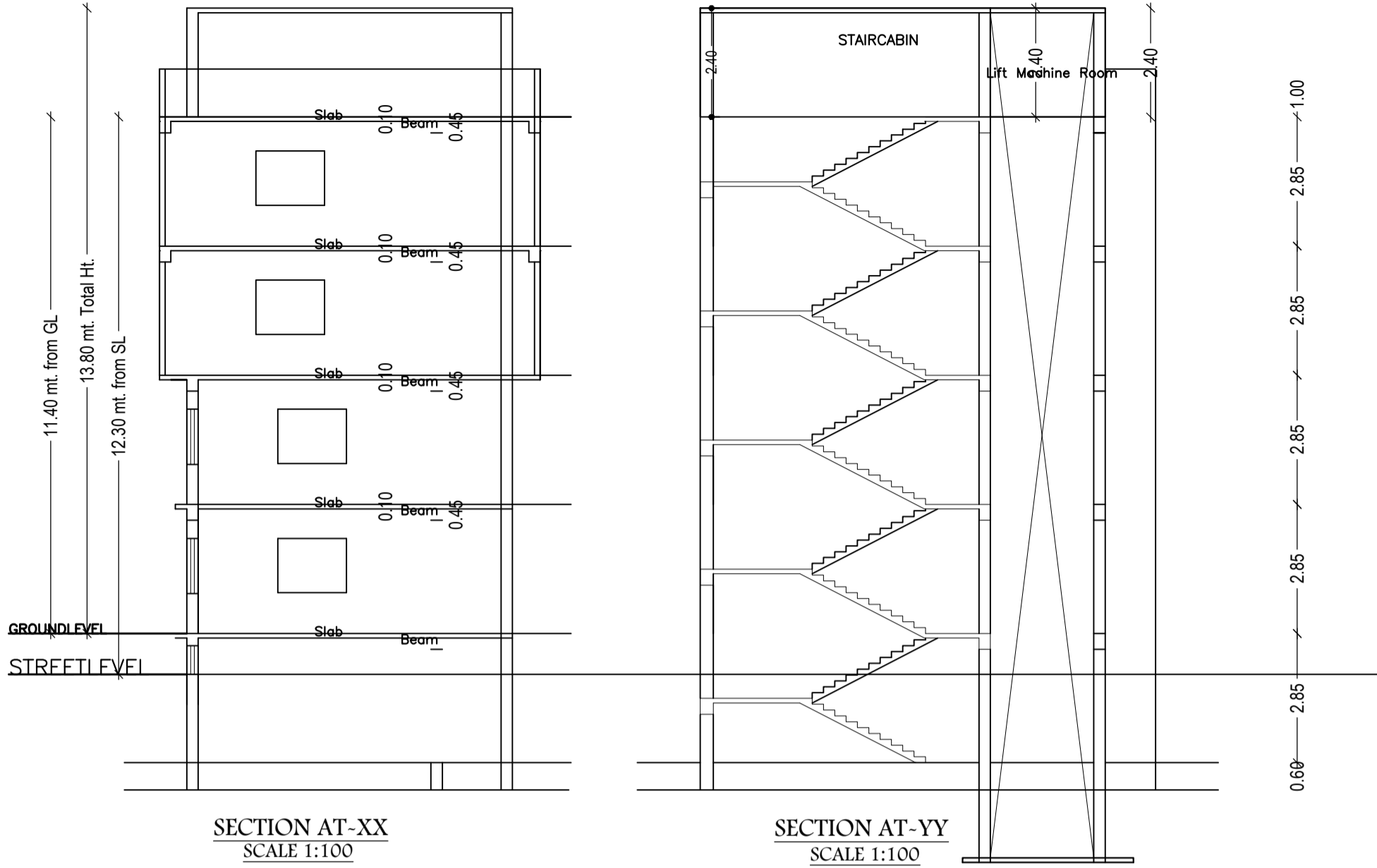

UnitBUA Table for Building :A (SUNIL KUMAR GUPTA)

FLOOR	Name	UnitBUA Type	UnitBUA Area	Carpet Area	No. of Rooms	No. of Tenement
TYPICAL - 2&3 FLOOR PLAN	SPLIT A	FLAT	61.19	59.16	1	2
FIRST FLOOR PLAN	SHOP 6.73X11.90	OTHER	61.19	59.16	1	1
UPPER GROUND FLOOR PLAN	SHOP 6.73X11.90	OTHER	61.19	59.16	1	1
LOWER GROUND FLOOR PLAN	department store	GODOWN	61.19	59.16	1	1
Total:	-	-	305.96	295.80	5	5

Building :A (SUNIL KUMAR GUPTA)

Floor Name	Total Built Up Area (Sq.mt.)	Deductions (Area in Sq.mt.)		Proposed FAR Area (Sq.mt.)		Total FAR Area (Sq.mt.)	Total Consumed Additional FAR Area (Sq.mt.)	Tnmt (No.)
		Lift	Balcony	Resi.	Commercial			
Lower Ground Floor	92.36	7.84	0.00	0.00	84.52	84.52	84.52	01
Upper Ground Floor	92.36	7.84	0.00	0.00	84.52	84.52	84.52	01
First Floor	92.36	0.00	0.00	0.00	92.36	92.36	92.36	01
Second Floor	118.36	7.84	6.75	103.77	0.00	103.77	103.77	01
Third Floor	118.36	7.84	6.75	103.77	0.00	103.77	103.77	01
Terrace Floor	0.00	0.00	0.00	0.00	0.00	0.00	0.00	00
Total:	513.80	31.36	13.50	207.54	261.40	468.94	468.94	05
Total Number of Same Buildings :	1							
Total :	513.80	31.36	13.50	207.54	261.40	468.94	468.94	05

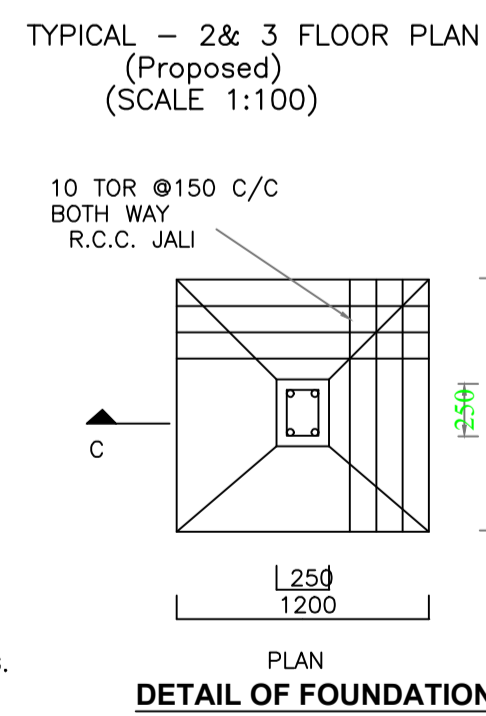
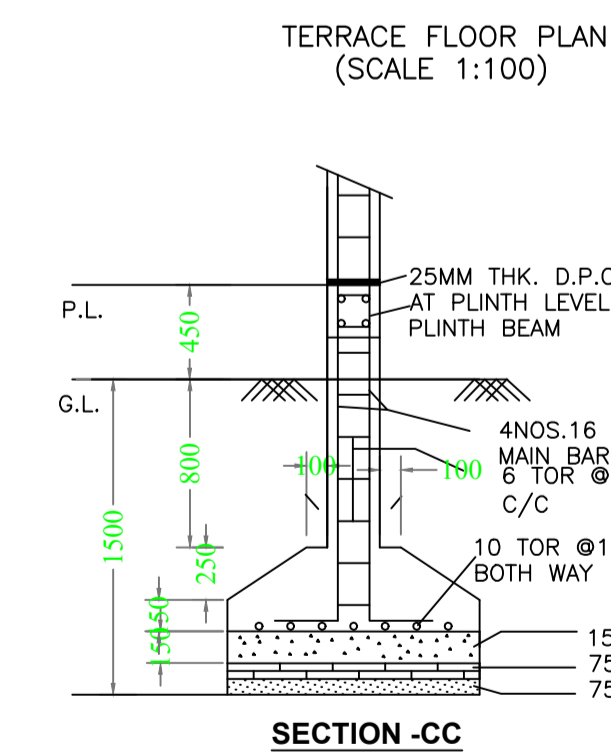
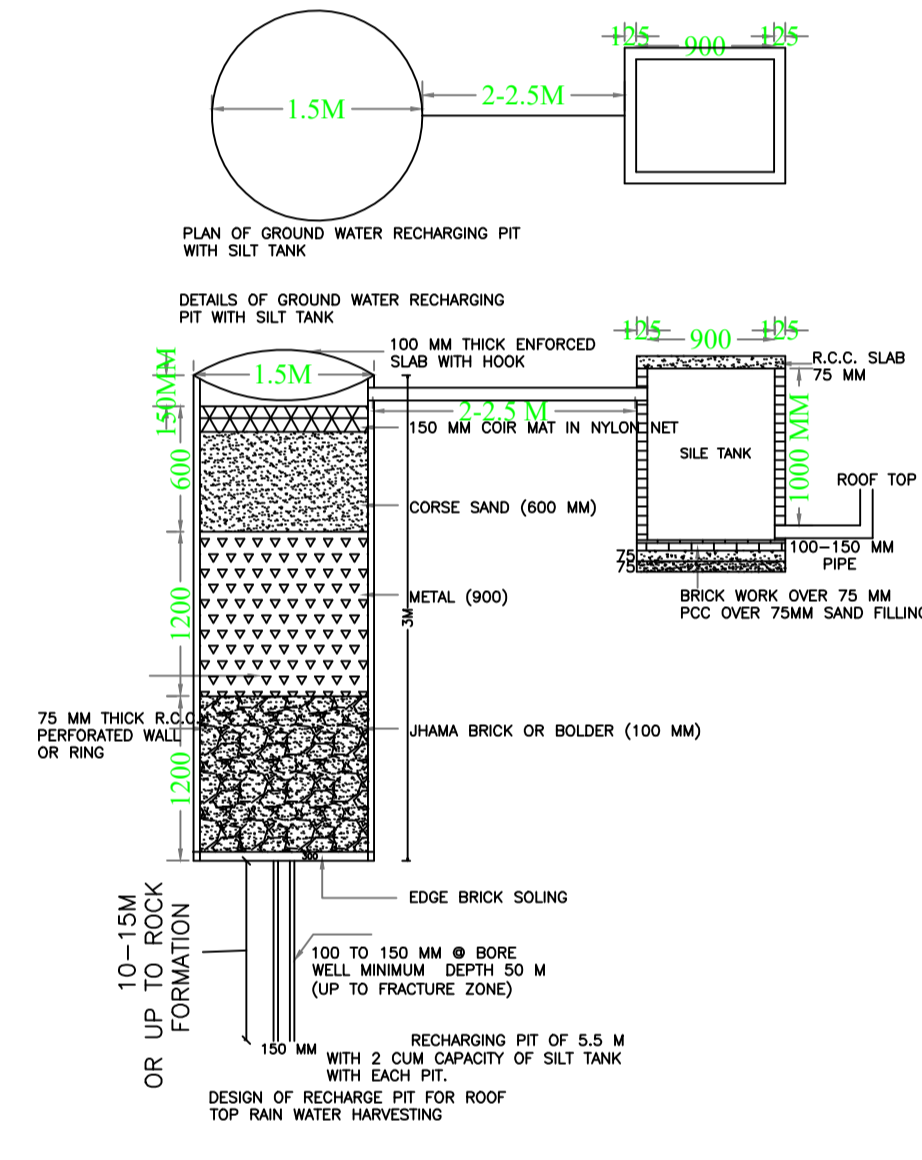
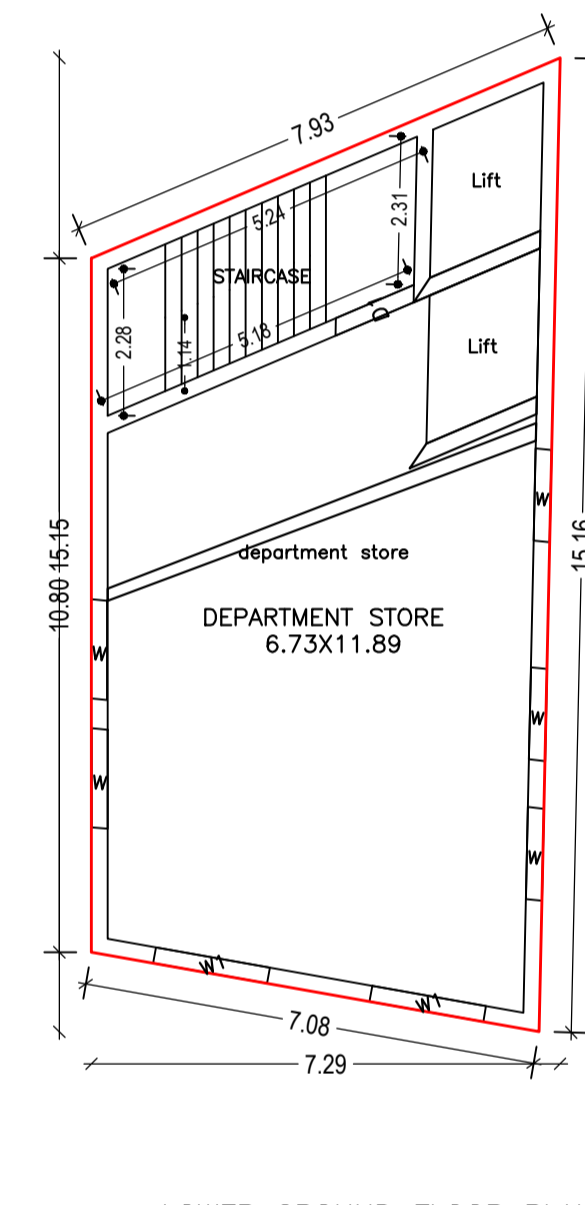
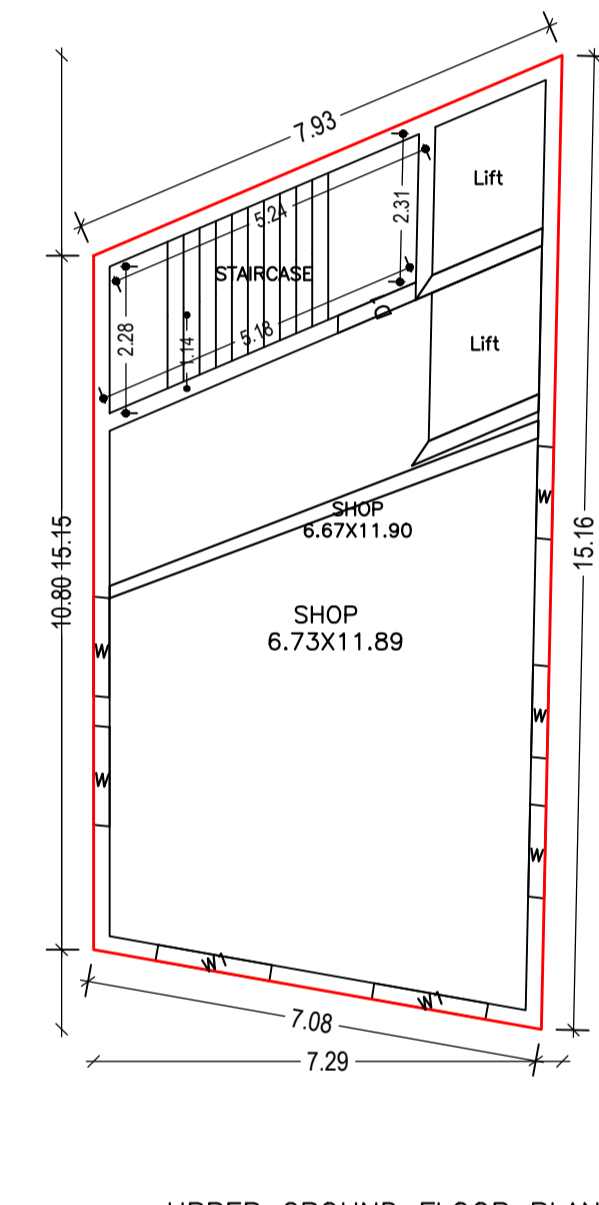
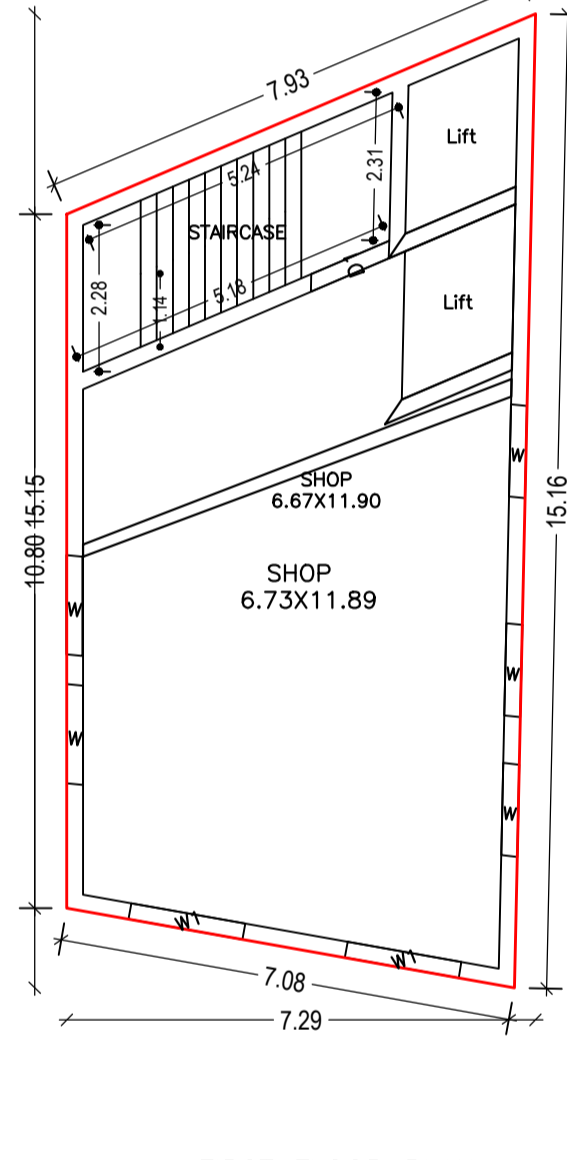
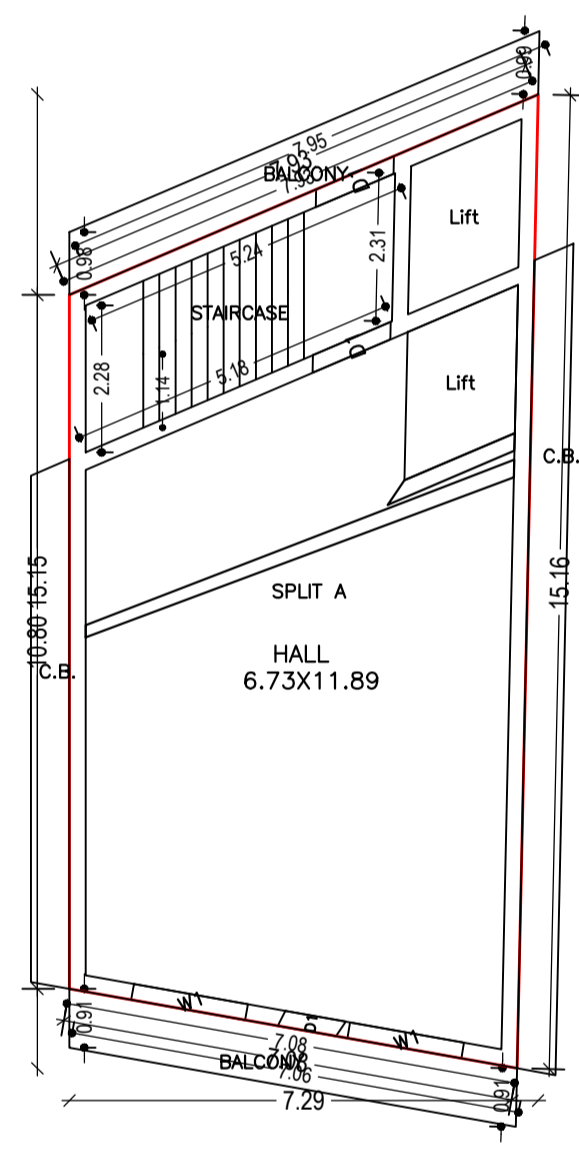
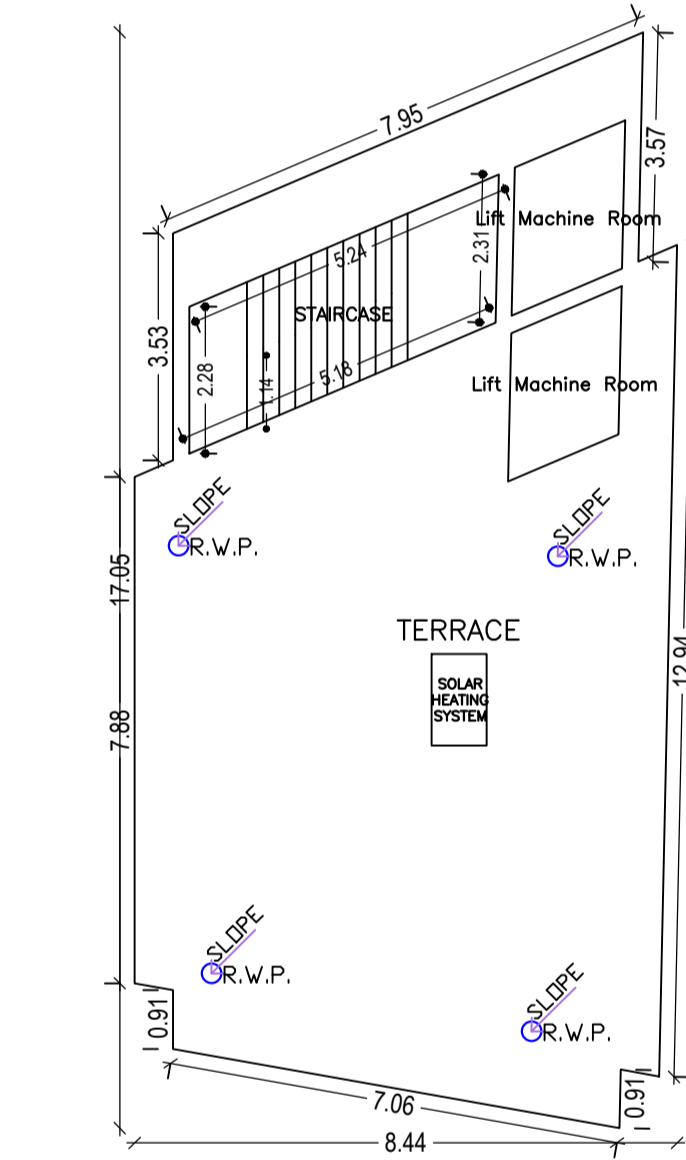

FAR & Tenement Details (Table 4c-1)

Building	No. of Same Bldg	Total Built Up Area (Sq.mt.)	Deductions (Area in Sq.mt.)	Proposed FAR Area (Sq.mt.)	Total FAR Area (Sq.mt.)	Total Consumed Additional FAR Area (Sq.mt.)	Tnmt (No.)
A (SUNIL KUMAR GUPTA)	1	513.80	31.36	13.50	207.54	261.40	468.94
Grand Total	1	513.80	31.36	13.50	207.54	261.40	468.94

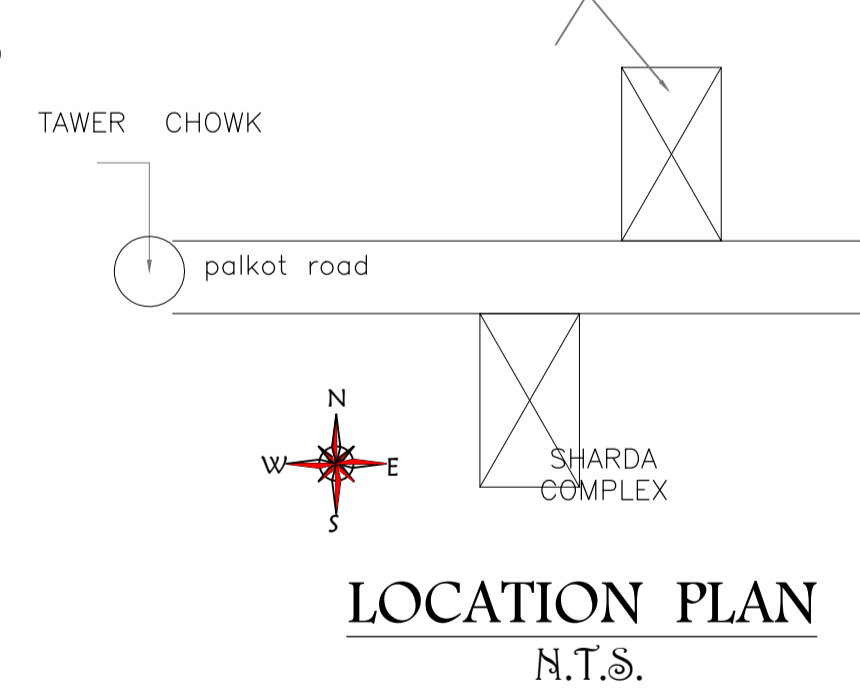
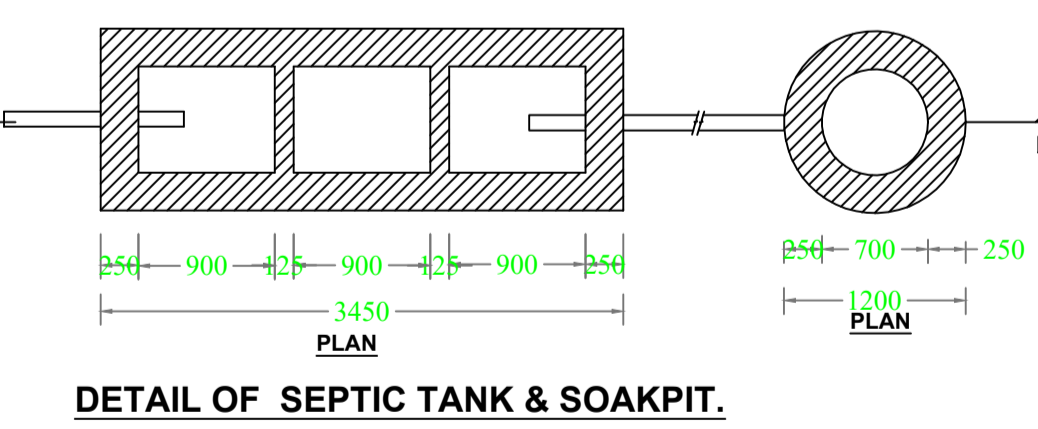

Building USE/SUBUSE Details

Building Name	Building Use	Building SubUse	Building Structure
A (SUNIL KUMAR GUPTA)	Commercial	Res+Comm Bldg	Non-Highrise

COLOR INDEX

Color	Description
Green	Permissible Coverage area (60.00%)
Red	Proposed Coverage Area (35.51%)
Blue	Total Prop. Coverage Area (35.51%)
Yellow	Balance coverage area (24.49%)

Balcony Calculations Table

FLOOR	SIZE	AREA	TOTAL AREA
TYPICAL - 2&3 FLOOR	3.90 X 7.96 X 1 X 2	14.30	27.92
FLAT	3.90 X 7.96 X 1 X 2	12.72	27.92
Total	-	-	27.92

SCHEDULE OF DOOR:

BUILDING NAME	NAME	LENGTH	HEIGHT	NOS
A (SUNIL KUMAR GUPTA)	D1	0.95	2.10	02
A (SUNIL KUMAR GUPTA)	D1	1.32	2.10	05

SCHEDULE OF WINDOW /VENTILATION:

BUILDING NAME	NAME	LENGTH	HEIGHT	NOS
A (SUNIL KUMAR GUPTA)	W	1.43	2.90	09
A (SUNIL KUMAR GUPTA)	W	1.54	2.50	06
A (SUNIL KUMAR GUPTA)	W1	1.80	1.20	10

Buildingwise Floor FAR Details

Floor Name	Building Name A (SUNIL KUMAR GUPTA)		Total	
	Proposed Built Up Area (Sq.mt.)	Proposed FAR Area (Sq.mt.)	Total Proposed Built Up Area (Sq.mt.)	Total FAR Area (Sq.mt.)
Lower Ground Floor	92.36	84.52	92.36	84.52
Upper Ground Floor	92.36	84.52	92.36	84.52
First Floor	92.36	92.36	92.36	92.36
Second Floor	118.36	103.77	118.36	103.77
Third Floor	118.36	103.77	118.36	103.77
Terrace Floor	0.00	0.00	0.00	0.00
Total:	513.80	468.94	513.80	468.94

Required Parking (Table 7a)

Building Name	Type	SubUse	Area (Sq.mt.)	Units		Car		Visitors Car		TwoWheeler	
				Reqd.	Prop.	Reqd./Unit	Reqd.	Prop.	Reqd./Unit	Reqd.	Prop.
A (SUNIL KUMAR GUPTA)	Residential	Residential Bldg/Apartment	> 0	1	2.00	1	2	-	-	-	-
A (SUNIL KUMAR GUPTA)	Commercial	Res+Comm Bldg	> 0	100	220.73	1	2	-	-	1	5
Total:	-	-	> 0	100	220.73	-	-	-	-	1	5
Total:	-	-	-	-	-	4	4	-	-	1	7

Parking Check (Table 7b)

Vehicle Type	No.	Area	No.	Area
Car	-	-	1	12.50
Four Stack Car	-	-	3	37.50
Total Car	4	50.00	4	50.00
Visitor's Car Parking	-	-	1	12.50
Total Visitor Parking	1	12.50	1	12.50
TwoWheeler	-	-	4	8.00
Four Stack	-	-	12	24.00
TwoWheeler	-	-	1	2.00
Total TwoWheeler	7	14.00	16	32.00
Total	-	76.50	-	126.50

LTP NAME AND SIGNATURE	STRUCTURAL ENG'S NAME AND SIGNATURE	BUILDER NAME AND SIGNATURE	DIGITAL SIGNATURE
DEEPAK DIWAN GUNPC/ARC/0003/2017			