

Proposal Basic Information

Proposal File No.	GUNPC/BP/0002/W01/2024
Owner Name	NIRMALA LAKRA
Khata No	4
Plot No	108
Village Name	Dundurya
Use	Residential
SubUse	Bungalow/ Dwelling / Non Apartment

Building USE/SUBUSE Details

Building Name	Building Use	Building SubUse	Building Structure
A (NIRMALA LAKRA)	Residential	Bungalow/ Dwelling / Non Apartment	Non-Highrise

COLOR INDEX

PLOT BOUNDARY	Black
ABUTTING ROAD	Red
PROPOSED CONSTRUCTION	Green
COMMON PLOT	Yellow
ROAD WIDENING AREA	Blue
EXISTING (To be retained)	Orange
EXISTING (To be demolished)	Light Blue

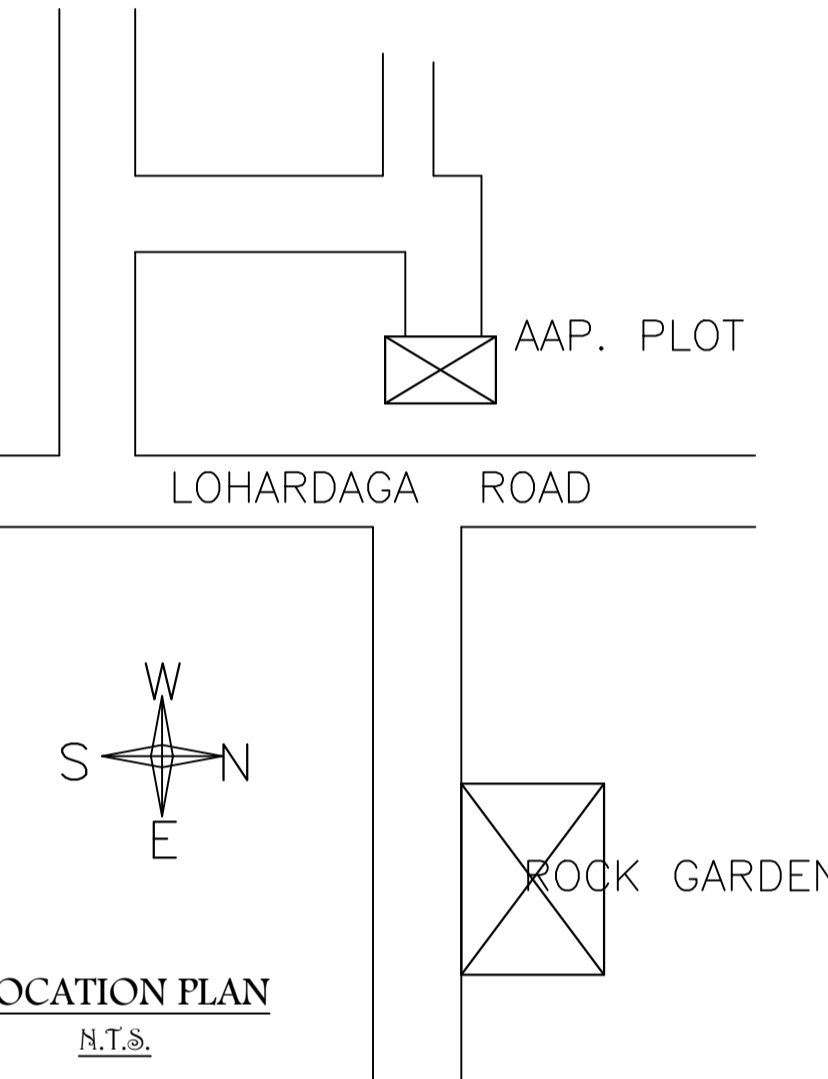
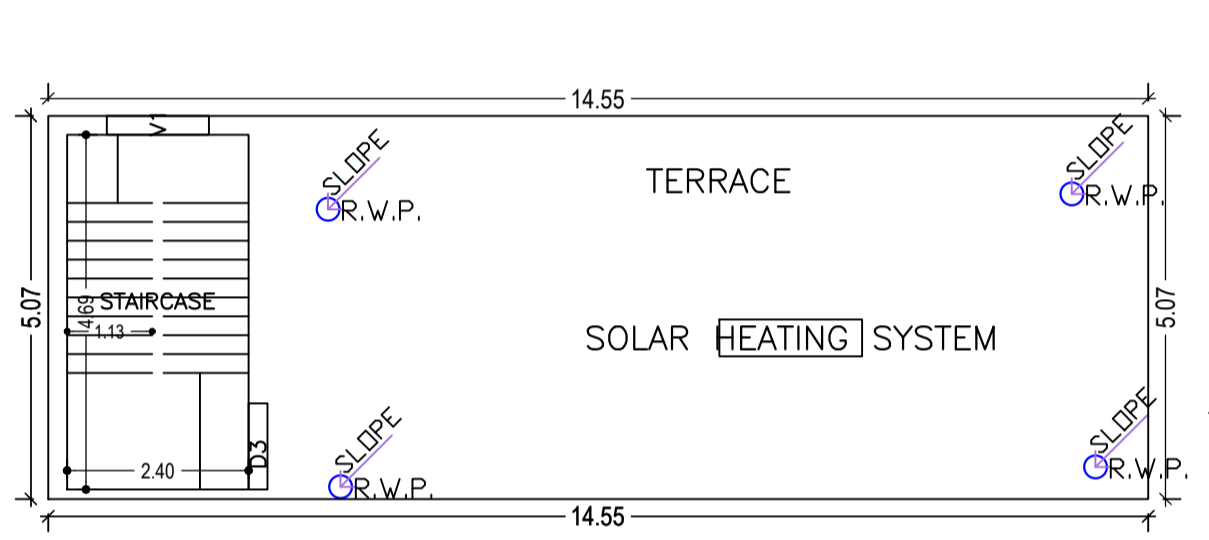
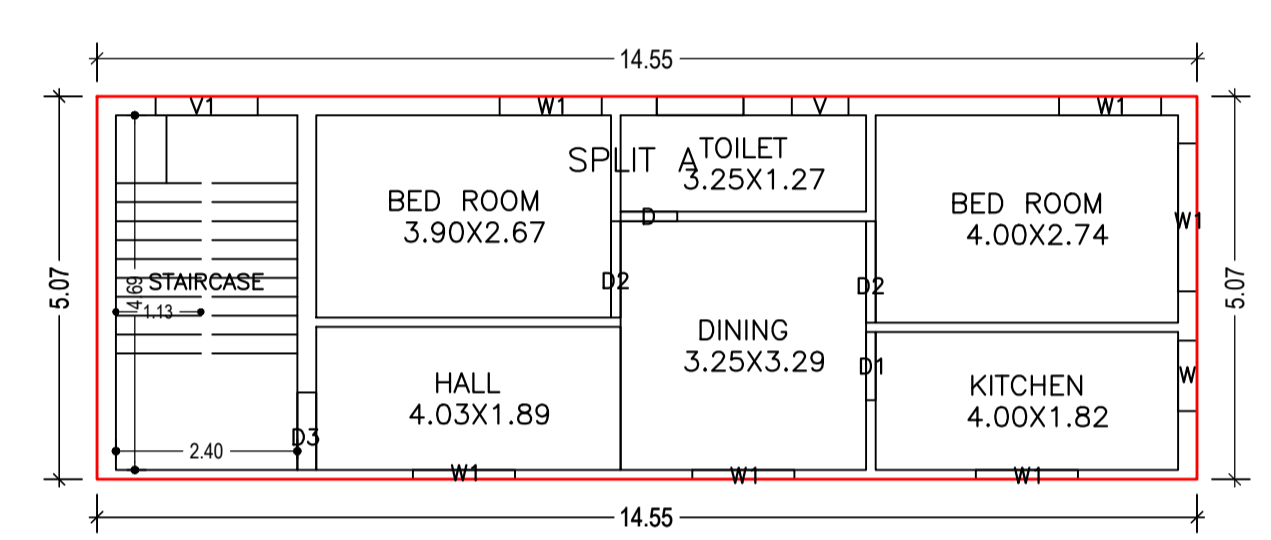
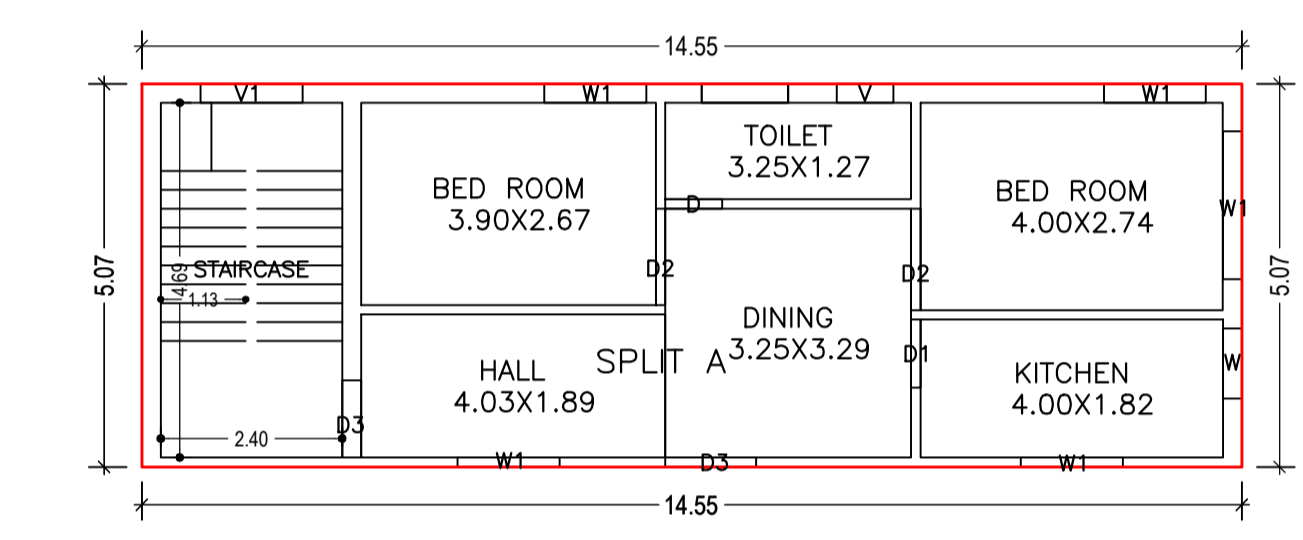

UnitBUA Table for Building :A (NIRMALA LAKRA)

FLOOR	Name	UnitBUA Type	UnitBUA Area	Carpet Area	No. of Rooms	No. of Tenement
GROUND FLOOR PLAN	SPLIT A	FLAT	221.14	220.28	6	1
TYPICAL - 1& 2 FLOOR PLAN	SPLIT A	FLAT	0.00	0.00	6	0
Total:	-	-	221.14	220.28	18	1

Building :A (NIRMALA LAKRA)

Floor Name	Total Built Up Area (Sq.mt.)	Proposed FAR Area (Sq.mt.) Resi.	Total FAR Area (Sq.mt.)	Total Consumed Additional FAR Area (Sq.mt.)	Trmt (No.)
Ground Floor	73.71	73.71	73.71	73.71	01
First Floor	73.71	73.71	73.71	73.71	00
Second Floor	73.71	73.71	73.71	73.71	00
Terrace Floor	0.00	0.00	0.00	0.00	00
Total :	221.13	221.13	221.13	221.13	01
Total Number of Same Buildings :	1				
Total :	221.13	221.13	221.13	221.13	01

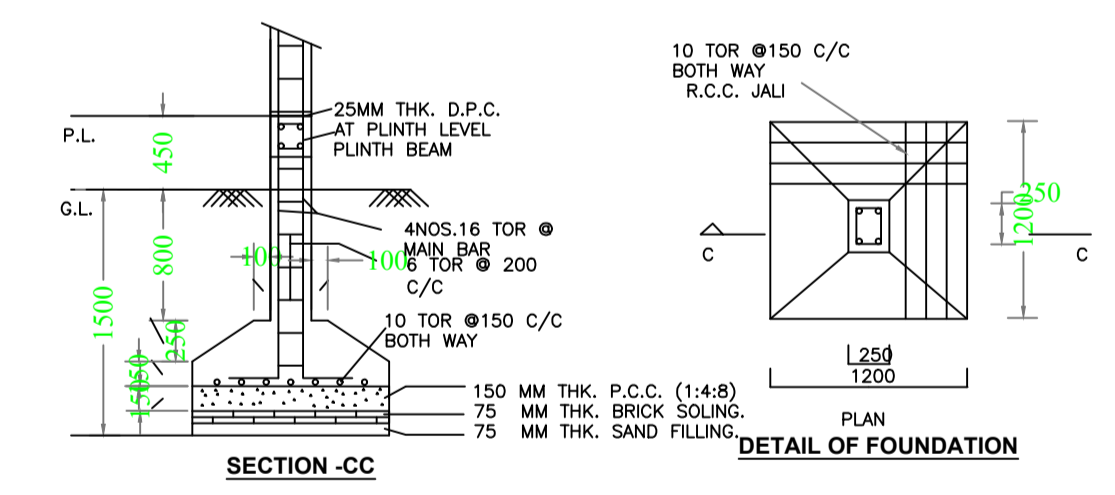
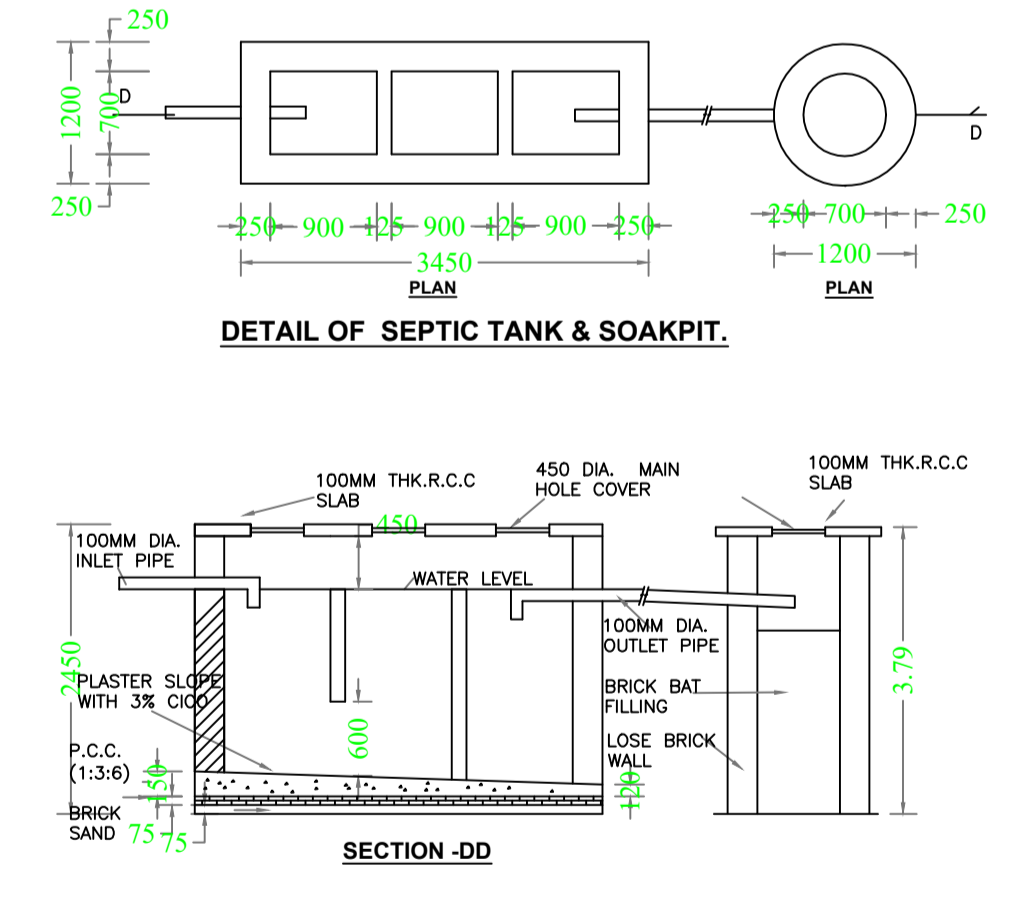
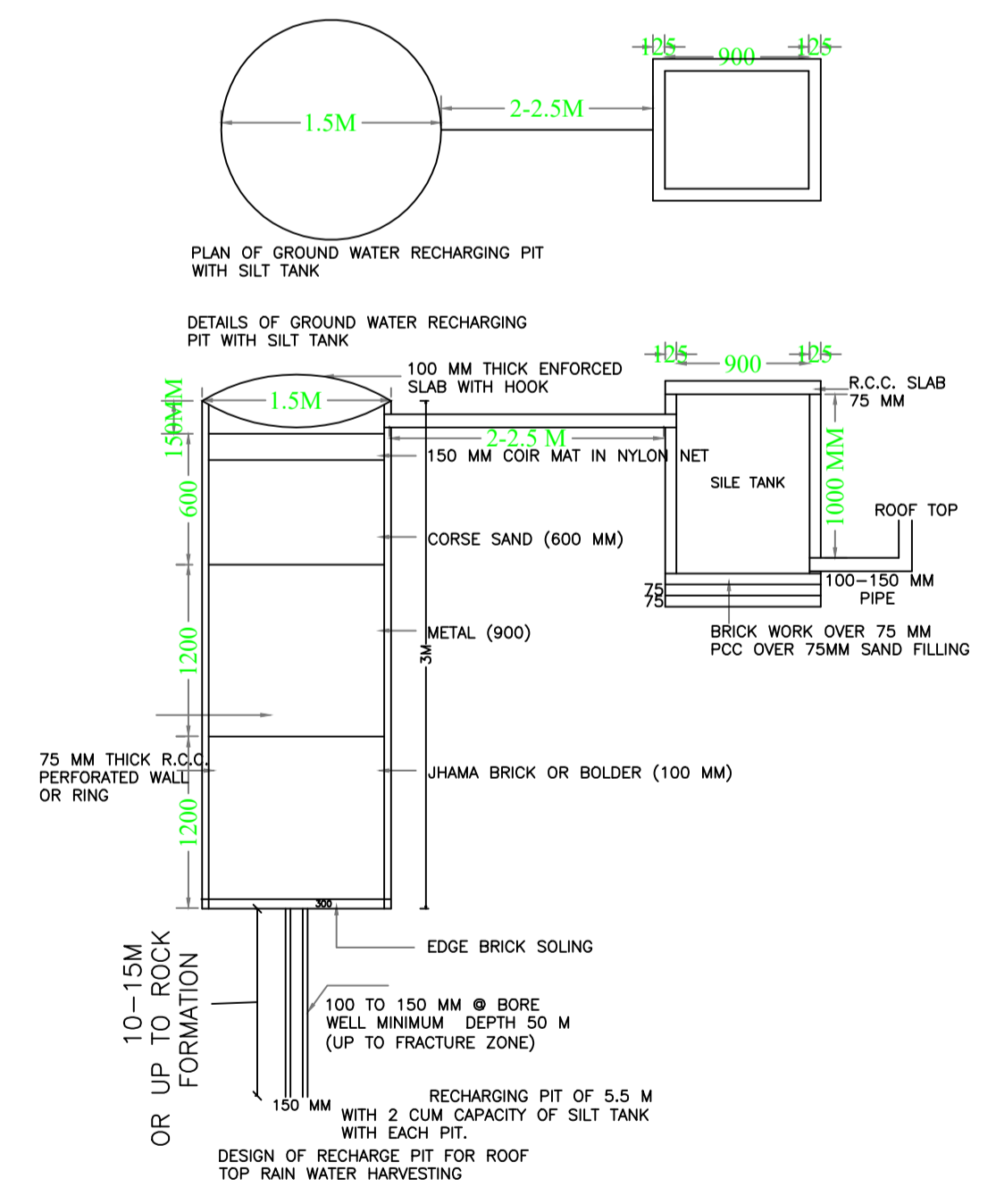
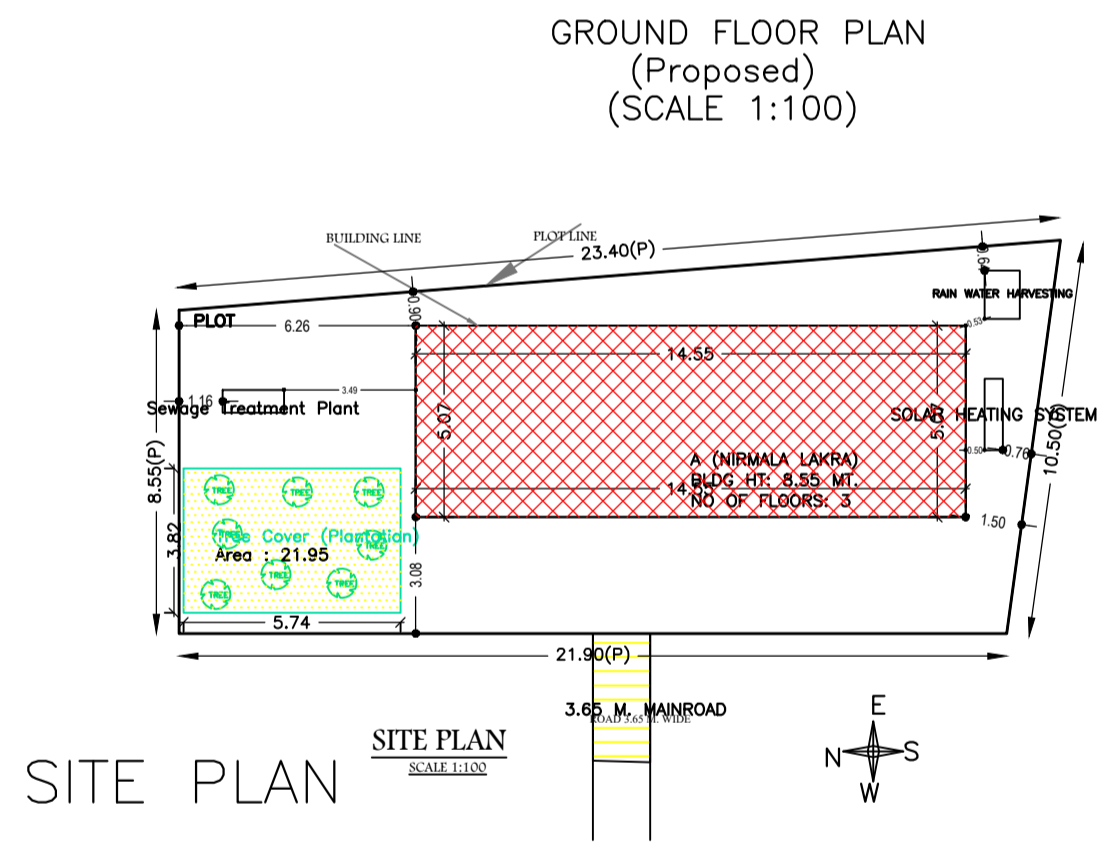

SCHEDULE OF DOOR:

BUILDING NAME	NAME	LENGTH	HEIGHT	NOS
A (NIRMALA LAKRA)	D	0.75	2.10	03
A (NIRMALA LAKRA)	D1	0.90	2.10	03
A (NIRMALA LAKRA)	D3	1.02	2.10	03
A (NIRMALA LAKRA)	D3	1.20	2.10	01
A (NIRMALA LAKRA)	D2	1.28	2.10	03
A (NIRMALA LAKRA)	D2	1.34	2.10	03

SCHEDULE OF WINDOW/VENTILATION:

BUILDING NAME	NAME	LENGTH	HEIGHT	NOS
A (NIRMALA LAKRA)	V	0.75	0.60	03
A (NIRMALA LAKRA)	W	0.93	1.20	03
A (NIRMALA LAKRA)	W1	1.35	1.20	14
A (NIRMALA LAKRA)	V1	1.35	1.20	04
A (NIRMALA LAKRA)	W1	1.96	1.20	03

FAR & Tenement Details (Table 4c-1)

Building	No. of Same Bldg	Total Built Up Area (Sq.mt.)	Proposed FAR Area (Sq.mt.) Resi.	Total FAR Area (Sq.mt.)	Total Consumed Additional FAR Area (Sq.mt.)	Trmt (No.)
A (NIRMALA LAKRA)	1	221.13	221.13	221.13	221.13	01
Grand Total :	1	221.13	221.13	221.13	221.13	01

Buildingwise Floor FAR Details

Floor Name	Building Name A (NIRMALA LAKRA)		Total	
	Proposed Built Up Area (Sq.mt.)	Proposed FAR Area (Sq.mt.)	Total Proposed Built Up Area (Sq.mt.)	Total FAR Area (Sq.mt.)
Ground Floor	73.71	73.71	73.71	73.71
First Floor	73.71	73.71	73.71	73.71
Second Floor	73.71	73.71	73.71	73.71
Terrace Floor	0.00	0.00	0.00	0.00
Total :	221.13	221.13	221.13	221.13

AREA STATEMENT GUMLA NAGAR PARISHAD

PROJECT NO.: 1.0.68
VERSION DATE: 16/10/2020

PROJECT DETAIL:
Region: JHARKHAND URBAN LOCAL BODIES
District: GUMLA
Authority: GUMLA NAGAR PARISHAD
Inward No: GUNPC/BP/0002/W01/2024
Application Type: General Proposal
Project Type: Building Permission
Nature of Development: New
Location of Development Area: Old Area

Plot Use: Residential
Plot SubUse: Bungalow/ Dwelling / Non Apartment
PlotNearbyReligiousStructure: NA
Plot/SubPlot No: 108
North: -
South: -
East: -
West: -

AREA DETAILS:
AREA OF PLOT (Minimum) (A) 213.63
NET AREA OF PLOT (Gross Plot Area - Deduction from Gross Plot Area) 213.63
Deduction for Balance Plot Area (from Gross Plot Area)
Common Plot 21.95
Total 219.5
BALANCE AREA OF PLOT (Net Plot Area - Recreational/Amenity space) (A-Deductions) 191.68
PLOT AREA FOR COVERAGE (Net Plot Area) (A-Deductions) 213.63
Plot Area for FAR (Net Plot Area + Road Widening Area) (A-Deductions) 213.63

COVERAGE CHECK
Permissible Coverage area (70.00 %) 149.54
Proposed Coverage Area (34.50 %) 73.71
Total Prop. Coverage Area (34.5 %) 73.71
Balance coverage area (35.50 %) 75.83

FAR CHECK
Perm. FAR Area (1.500) 320.45
Total Perm. FAR area 320.45
Residential FAR 221.14
Proposed FAR Area 221.14
Total Proposed FAR Area 221.14
Consumed FAR (Factor) 1.04
Balance FAR Area 99.31

BUILT UP AREA CHECK
Total Proposed BuiltUp Area 221.13

ARCHITECT (Regd) DEEPAK DIWAN
ENGINEER (Regd)
SUPERVISOR (Regd)
OWNER (Regd) NIRMALA LAKRA

DEVELOPMENT AUTHORITY LOCAL BODY

LTP NAME AND SIGNATURE DEEPAK DIWAN GUNPC/ARC/0003/2017

STRUCTURAL ENG'S NAME AND SIGNATURE

BUILDER NAME AND SIGNATURE

DIGITAL SIGNATURE