

GROUND FLOOR PLAN (Proposed) (SCALE 1:100)

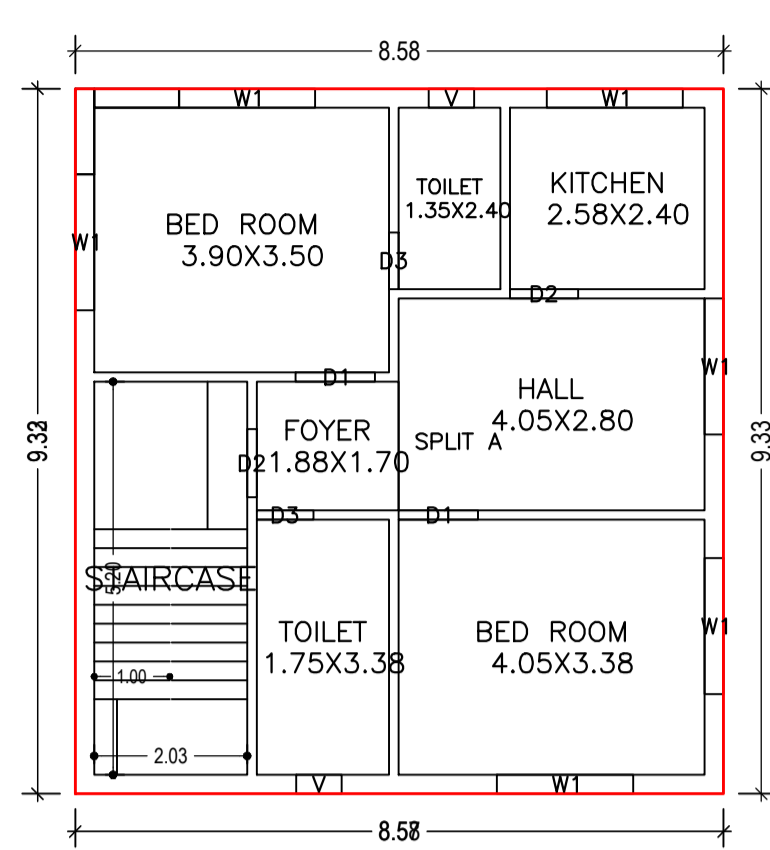

FIRST FLOOR PLAN (Proposed) (SCALE 1:100)

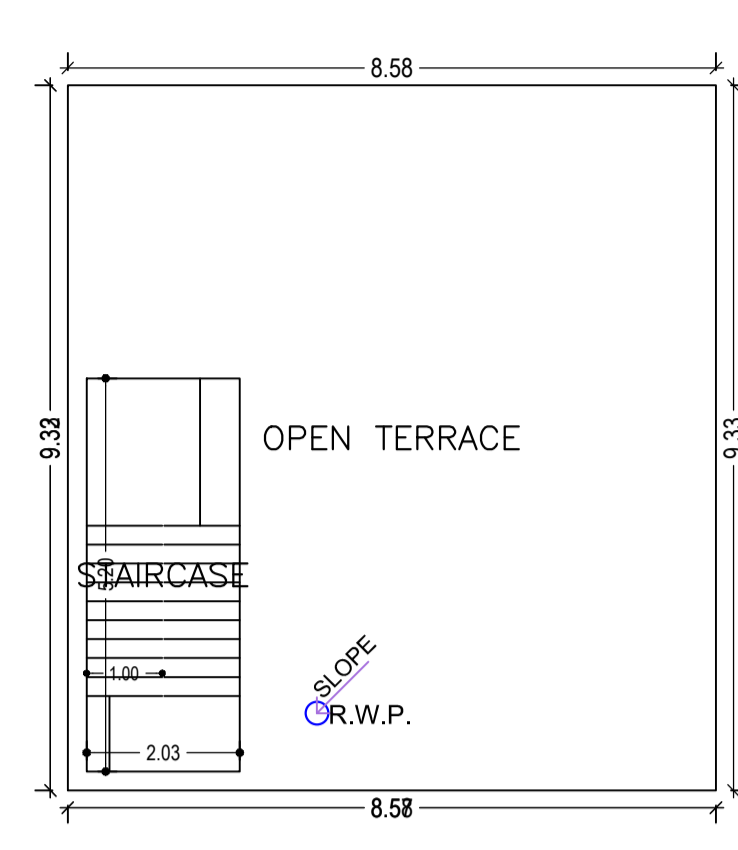

TERRACE FLOOR PLAN (SCALE 1:100)

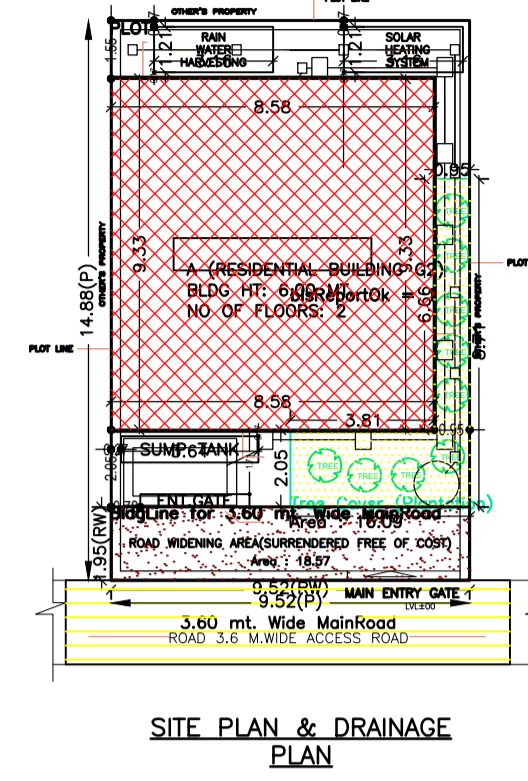

SITE PLAN

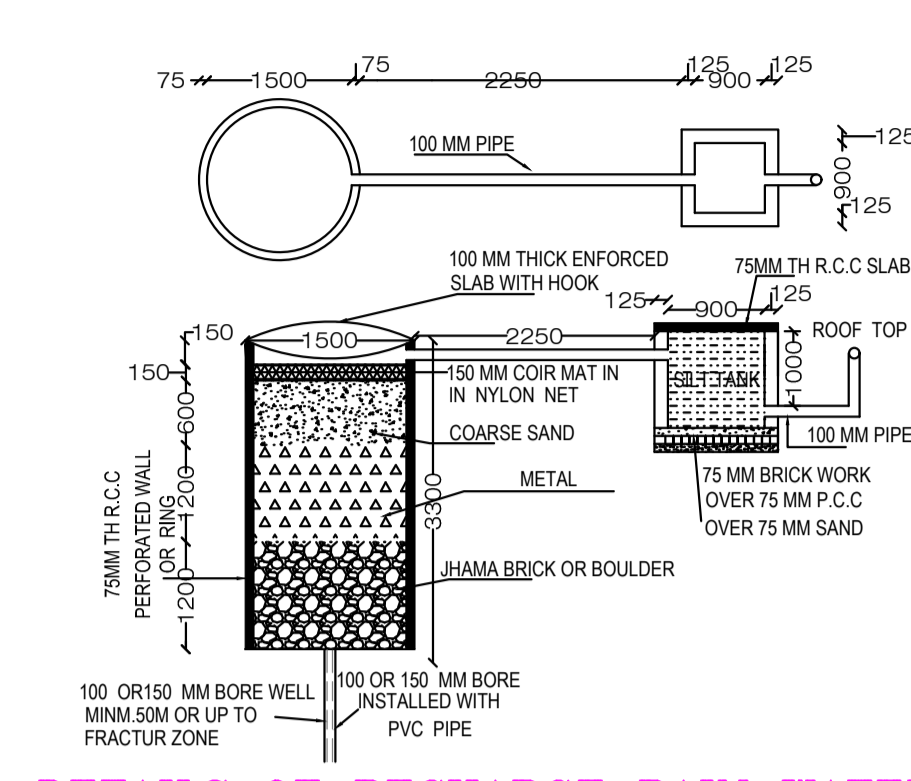

DETAILS OF RECHARGE RAIN WATER HARVESTING

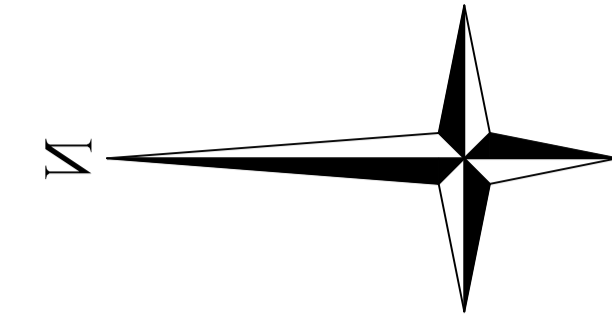

Proposal Basic Information	
Proposal File No.	GUNPC/BP/0003/W14/2024
Owner Name	MR. RAMESHWAR ORAON
Khata No.	08
Plot No.	412
Village Name	Karam Toli
Use	Residential
SubUse	Bungalow/ Dwelling / Non Apartment

Building USE/SUBUSE Details

Building Name	Building Use	Building SubUse	Building Structure
A (RESIDENTIAL BUILDING G2)	Residential	Bungalow/ Dwelling / Non Apartment	Non-Highrise

FAR & Tenement Details (Table 4c-1)

Building	No. of Same Bldg	Total Built Up Area (Sq.mt.)	Proposed FAR Area (Sq.mt.) Resi.	Total FAR Area (Sq.mt.)	Total Consumed Additional FAR Area (Sq.mt.)	Tnmt (No.)
A (RESIDENTIAL BUILDING G2)	1	159.92	159.92	159.92	159.92	01
Grand Total :	1	159.92	159.92	159.92	159.92	01

Buildingwise Floor FAR Details

Floor Name	Building Name A (RESIDENTIAL BUILDING G2)		Total	
	Proposed Built Up Area (Sq.mt.)	Proposed FAR Area (Sq.mt.)	Total Proposed Built Up Area (Sq.mt.)	Total FAR Area (Sq.mt.)
Ground Floor	79.96	79.96	79.96	79.96
First Floor	79.96	79.96	79.96	79.96
Terrace Floor	0.00	0.00	0.00	0.00
Total :	159.92	159.92	159.92	159.92

COLOR INDEX

PLOT BOUNDARY	Black
ABUTTING ROAD	Green
PROPOSED CONSTRUCTION	Red
COMMON PLOT	Yellow
ROAD WIDENING AREA	Blue
EXISTING (To be retained)	Orange
EXISTING (To be demolished)	Light Blue

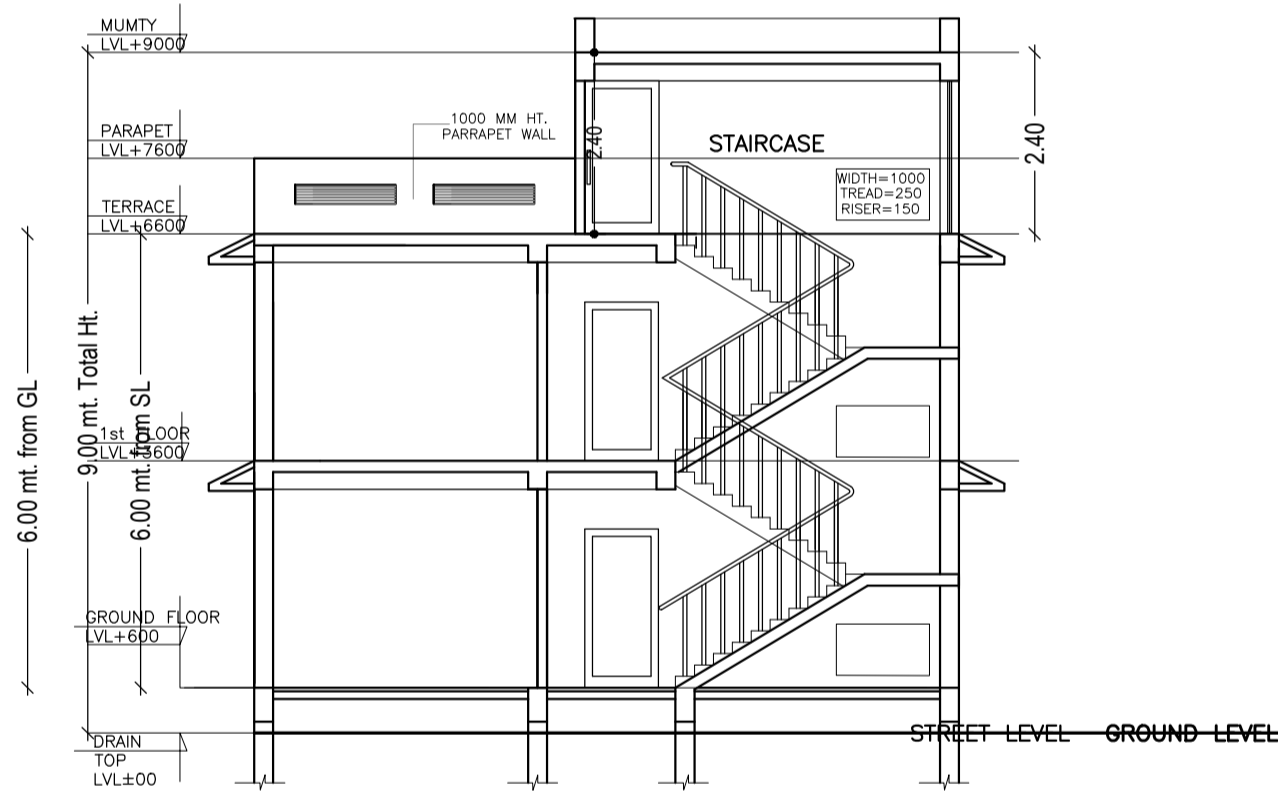

SECTION-A-A

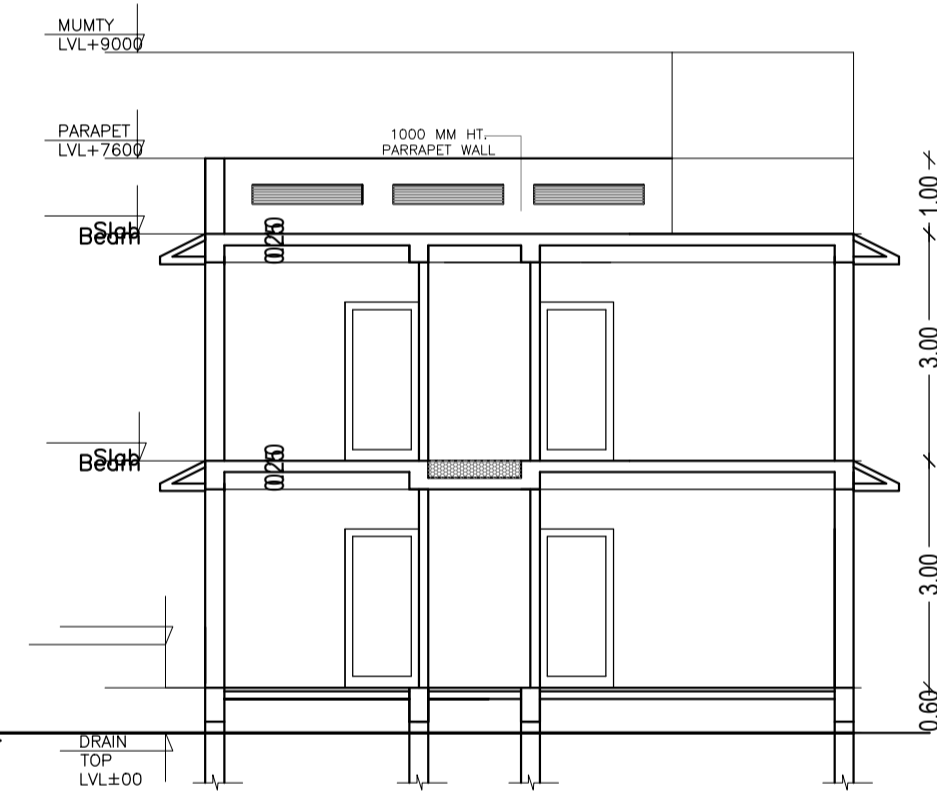

SECTION-B-B

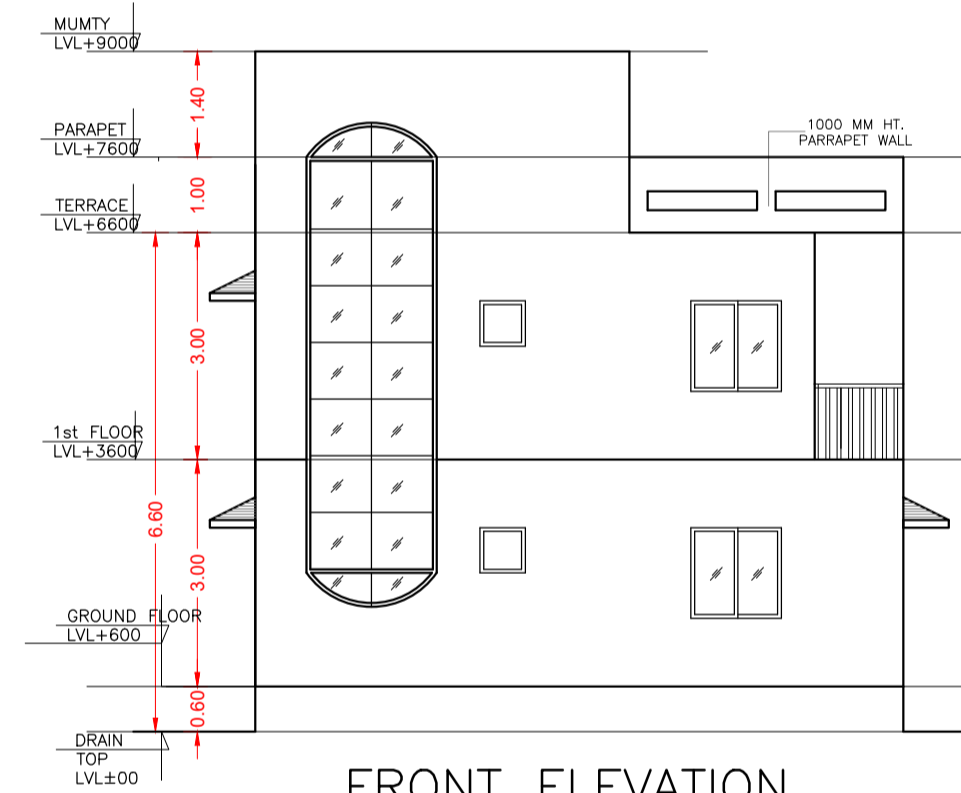

FRONT ELEVATION

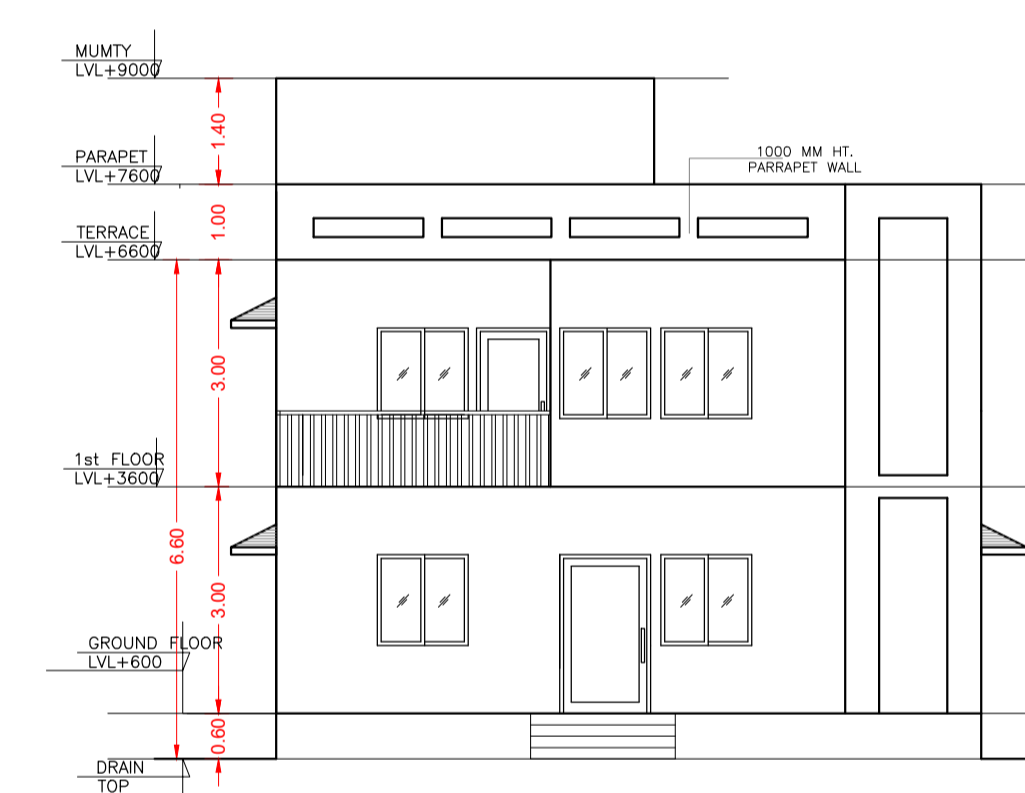

RIGHT ELEVATION

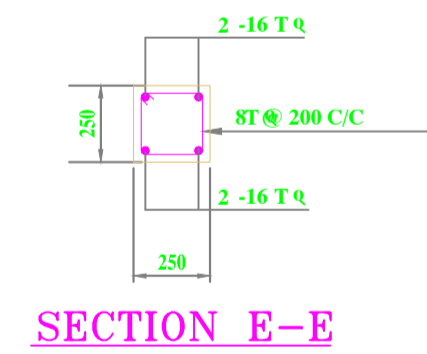

SECTION E-E

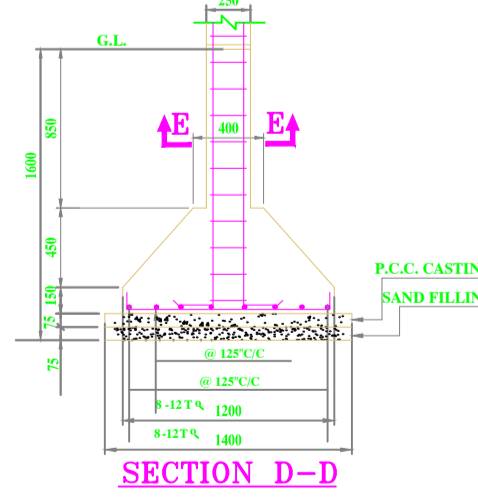

SECTION D-D

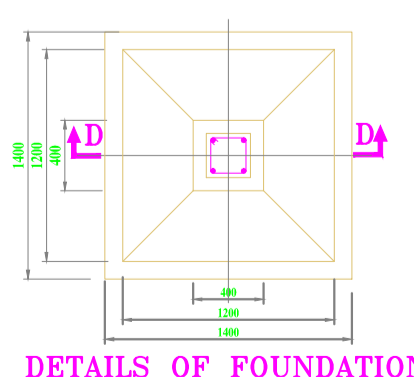

DETAILS OF FOUNDATION

SCHEDULE OF DOOR:

BUILDING NAME	NAME	LENGTH	HEIGHT	NOS
A (RESIDENTIAL BUILDING G2)	D3	0.75	2.10	04
A (RESIDENTIAL BUILDING G2)	D2	0.90	2.10	04
A (RESIDENTIAL BUILDING G2)	D1	1.05	2.10	05

SCHEDULE OF WINDOW/VENTILATION:

BUILDING NAME	NAME	LENGTH	HEIGHT	NOS
A (RESIDENTIAL BUILDING G2)	V	0.60	1.20	04
A (RESIDENTIAL BUILDING G2)	W1	1.80	1.20	12

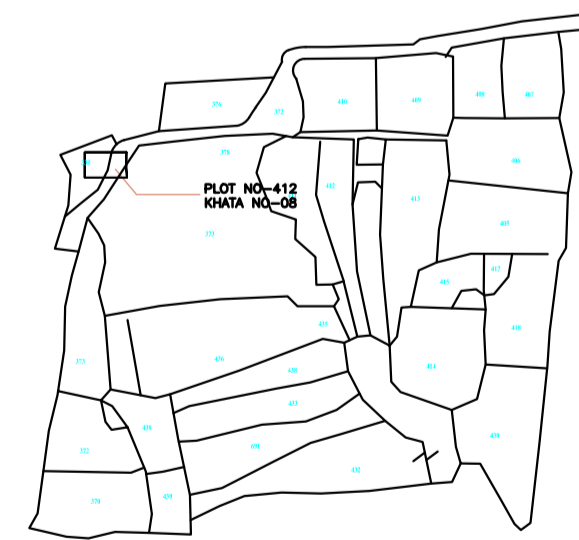

PLAN OF SEPTIC TANK (SCALE 1:50)

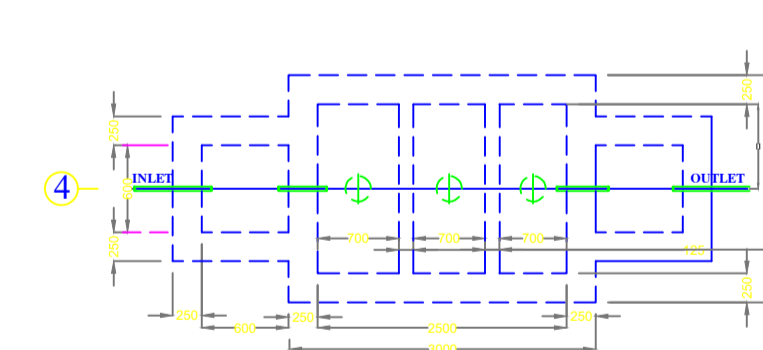

SECTION 4-4 (SCALE 1:50)

Building :A (RESIDENTIAL BUILDING G2)

Floor Name	Total Built Up Area (Sq.mt.)	Proposed FAR Area (Sq.mt.) Resi.	Total FAR Area (Sq.mt.)	Total Consumed Additional FAR Area (Sq.mt.)	Tnmt (No.)
Ground Floor	79.96	79.96	79.96	79.96	01
First Floor	79.96	79.96	79.96	79.96	00
Terrace Floor	0.00	0.00	0.00	0.00	00
Total :	159.92	159.92	159.92	159.92	01

UnitBUA Table for Building :A (RESIDENTIAL BUILDING G2)

FLOOR	Name	UnitBUA Type	UnitBUA Area	Carpet Area	No. of Rooms	No. of Tenement
GROUND FLOOR PLAN	SPLIT A	FLAT	159.92	158.80	7	1
FIRST FLOOR PLAN	SPLIT A	FLAT	0.00	0.00	7	0
Total:	-	-	159.92	158.80	14	1

LTP NAME AND SIGNATURE	STRUCTURAL ENG'S NAME AND SIGNATURE	BUILDER NAME AND SIGNATURE	DIGITAL SIGNATURE
SANTOSH KUMAR NAG GUNPC/ARC/0005/2018			