

Proposal Basic Information

Proposal File No.	GUNPC/0051/W02/2024
Owner Name	JALESHWAR SINGH
Khata No	1
Plot No	392
Village Name	Dundurya
Use	Residential
SubUse	Residential Bldg/Apartment

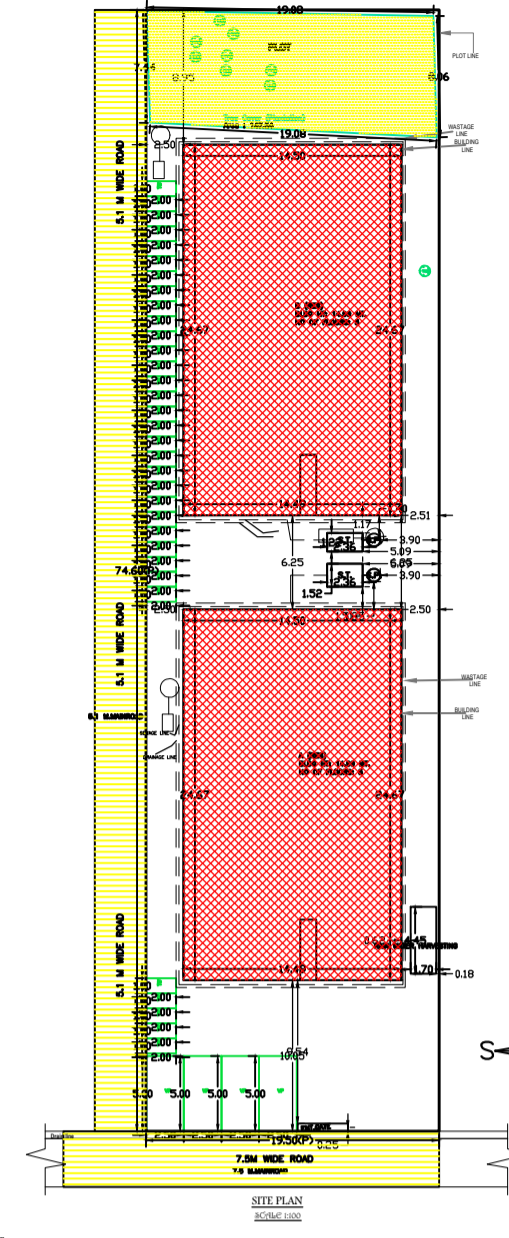
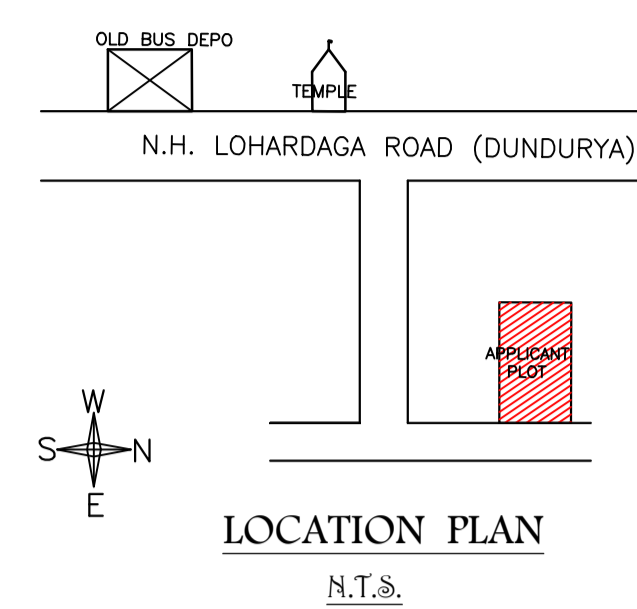
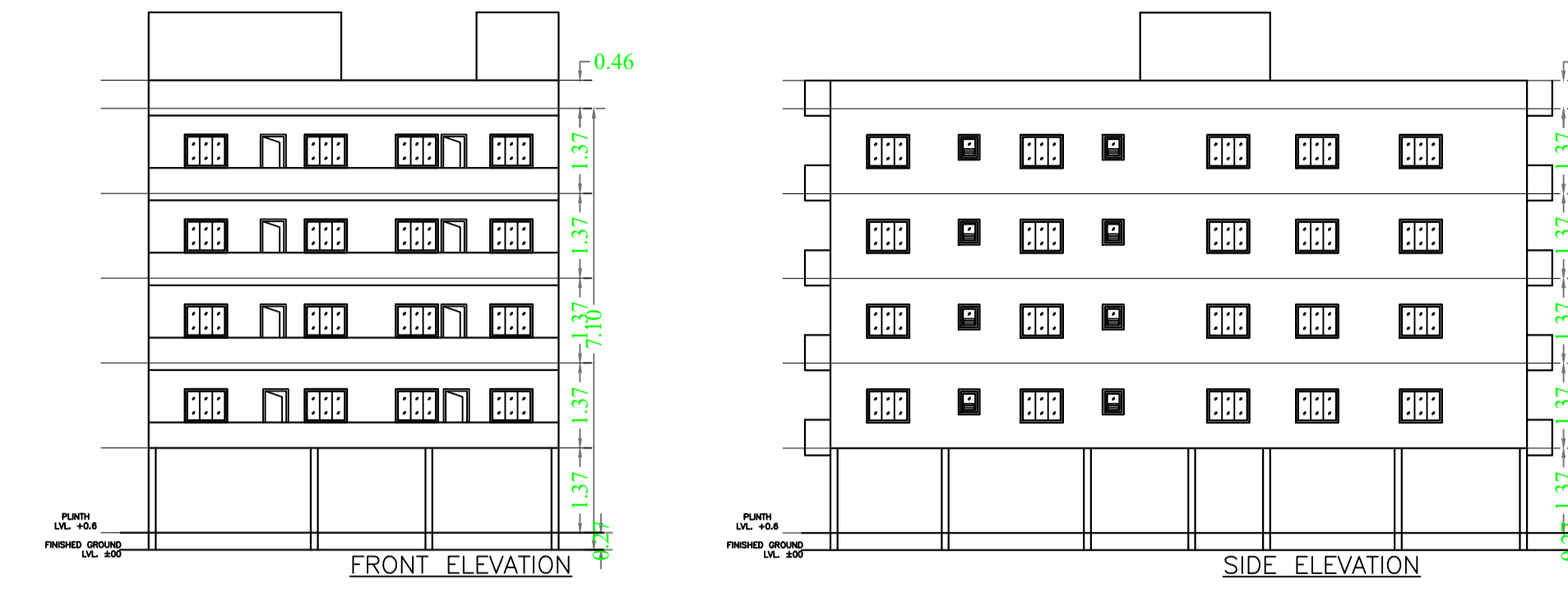
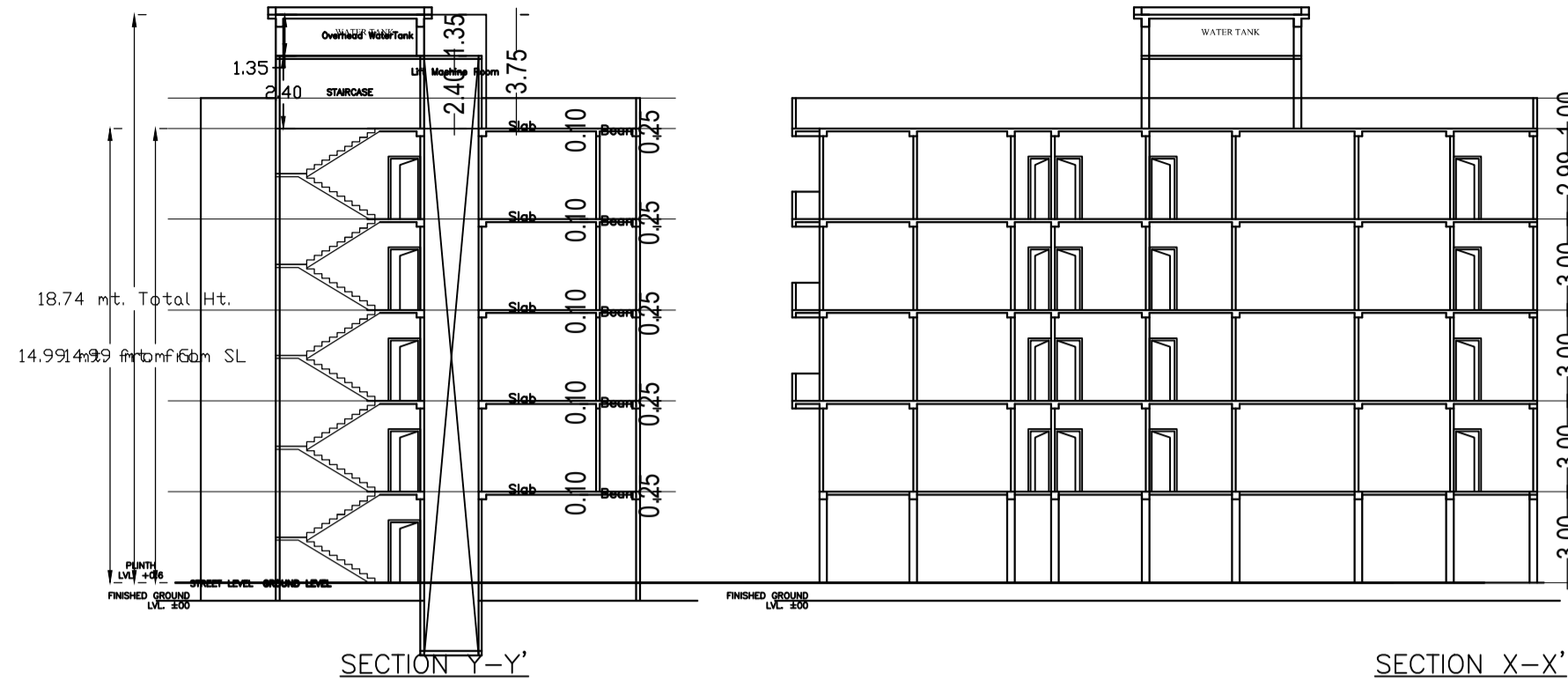

SCHEDULE OF DOOR:

Sl. No.	Material	Quantity	Unit
1	Wooden Door	10	Sq. Mtr.
2	Aluminum Door	5	Sq. Mtr.

SCHEDULE OF WINDOW/VENTILATION:

Sl. No.	Material	Quantity	Unit
1	Wooden Window	20	Sq. Mtr.
2	Aluminum Window	10	Sq. Mtr.

FAR & Tenement Details (Table 4c-1)

Sl. No.	Total FAR	Permitted FAR	Excess FAR	Permitted FAR	Excess FAR
1	100.00	100.00	0.00	100.00	0.00
2	100.00	100.00	0.00	100.00	0.00

Balcony Calculations Table

Sl. No.	Area	Volume	Total Area	Total Volume
1	10.00	15.00	10.00	15.00
2	10.00	15.00	10.00	15.00

Buildingwise Floor FAR Details

Floor Name	Area	Volume	Total Area	Total Volume
Ground Floor	100.00	150.00	100.00	150.00
1st Floor	100.00	150.00	100.00	150.00
2nd Floor	100.00	150.00	100.00	150.00
3rd Floor	100.00	150.00	100.00	150.00

Building -A (RES)

Sl. No.	Total FAR	Permitted FAR	Excess FAR	Permitted FAR	Excess FAR
1	100.00	100.00	0.00	100.00	0.00
2	100.00	100.00	0.00	100.00	0.00

UnitBIA Table for Building -B (RES)

Sl. No.	Total FAR	Permitted FAR	Excess FAR	Permitted FAR	Excess FAR
1	100.00	100.00	0.00	100.00	0.00
2	100.00	100.00	0.00	100.00	0.00

Balcony Calculations Table

Sl. No.	Area	Volume	Total Area	Total Volume
1	10.00	15.00	10.00	15.00
2	10.00	15.00	10.00	15.00

SCHEDULE OF DOOR:

Sl. No.	Material	Quantity	Unit
1	Wooden Door	10	Sq. Mtr.
2	Aluminum Door	5	Sq. Mtr.

SCHEDULE OF WINDOW/VENTILATION:

Sl. No.	Material	Quantity	Unit
1	Wooden Window	20	Sq. Mtr.
2	Aluminum Window	10	Sq. Mtr.

Building -B (RES)

Sl. No.	Total FAR	Permitted FAR	Excess FAR	Permitted FAR	Excess FAR
1	100.00	100.00	0.00	100.00	0.00
2	100.00	100.00	0.00	100.00	0.00

UnitBIA Table for Building -A (RES)

Sl. No.	Total FAR	Permitted FAR	Excess FAR	Permitted FAR	Excess FAR
1	100.00	100.00	0.00	100.00	0.00
2	100.00	100.00	0.00	100.00	0.00

Parking Check (Table 7b)

Vehicle Type	No.	Area	Volume
Car	10	100.00	150.00
Motorcycle	5	50.00	75.00

Required Parking (Table 7a)

Vehicle Type	No.	Area	Volume
Car	10	100.00	150.00
Motorcycle	5	50.00	75.00

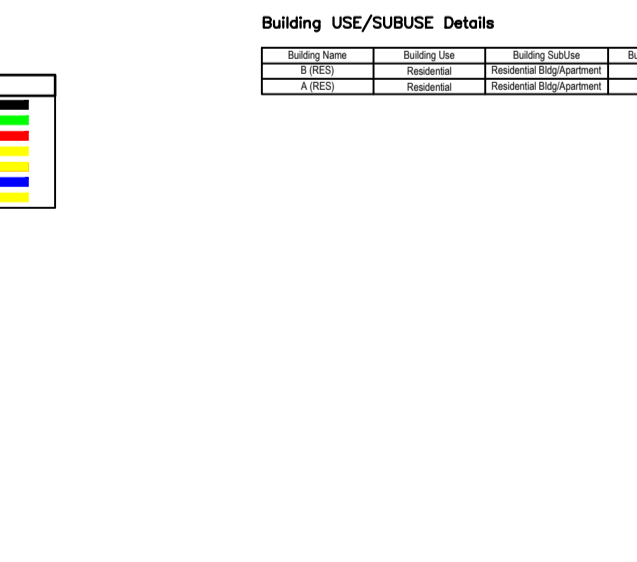
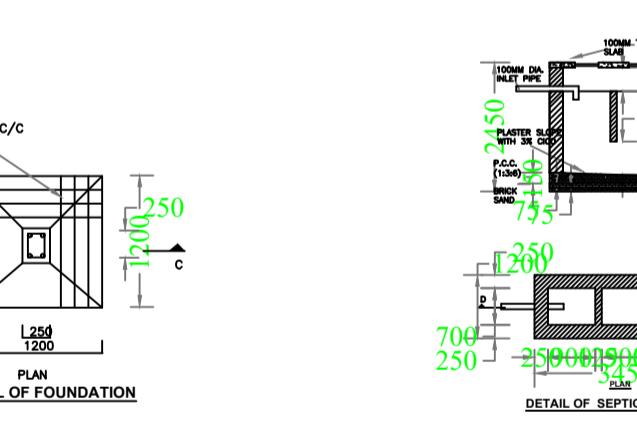
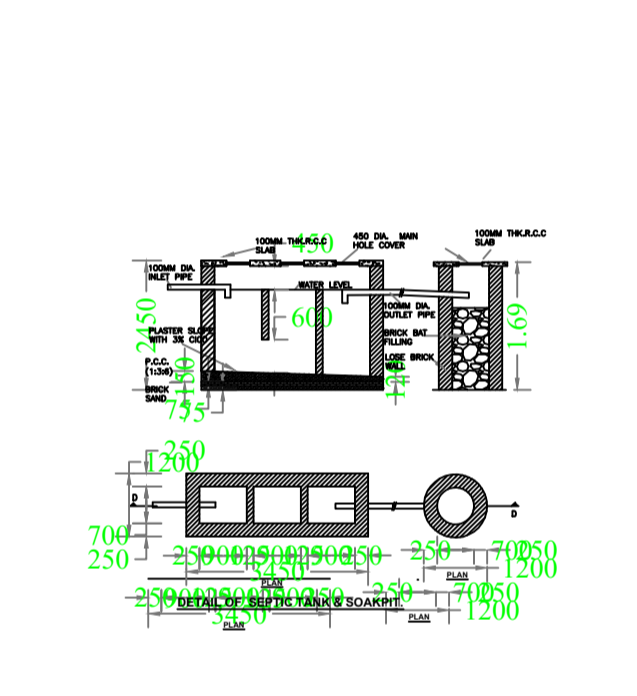
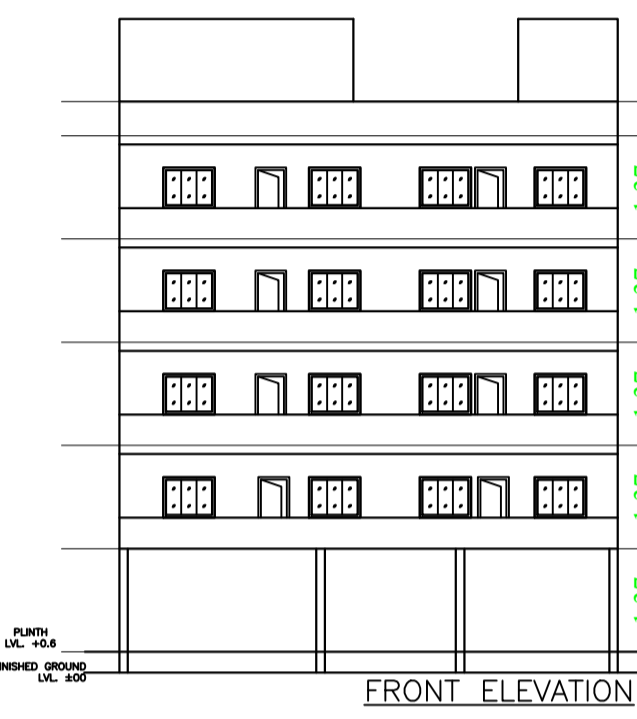
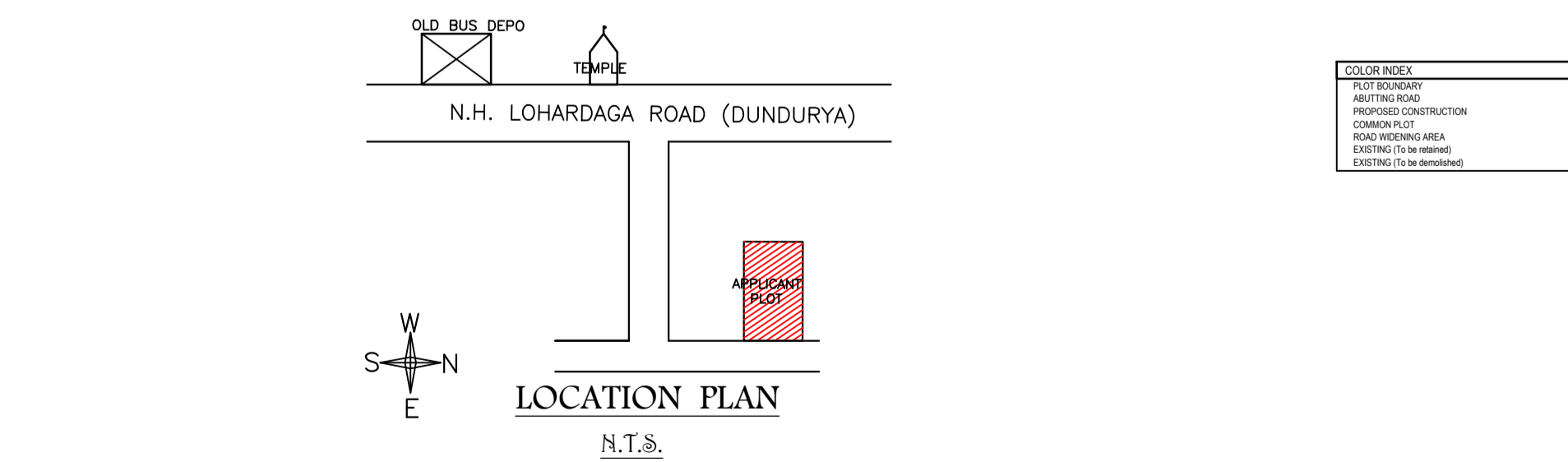
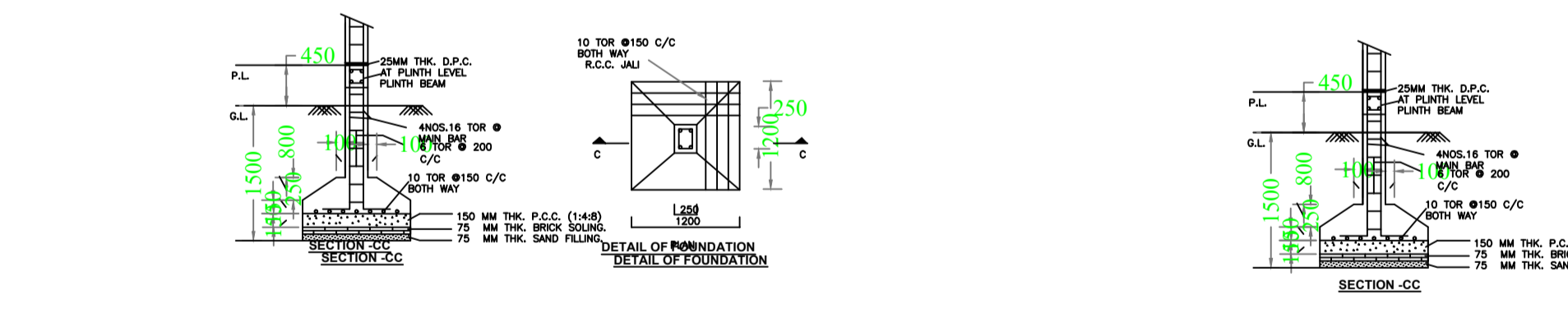
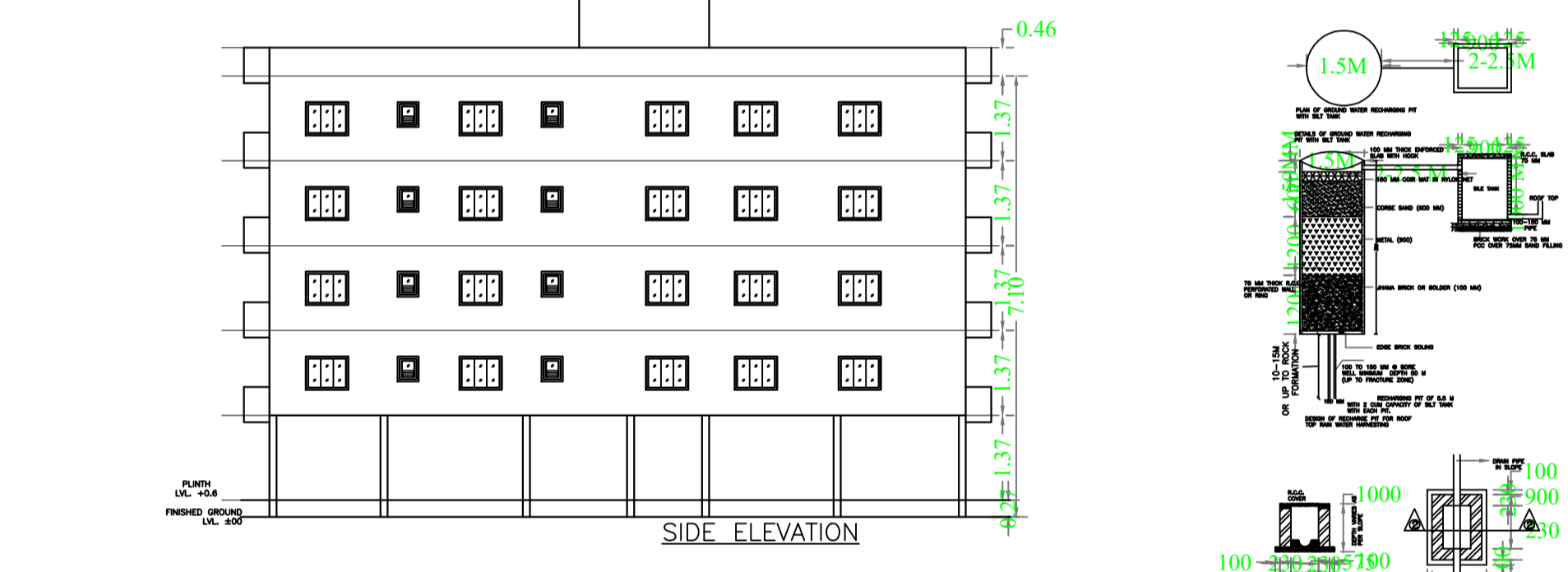
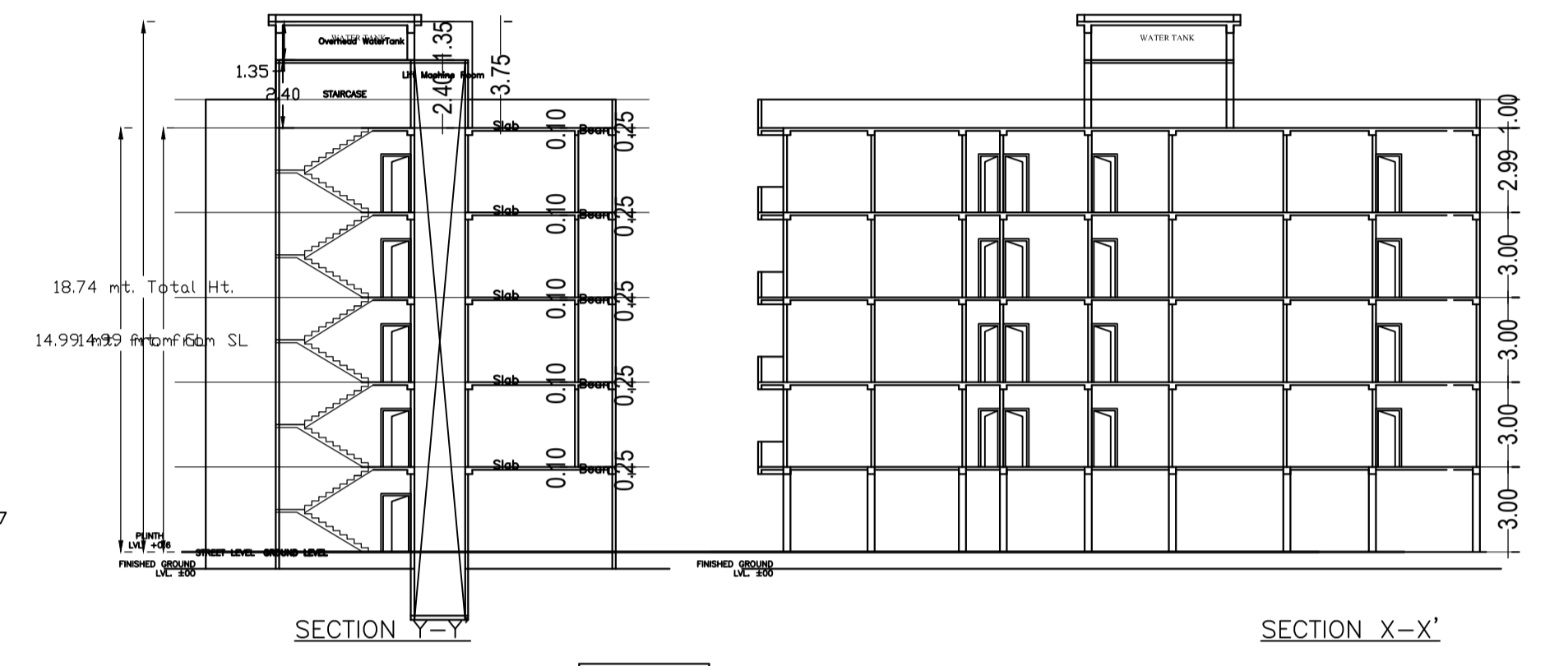
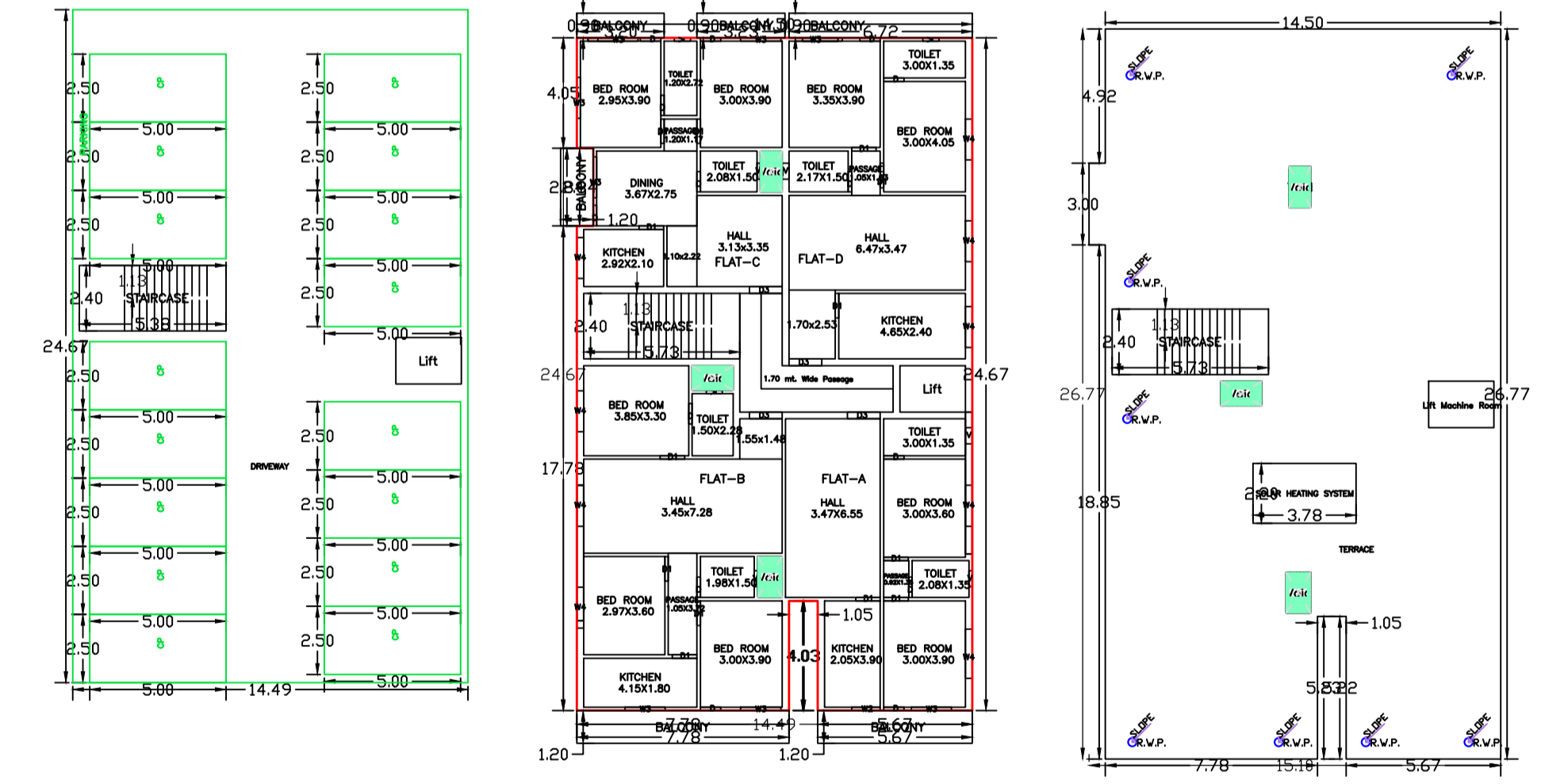
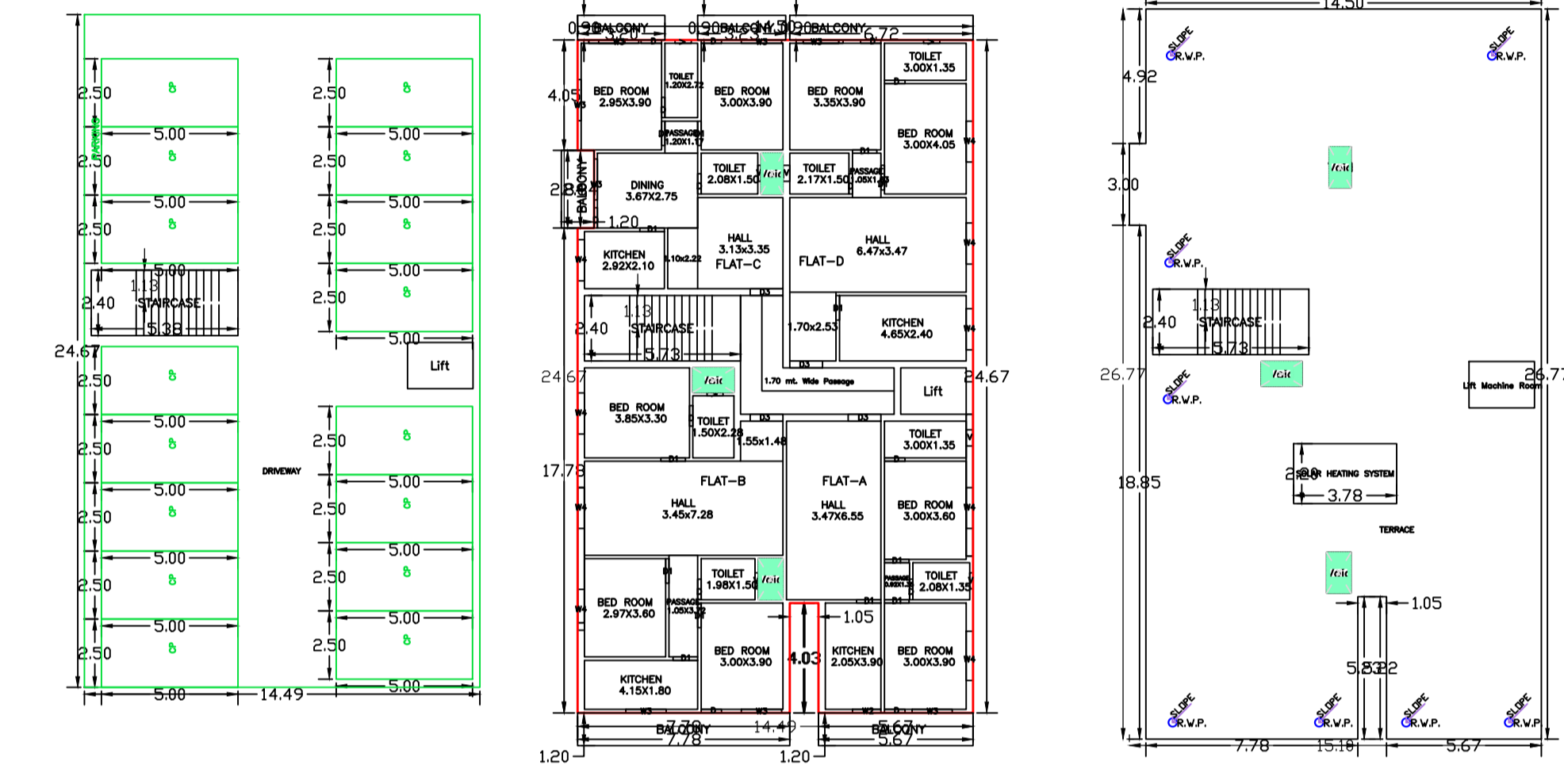

Building USE/SUBUSE Details

Building Use	Building Sub-Use	Building Structure	Building System
Residential	Residential	Residential	Residential

COLOR INDEX

Color	Meaning
Green	PROPOSED CONSTRUCTION
Yellow	EXISTING CONSTRUCTION
Red	EXISTING TO BE MAINTAINED