

Proposal Basic Information

Proposal File No.	GUNPC/BP/0057/W20/2024
Owner Name	BINOD KUMAR AGARWAL
Khata No	124,14
Plot No	966,963
Village Name	D.S.P Road
Use	Mixed
SubUse	Res+Comm

Building :A (BINOD KUMAR AGRAWAL)

Floor Name	Total Built Up Area (Sq.mt.)	Existing Built Up Area (Sq.mt.)	Proposed Built Up Area (Sq.mt.)	Deductions (Area in Sq.mt.)	Existing FAR Area (Sq.mt.)	Proposed FAR Area (Sq.mt.)	Total FAR Area (Sq.mt.)	Total Consumed Additional FAR Area (Sq.mt.)	Trmt (No.)
Ground Floor	113.28	113.28	0.00	0.00	113.28	0.00	113.28	113.28	01
First Floor	124.90	119.09	5.81	6.78	112.31	0.00	112.31	112.31	01
Second Floor	124.90	119.09	5.81	6.78	112.31	0.00	112.31	112.31	01
Third Floor	124.90	0.00	124.90	6.78	5.81	0.00	112.31	112.31	00
Fourth Floor	124.90	0.00	124.90	6.78	5.81	0.00	112.31	112.31	00
Terrace Floor	0.00	0.00	0.00	0.00	0.00	0.00	0.00	0.00	00
Total	612.88	351.46	261.42	27.12	23.24	337.90	224.62	562.52	03

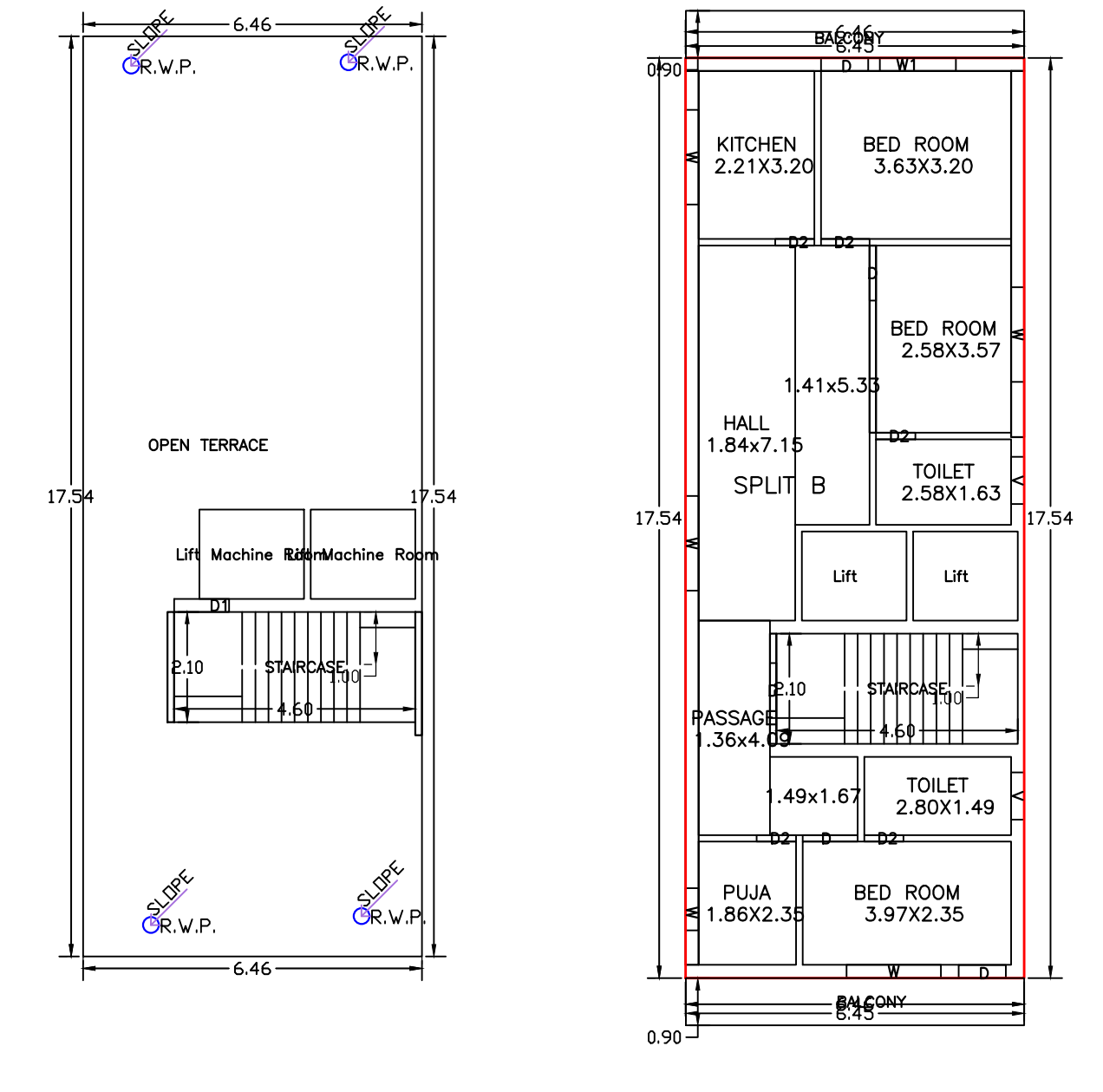
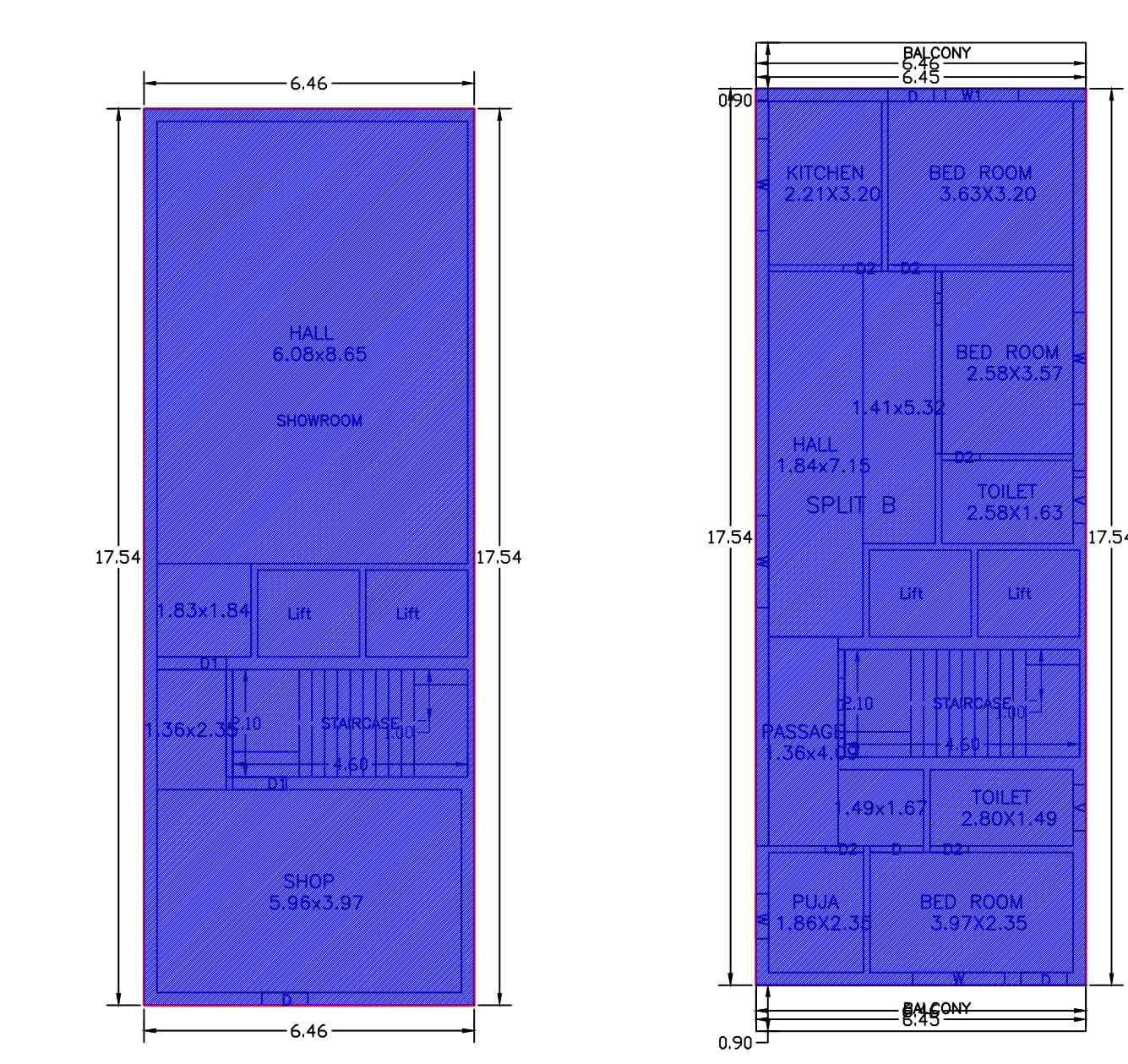

Required Parking (Table 7a)

Building Name	Type	SubUse	Area (Sq.mt.)	Units		Car		Visitors Car		TwoWheeler	
				Reqd.	Prop.	Reqd./Unit	Prop.	Reqd./Unit	Prop.	Reqd./Unit	Prop.
A (BINOD KUMAR AGRAWAL)	Residential	Residential Bldg/Apartment	>0	1	2.00	1	2	-	-	-	-
A (BINOD KUMAR AGRAWAL)	Residential	Residential Bldg/Apartment	>0	1	2.00	-	-	-	-	1	2
A (BINOD KUMAR AGRAWAL)	Residential	Residential Bldg/Apartment	>0	1	2.00	-	-	-	1	1	-
Total:				-	-	-	2	2	1	1	2

Parking Check (Table 7b)

Vehicle Type	No.	Area	No.	Area
Car	-	-	2	25.00
Visitor's Car Parking	-	-	1	12.50
Total Visitor Parking	1	12.50	1	12.50
TwoWheeler	-	-	2	4.00
Total TwoWheeler	2	4.00	2	4.00
Total		41.50		45.50

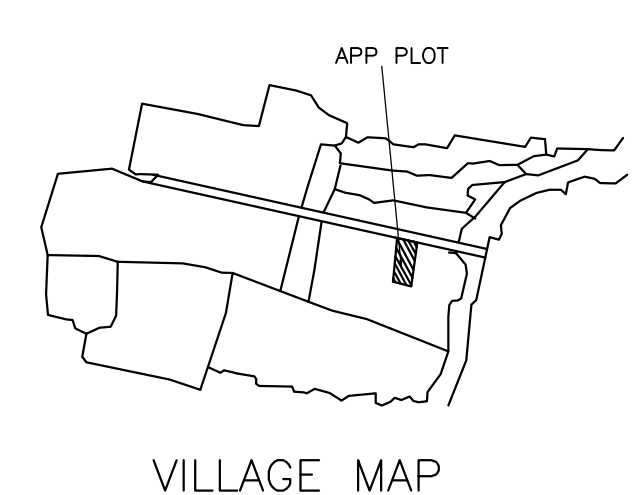
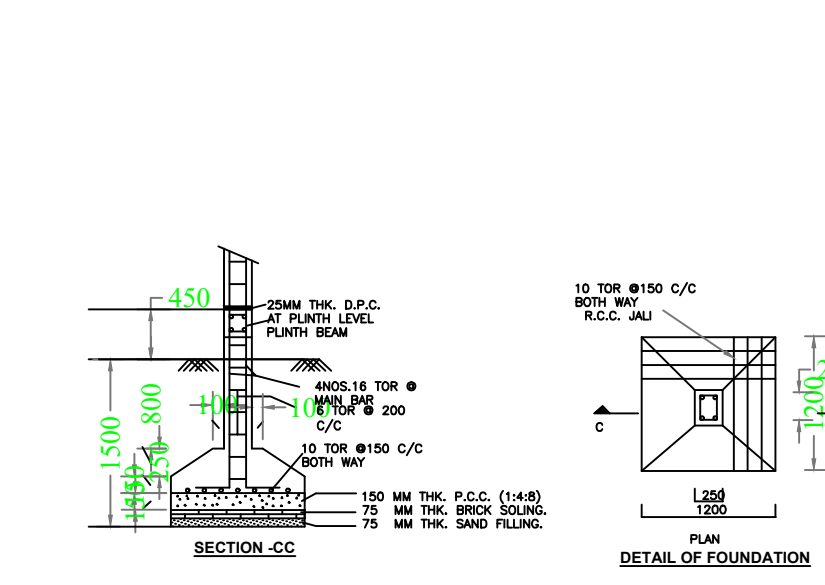
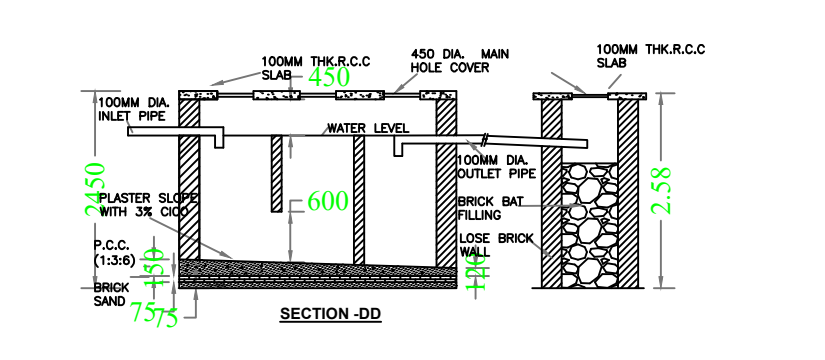
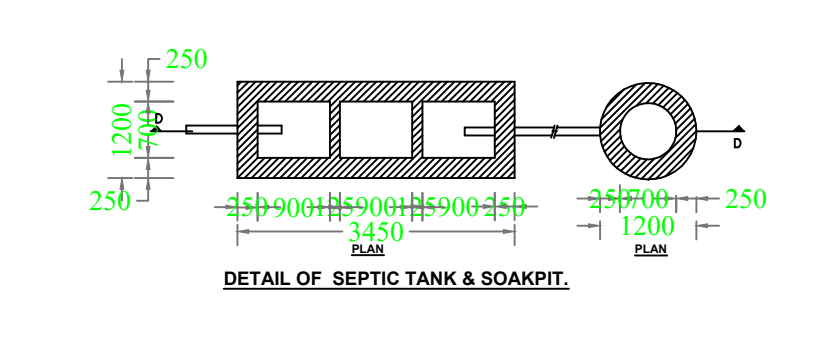

SCHEDULE OF DOOR:

BUILDING NAME	NAME	LENGTH	HEIGHT	NOS
A (BINOD KUMAR AGRAWAL)	D2	0.75	2.10	16
A (BINOD KUMAR AGRAWAL)	D	0.90	2.10	09
A (BINOD KUMAR AGRAWAL)	D2	0.92	2.10	02
A (BINOD KUMAR AGRAWAL)	D2	0.93	2.10	02
A (BINOD KUMAR AGRAWAL)	D	1.05	2.10	12
A (BINOD KUMAR AGRAWAL)	D1	1.05	2.10	01
A (BINOD KUMAR AGRAWAL)	D1	1.36	2.10	01

SCHEDULE OF WINDOW/VENTILATION:

BUILDING NAME	NAME	LENGTH	HEIGHT	NOS
A (BINOD KUMAR AGRAWAL)	W	0.80	1.20	02
A (BINOD KUMAR AGRAWAL)	W	0.88	1.20	02
A (BINOD KUMAR AGRAWAL)	V	0.90	1.20	08
A (BINOD KUMAR AGRAWAL)	W1	1.43	1.20	02
A (BINOD KUMAR AGRAWAL)	W1	1.45	1.20	02
A (BINOD KUMAR AGRAWAL)	W	1.80	1.20	16

AREA STATEMENT GUMLA NAGAR PARIASHAD

AREA DETAILS	AREA (SQ.MT.)	SO.MT.
AREA OF PLOT (Minimum)	(A)	282.04
NET AREA OF PLOT (Gross Plot Area - Deduction from Gross Plot Area)	(A-Deductions)	282.04
Deduction for Balance Plot Area (from Gross Plot Area)		
Common Plot	28.89	28.89
BALANCE AREA OF PLOT (Net Plot Area - Recreational/Amenity space)	(A-Deductions)	253.15
PLOT AREA FOR COVERAGE (Net Plot Area)	(A-Deductions)	282.04
Plot Area for FAR (Net Plot Area - Road/Widening Area)	(A-Deductions)	282.04
COVERAGE CHECK		
Permissible Coverage area (60.16 %)	169.22	
Proposed Coverage Area (40.16 %)	113.28	
Total Prop. Coverage Area (40.16 %)	113.28	
Balance coverage area (19.83 %)	55.94	
FAR CHECK		
Perm. FAR Area (2.000)	564.08	
Total Perm FAR area	564.08	
Residential FAR	446.23	
Commercial FAR	113.28	
Proposed FAR Area	562.52	
Total Proposed FAR Area	562.52	
Consumed FAR (Factor)	1.99	
Balance FAR Area	1.56	
BUILT UP AREA CHECK		
Total Proposed BuiltUp Area	612.88	
ARCHITECT (Regd)	DEEPAK DIWAN	
ENGINEER (Regd)		
SUPERVISOR (Regd)		
OWNER (Regd)	BINOD KUMAR AGARWAL	
DEVELOPMENT AUTHORITY	LOCAL BODY	

Buildingwise Floor FAR Details

Floor Name	Building Name				Total			
	Proposed Built Up Area (Sq.mt.)	Existing Built Up Area (Sq.mt.)	Proposed FAR Area (Sq.mt.)	Existing FAR Area (Sq.mt.)	Total Proposed Built Up Area (Sq.mt.)	Total Existing Built Up Area (Sq.mt.)	Total FAR Area (Sq.mt.)	Total Existing FAR Area (Sq.mt.)
Ground Floor	0.00	113.28	0.00	113.28	0.00	113.28	0.00	113.28
First Floor	5.81	119.09	0.00	112.31	5.81	119.09	0.00	112.31
Second Floor	5.81	119.09	0.00	112.31	5.81	119.09	0.00	112.31
Third Floor	124.90	0.00	112.31	0.00	124.90	0.00	112.31	0.00
Fourth Floor	124.90	0.00	112.31	0.00	124.90	0.00	112.31	0.00
Terrace Floor	0.00	0.00	0.00	0.00	0.00	0.00	0.00	0.00
Total :	261.42	351.46	224.62	337.90	261.42	351.46	224.62	337.90

FAR & Tenement Details (Table 4c-1)

Building	No. of Same Bldg	Total Built Up Area (Sq.mt.)	Existing Built Up Area (Sq.mt.)	Proposed Built Up Area (Sq.mt.)	Deductions (Area in Sq.mt.)		Existing FAR Area (Sq.mt.)	Proposed FAR Area (Sq.mt.)	Total FAR Area (Sq.mt.)	Total Consumed Additional FAR Area (Sq.mt.)	Trmt (No.)
					Lift	Balcony					
A (BINOD KUMAR AGRAWAL)	1	612.88	351.46	261.42	27.12	23.24	337.90	224.62	562.52	562.52	03
Total	1	612.88	351.46	261.42	27.12	23.24	337.90	224.62	562.52	562.52	03

UnitBUA Table for Building :A (BINOD KUMAR AGRAWAL)

FLOOR	Name	UnitBUA Type	Entity Type	UnitBUA Area	Carpet Area	No. of Rooms	No. of Tenement
GROUND FLOOR PLAN	SHOWROOM	SHOP	Existing	106.50	106.24	2	1
TYPICAL - 1 & 2 FLOOR PLAN	SPLIT B	FLAT	Existing	354.35	295.07	9	2
TYPICAL - 3 & 4 FLOOR PLAN	SPLIT B	FLAT	Proposed	0.00	0.00	9	0
Total:	-	-	-	815.20	696.39	38	3

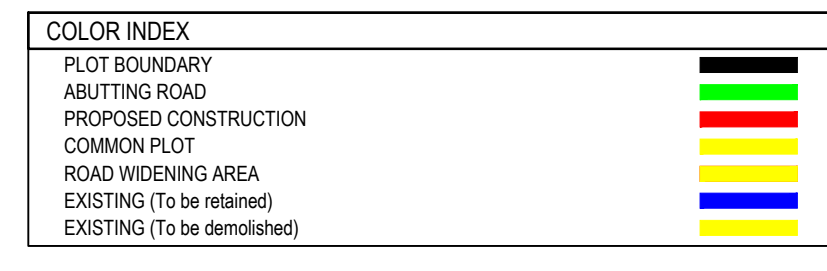

Balcony Calculations Table

FLOOR	SIZE	AREA	TOTAL AREA
TYPICAL - 1 & 2 FLOOR PLAN	0.90 X 6.45 X 2 X 2	23.24	23.24
Total	-	-	46.48

LTP NAME AND SIGNATURE	STRUCTURAL ENG'S NAME AND SIGNATURE	BUILDER NAME AND SIGNATURE	DIGITAL SIGNATURE
DEEPAK DIWAN GUNPC/ARC/0003/2017			