

Proposal Basic Information

Proposal File No.	GUNPC/BP/0039/W03/2024
Owner Name	MARY MINJ
Khata No	54
Plot No	1262
Village Name	Dundurya
Use	Residential
SubUse	Bungalow/ Dwelling / Non Apartment

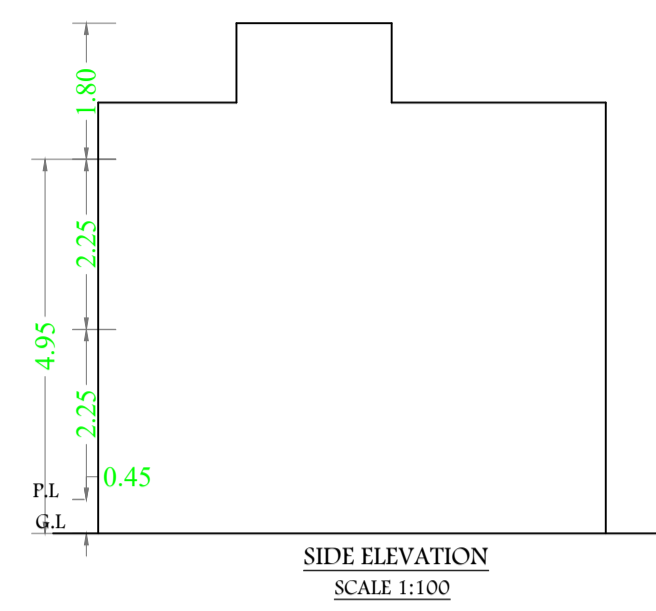
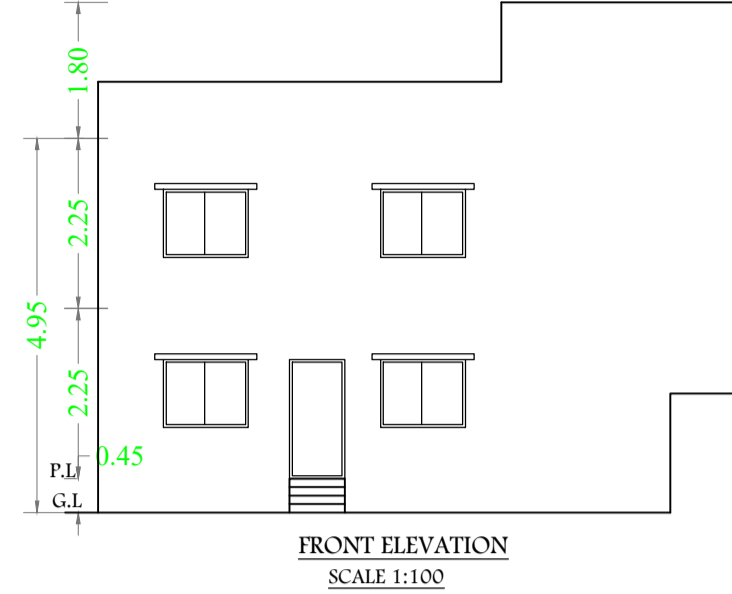
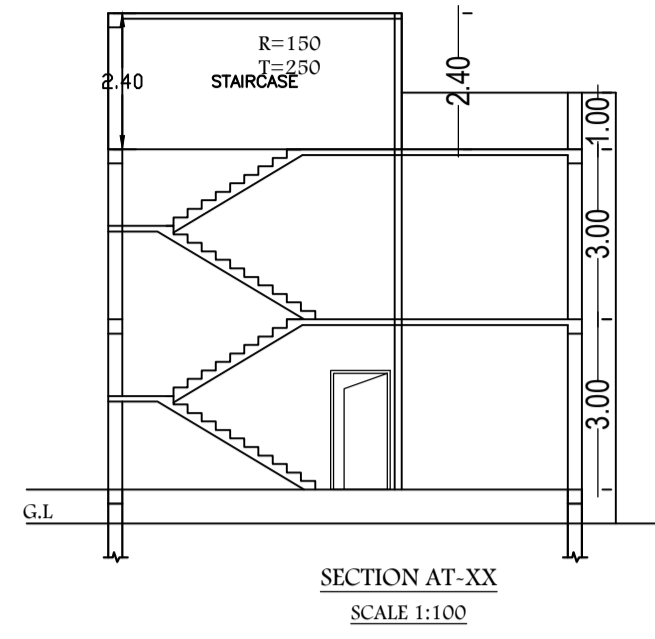
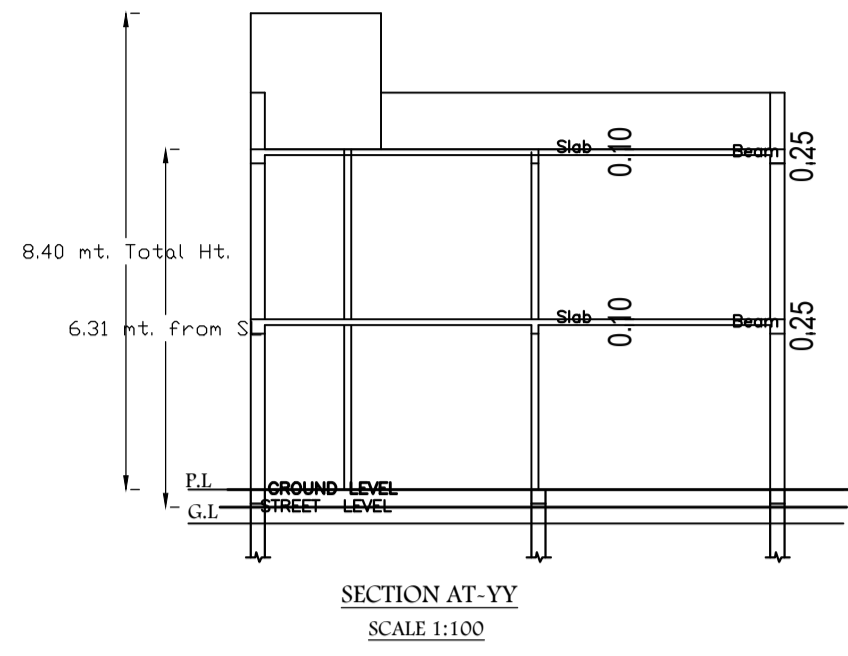

SCHEDULE OF DOOR:

BUILDING NAME	NAME	LENGTH	HEIGHT	NOS
A (MARY MINJ)	D1	0.90	2.10	02
A (MARY MINJ)	D2	0.96	2.10	02
A (MARY MINJ)	D3	1.05	2.10	02
A (MARY MINJ)	D4	1.15	2.10	02

SCHEDULE OF WINDOW/VENTILATION:

BUILDING NAME	NAME	LENGTH	HEIGHT	NOS
A (MARY MINJ)	W1	0.60	1.20	12
A (MARY MINJ)	W2	1.80	1.20	12
A (MARY MINJ)	W3	2.00	1.20	02

Building :A (MARY MINJ)

Floor Name	Total Built Up Area (Sq.mt.)	Proposed FAR Area (Sq.mt.)	Total FAR Area (Sq.mt.)	Total Consumed Additional FAR Area (Sq.mt.)	Trent (No.)
Ground Floor	91.41	91.41	91.41	91.41	01
First Floor	91.41	91.41	91.41	91.41	00
Terrace Floor	0.00	0.00	0.00	0.00	00
<b>Total</b>	<b>182.82</b>	<b>182.82</b>	<b>182.82</b>	<b>182.82</b>	<b>01</b>

Buildingwise Floor FAR Details

Floor Name	Building Name A (MARY MINJ)		Total Proposed Built Up Area (Sq.mt.)	Total FAR Area (Sq.mt.)
	Proposed Built Up Area (Sq.mt.)	Proposed FAR Area (Sq.mt.)		
Ground Floor	91.41	91.41	91.41	91.41
First Floor	91.41	91.41	91.41	91.41
Terrace Floor	0.00	0.00	0.00	0.00
<b>Total</b>	<b>182.82</b>	<b>182.82</b>	<b>182.82</b>	<b>182.82</b>

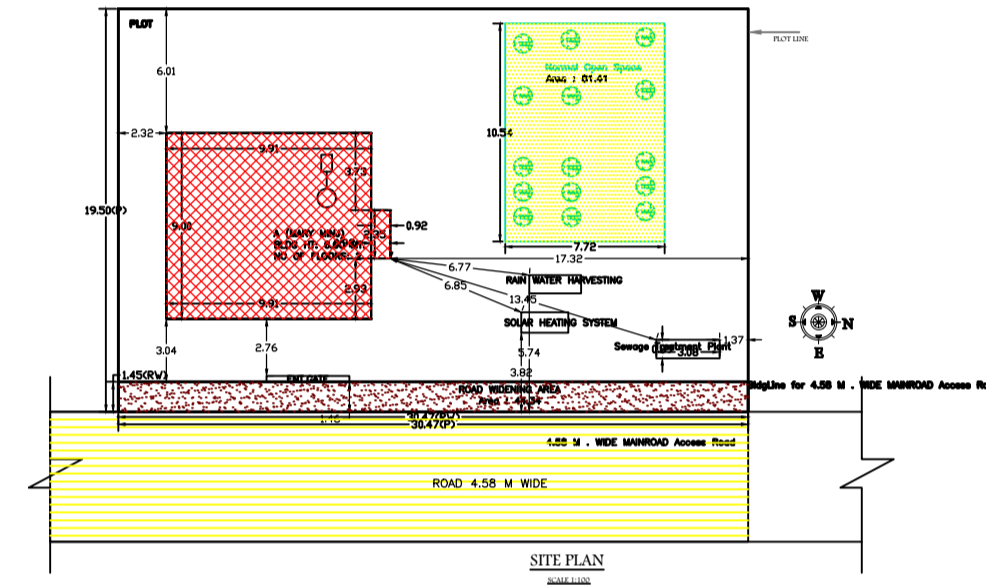
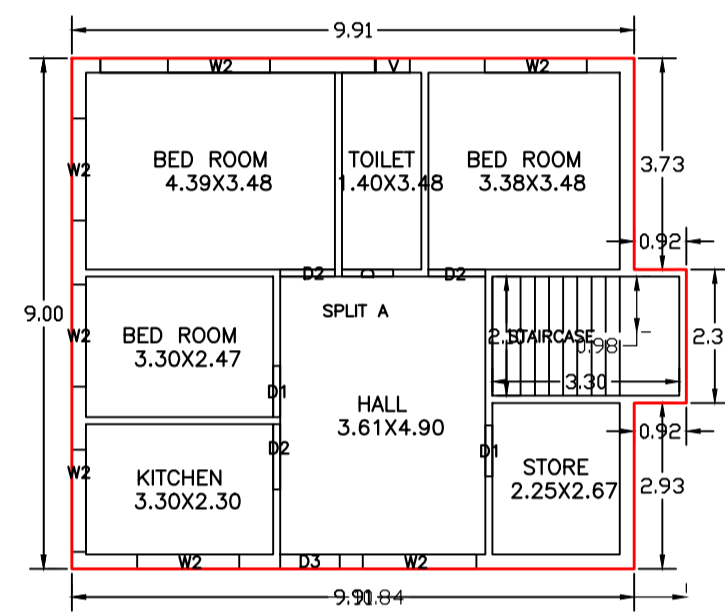
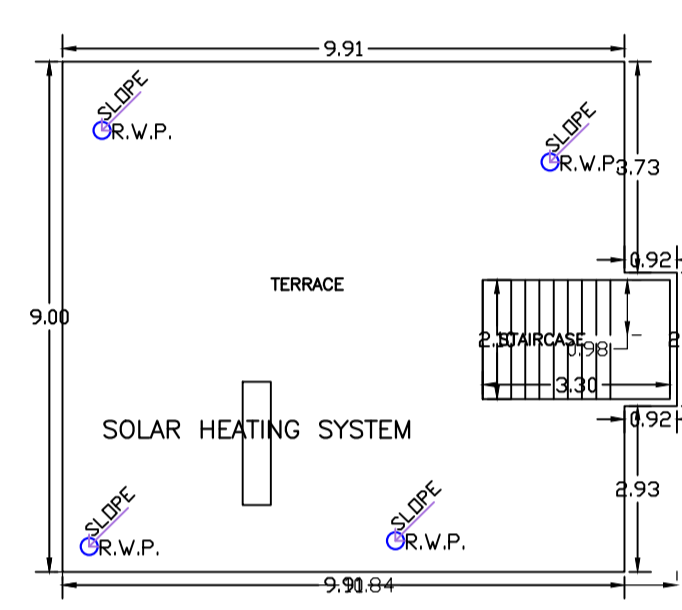
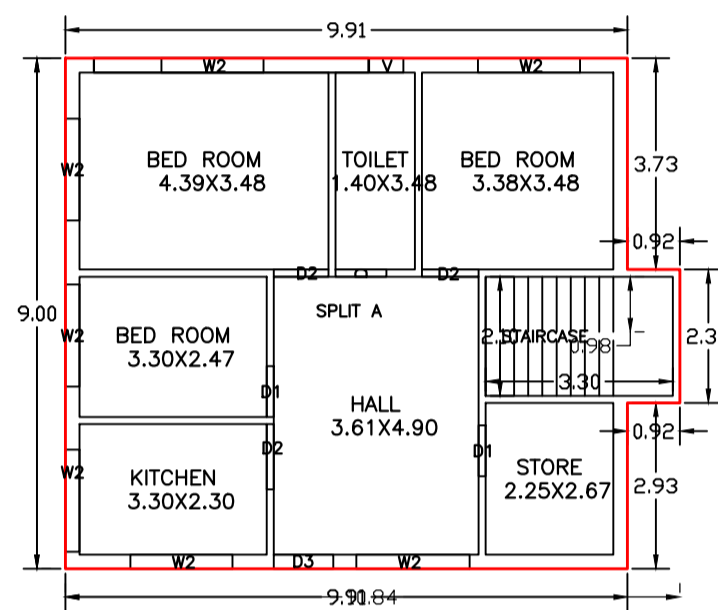

GROUND FLOOR PLAN (Proposed) (SCALE 1:100)

TERRACE FLOOR PLAN (SCALE 1:100)

FIRST FLOOR PLAN (Proposed) (SCALE 1:100)

SITE PLAN

AREA STATEMENT GUMLA		VERSION NO. : 1.0.70
NAGAR PANSKAD		VERSION DATE: 18/10/2020
PROJECT DETAILS		
Region : JHARKHAND URBAN LOCAL BODIES	Plot Use: Residential	
District: GUMLA	Plot SubUse: Bungalow/ Dwelling / Non Apartment	
Authority: GUMLA NAGAR PANSKAD	Plot/Nearby/Religious/Structure: NA	
Township No: GUNPC/BP/0039/W03/2024	Plot/SubPlot No: 1262	
Application Type: General Proposal	North -	
Project Type: Building Permission	South -	
Nature of Development: New	East -	
Location of Development Area: Old Area	West -	
AREA DETAILS:		
AREA OF PLOT (Minimum)	(A)	594.26
Deduction for Net Plot Area		44.34
Road Widening Area		44.34
<b>Total</b>		<b>125.75</b>
NET AREA OF PLOT (Gross Plot Area - Deduction from Gross Plot Area)	(A-Deductions)	549.92
Deduction for Balance Plot Area (from Gross Plot Area)		44.34
Road Widening Area		44.34
<b>Total</b>		<b>81.41</b>
BALANCE AREA OF PLOT (Net Plot Area - Recreational/Amenity space)	(A-Deductions)	468.51
PLOT AREA FOR COVERAGE (Net Plot Area)	(A-Deductions)	549.92
Plot Area for FAR (Net Plot Area + Road Widening Area)	(A-Deductions)	549.92
COVERAGE CHECK:		
Permissible Coverage area (60.00 %)		329.95
Proposed Coverage Area (16.62 %)		91.41
<b>Total Prop. Coverage Area (16.62 %)</b>		<b>91.41</b>
Balance coverage area (43.38 %)		238.54
FAR CHECK:		
Perm. FAR Area (1.500)		824.88
<b>Total Perm. FAR area</b>		<b>824.88</b>
Residential FAR		182.81
<b>Proposed FAR Area</b>		<b>182.81</b>
<b>Total Proposed FAR Area</b>		<b>182.81</b>
Consumed FAR (Factor)		0.33
Balance FAR Area		642.07
BUILT UP AREA CHECK:		
<b>Total Proposed Builtup Area</b>		<b>182.82</b>
ARCHITECT (Reggt): DEEPAK DIWAN		
ENGINEER (Reggt):		
SUPERVISOR (Reggt):		
OWNER (Reggt): MARY MINJ		
DEVELOPMENT AUTHORITY		LOCAL BODY

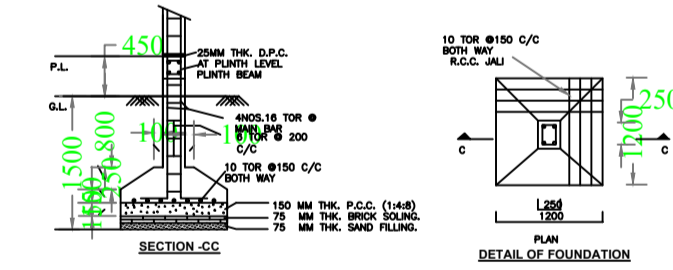
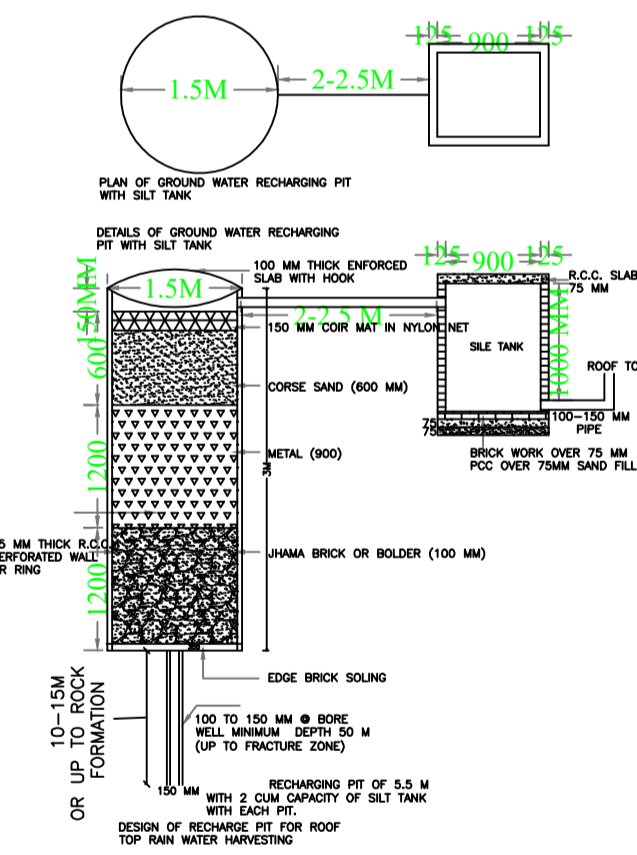
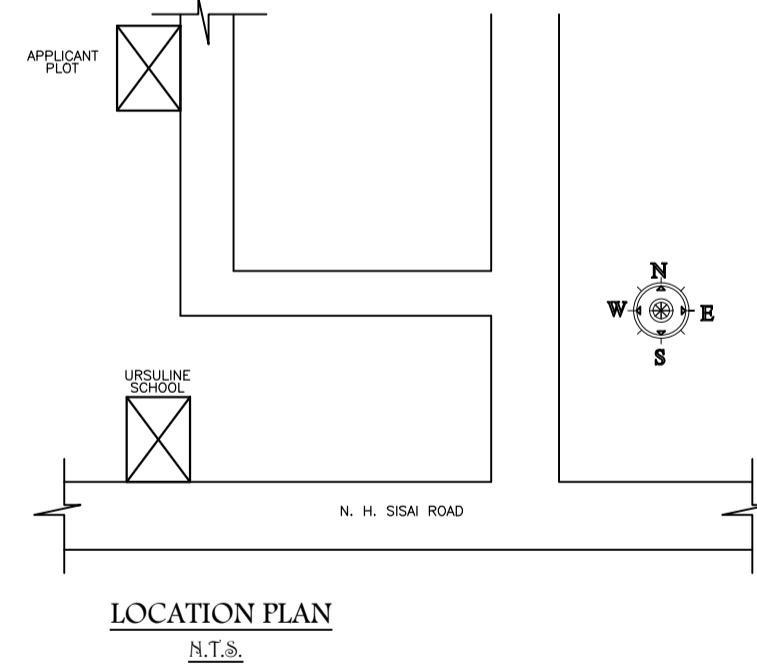
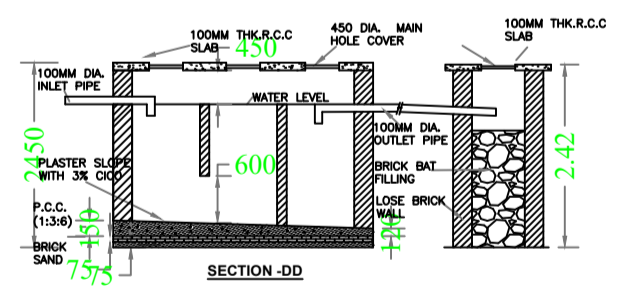
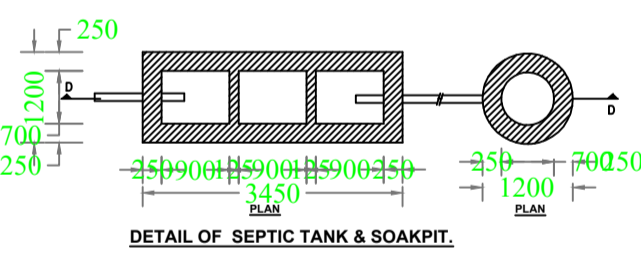

UnitBUA Table for Building :A (MARY MINJ)

FLOOR	Name	UnitBUA Type	UnitBUA Area	Carpet Area	No. of Rooms	No. of Tenement
GROUND FLOOR PLAN	SPLIT A	FLAT	182.81	180.39	7	1
FIRST FLOOR PLAN	SPLIT A	FLAT	0.00	0.00	7	0
<b>Total</b>	-	-	<b>182.81</b>	<b>180.39</b>	<b>14</b>	<b>1</b>

Building USE/SUBUSE Details

Building Name	Building Use	Building SubUse	Building Structure
A (MARY MINJ)	Residential	Bungalow/ Dwelling / Non Apartment	Non-Highrise

COLOR INDEX

PLOT BOUNDARY	[Red Line]
ABUTTING ROAD	[Green Line]
PROPOSED CONSTRUCTION	[Yellow Line]
COMMON PLOT	[Blue Line]
ROAD WIDENING AREA	[Orange Line]
EXISTING (To be retained)	[Grey Line]
EXISTING (To be demolished)	[Black Line]

FAR & Tenement Details (Table 4c-1)

Building	No. of Same Bldg	Total Built Up Area (Sq.mt.)	Proposed FAR Area (Sq.mt.)	Total FAR Area (Sq.mt.)	Total Consumed Additional FAR Area (Sq.mt.)	Trent (No.)
A (MARY MINJ)	1	182.82	182.82	182.82	182.82	01
<b>Grand Total :</b>	<b>1</b>	<b>182.82</b>	<b>182.82</b>	<b>182.82</b>	<b>182.82</b>	<b>01</b>

LTP NAME AND SIGNATURE	STRUCTURAL ENG'S NAME AND SIGNATURE	BUILDER NAME AND SIGNATURE	DIGITAL SIGNATURE
DEEPAK DIWAN GUNPC/ARC/0003/2017			