

Proposal Basic Information	
Proposal File No.	GUNPC/BI/0019/W03/2024
Owner Name	SUDHIR KUMAR
Khata No	2
Plot No	216
Village Name	Dundurya
Use	Residential
SubUse	Bungalow/ Dwelling / Non Apartment

UnitBUA Table for Building :SUDHIR KUMAR (A BUILDING)

FLOOR	Name	UnitBUA Type	UnitBUA Area	Carpet Area	No. of Rooms	No. of Tenement
GROUND FLOOR PLAN	SPLIT a	FLAT	100.77	100.66	5	1
FIRST FLOOR PLAN	SPLIT a	FLAT	0.00	0.00	5	0
SECOND FLOOR PLAN	SPLIT a	FLAT	0.00	0.00	5	0
Total:	-	-	100.77	100.66	15	1

SCHEDULE OF DOOR:

BUILDING NAME	NAME	LENGTH	HEIGHT	NOS
SUDHIR KUMAR (A BUILDING)	D1	0.76	2.10	03
SUDHIR KUMAR (A BUILDING)	D	1.07	2.10	09

SCHEDULE OF WINDOW/VENTILATION:

BUILDING NAME	NAME	LENGTH	HEIGHT	NOS
SUDHIR KUMAR (A BUILDING)	V	0.60	1.20	03
SUDHIR KUMAR (A BUILDING)	W	0.91	1.20	03
SUDHIR KUMAR (A BUILDING)	W	1.22	1.20	06

Building :SUDHIR KUMAR (A BUILDING)

Floor Name	Total Built Up Area (Sq.mt.)	Proposed FAR Area (Sq.mt.)	Total FAR Area (Sq.mt.)	Total Consumed Additional FAR Area (Sq.mt.)	Tnmt (No.)
Ground Floor	51.34	51.34	51.34	51.34	01
First Floor	51.50	51.50	51.50	51.50	00
Second Floor	46.92	46.92	46.92	46.92	00
Terrace Floor	0.00	0.00	0.00	0.00	00
Total :	149.76	149.76	149.76	149.76	01
Total Number of Same Buildings :	1				
Total :	149.76	149.76	149.76	149.76	01

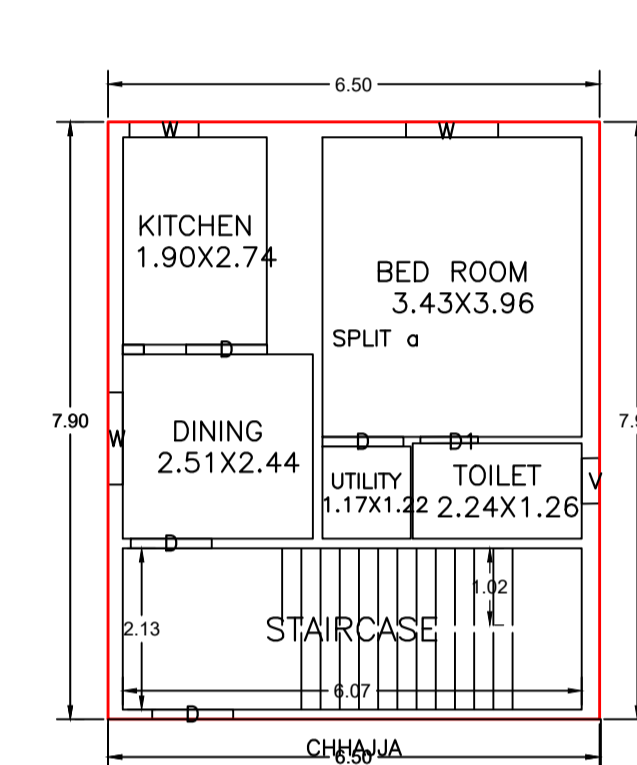

GROUND FLOOR PLAN (Proposed) (SCALE 1:100)

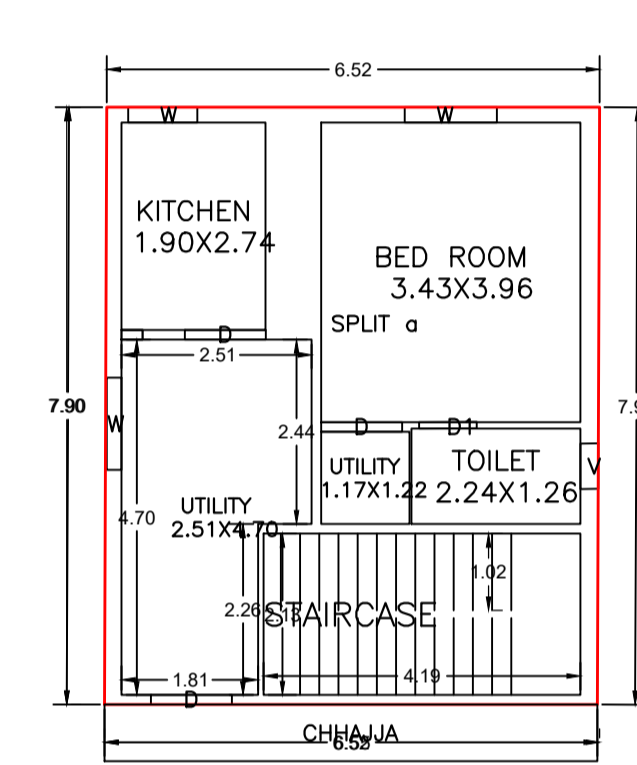

FIRST FLOOR PLAN (Proposed) (SCALE 1:100)

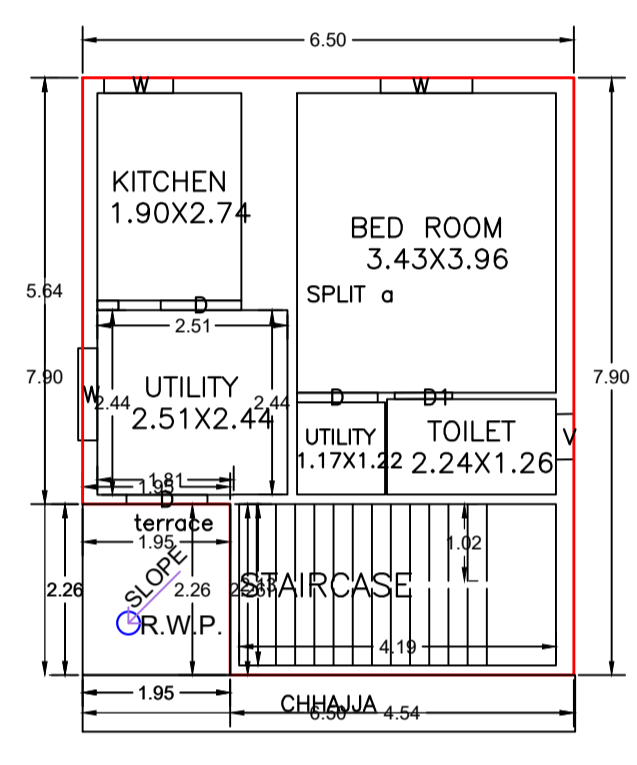

SECOND FLOOR PLAN (Proposed) (SCALE 1:100)

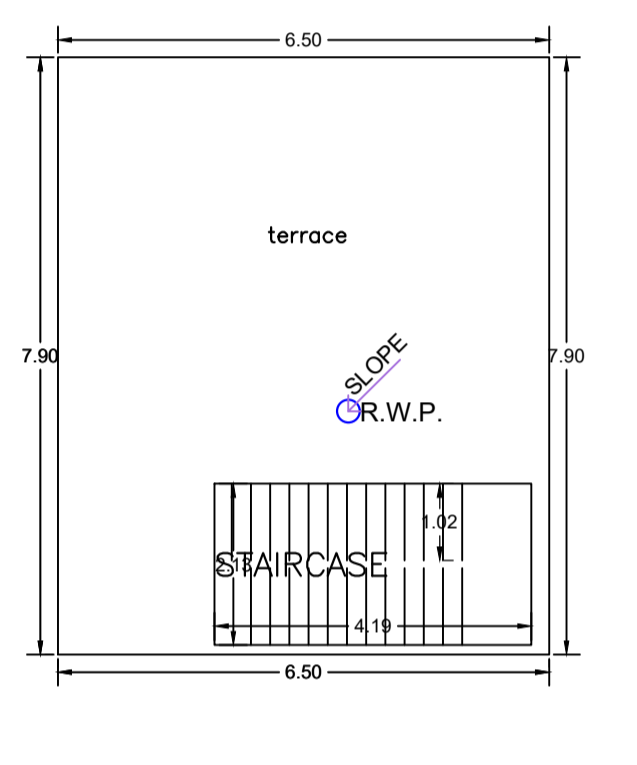

TERRACE FLOOR PLAN (SCALE 1:100)

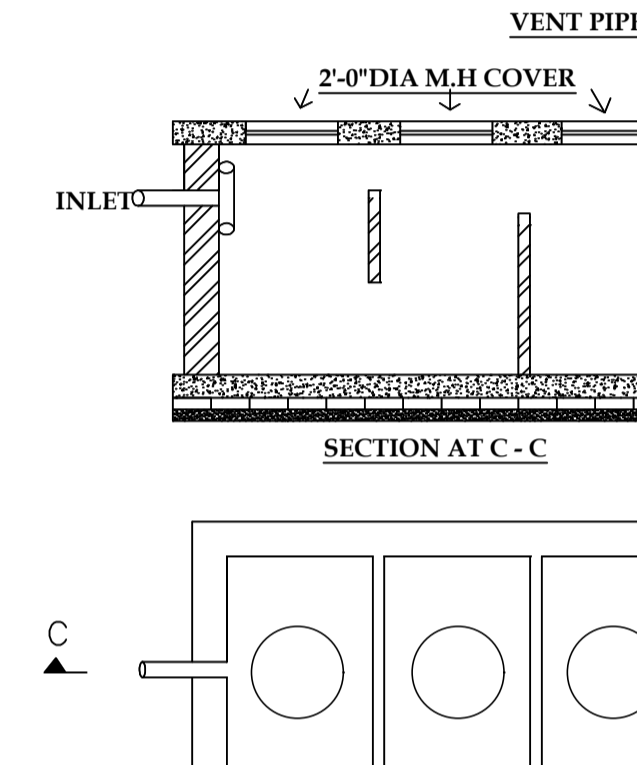

PLAN DET. OF SEPTIC TANK (SCALE = 1:48)

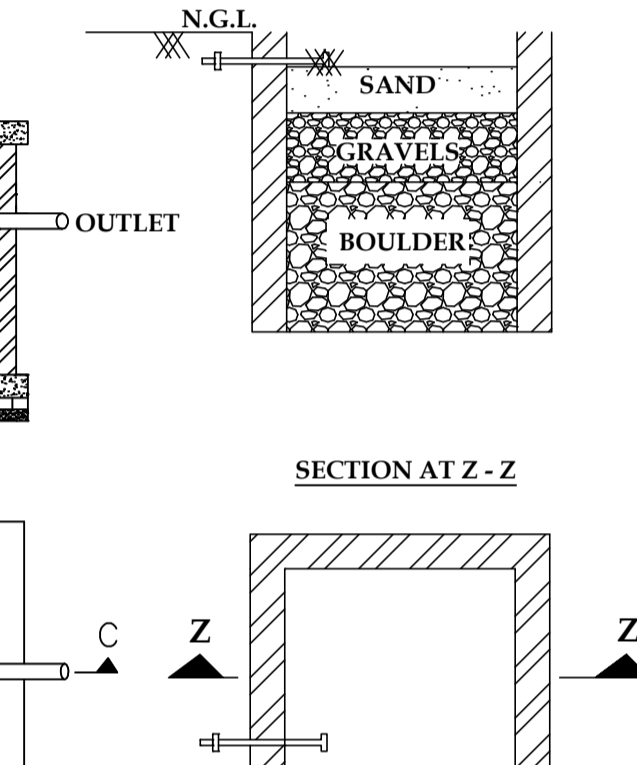

R.W.H PLAN (SCALE - 1 : 48)

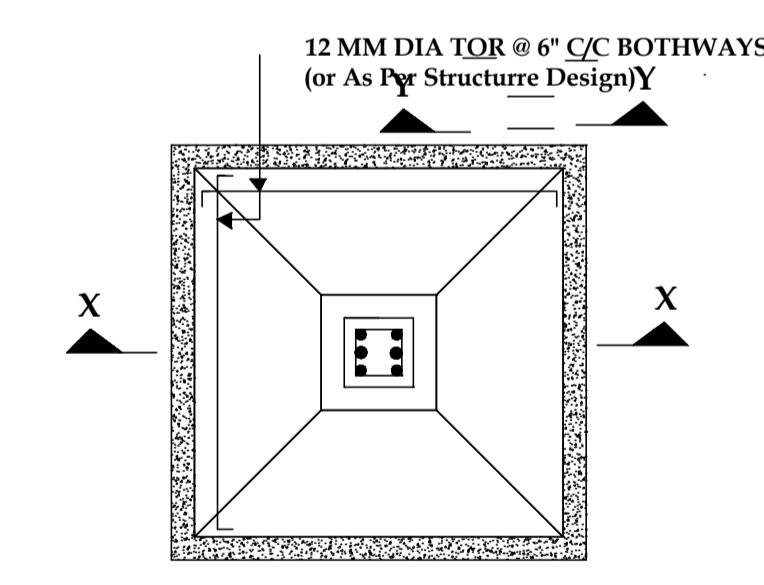
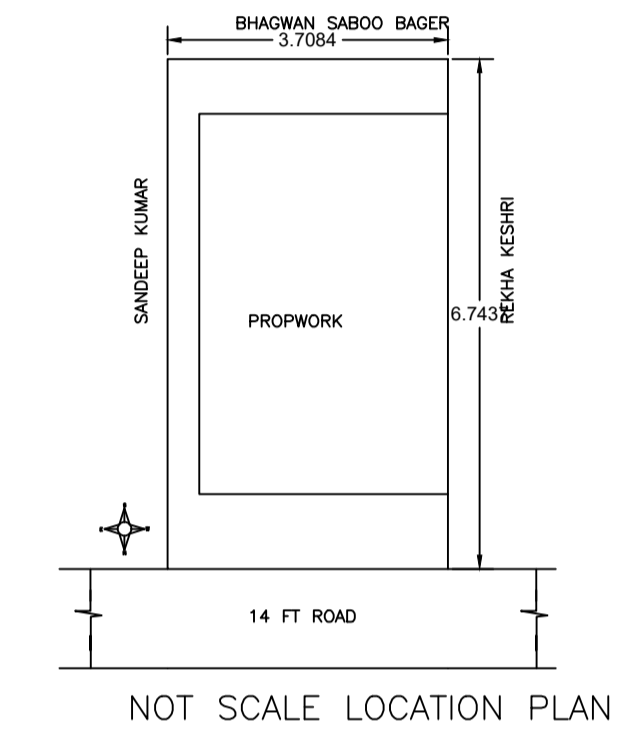

PLAN DET. OF FOUNDATION (SCALE - 1 : 24)

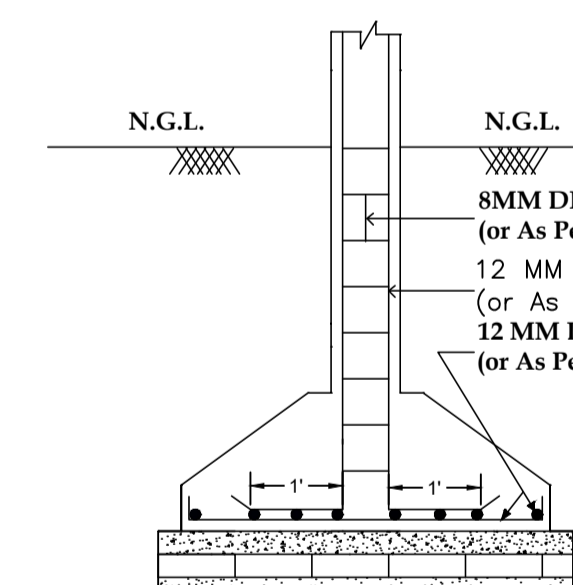

SECTION AT X - X (SCALE - 1 : 24)

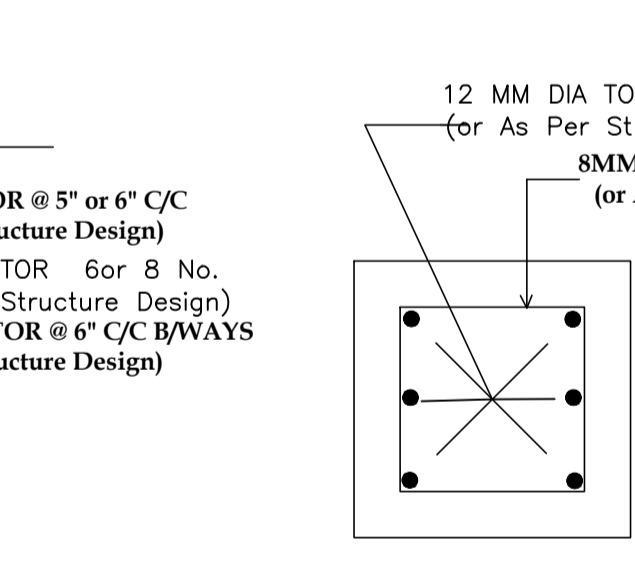

COLUMN SECTION AT Y - Y (NOT TO SCALE)

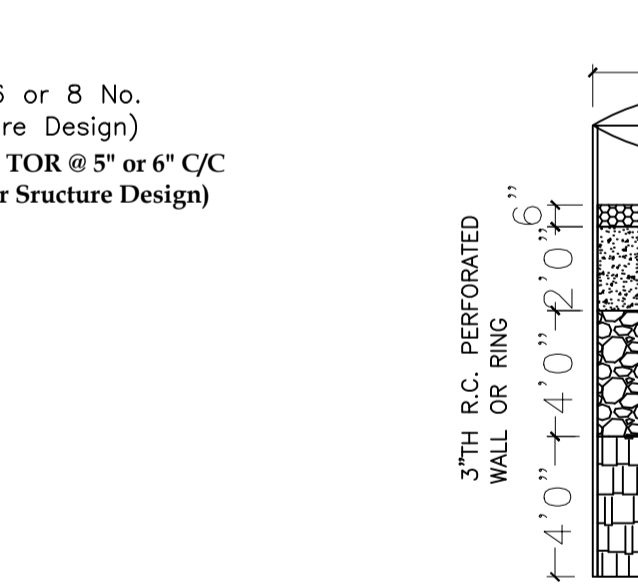

DETAIL OF RAIN WATER (HARVESTING SYSTEM) (SCALE 1"=2'0")

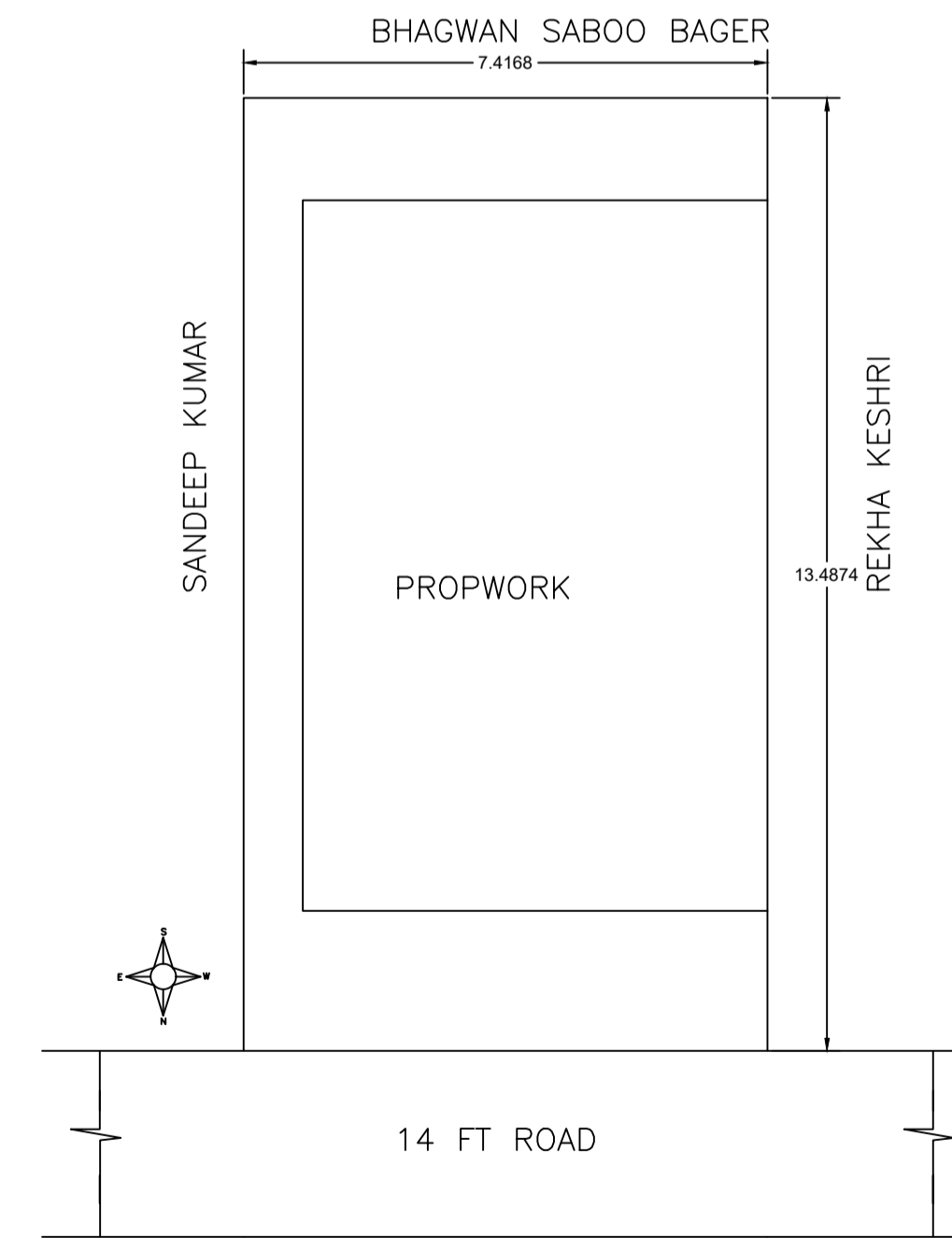

KEY PLAN

FAR & Tenement Details (Table 4c-1)

Building	No. of Same Bldg	Total Built Up Area (Sq.mt.)	Proposed FAR Area (Sq.mt.)	Total FAR Area (Sq.mt.)	Total Consumed Additional FAR Area (Sq.mt.)	Tnmt (No.)
SUDHIR KUMAR (A BUILDING)	1	149.76	149.76	149.76	149.76	01
Grand Total :	1	149.76	149.76	149.76	149.76	01

Buildingwise Floor FAR Details

Floor Name	SUDHIR KUMAR (A BUILDING)		Total	
	Proposed Built Up Area (Sq.mt.)	Proposed FAR Area (Sq.mt.)	Total Proposed Built Up Area (Sq.mt.)	Total FAR Area (Sq.mt.)
Ground Floor	51.34	51.34	51.34	51.34
First Floor	51.50	51.50	51.50	51.50
Second Floor	46.92	46.92	46.92	46.92
Terrace Floor	0.00	0.00	0.00	0.00
Total :	149.76	149.76	149.76	149.76

COLOR INDEX

PLOT BOUNDARY	Black
ABUTTING ROAD	Red
PROPOSED CONSTRUCTION	Green
COMMON PLOT	Blue
ROAD WIDENING AREA	Yellow
EXISTING (To be retained)	Light Blue
EXISTING (To be demolished)	Light Yellow

Building USE/SUBUSE Details

Building Name	Building Use	Building SubUse	Building Structure
SUDHIR KUMAR (A BUILDING)	Residential	Bungalow/ Dwelling / Non Apartment	Non-Highrise

LTP NAME AND SIGNATURE	STRUCTURAL ENG'S NAME AND SIGNATURE	BUILDER NAME AND SIGNATURE	DIGITAL SIGNATURE
RAWNIT KUMAR GUNPC/ENG/0004/2019			
		SUDHIR KUMAR	
			LOCAL BODY