

SECTION A-A  
SCALE 1:100

SECTION B-B  
SCALE 1:100



FRONT ELEVATION  
SCALE 1:100

LEFT SIDE ELEVATION  
SCALE 1:100

Building USE/SUBUSE Details

Building Name	Building Use	Building SubUse	Building Structure	Floor Name	Floor Use	Floor SubUse	FAR Name	FAR Use	FAR SubUse
A (USHA SONI)	Residential	Bungalow/ Dwelling / Non Apartment	Non-Highrise	GROUND FLOOR PLAN	Residential	Bungalow/ Dwelling / Non Apartment	Residential FAR	Residential	Bungalow/ Dwelling / Non Apartment
				TYPICAL - 1& 2 FLOOR PLAN	Residential	Bungalow/ Dwelling / Non Apartment	Residential FAR	Residential	Bungalow/ Dwelling / Non Apartment
				TERRACE FLOOR PLAN	Residential	Bungalow/ Dwelling / Non Apartment	-	-	-

Proposal Basic Information

Proposal File No.	GUNPC/BP/0064/W02/2024
Owner Name	USHA SONI
Khata No	110
Plot No	397
Village Name	Dundurya
Use	Residential
SubUse	Bungalow/ Dwelling / Non Apartment

Color	Description
Red	PLOT BOUNDARY
Green	ABUTTING ROAD
Blue	PROPOSED CONSTRUCTION
Yellow	COMMON PLOT
Orange	ROAD WIDENING AREA
Purple	EXISTING (To be retained)
Light Blue	EXISTING (To be demolished)

Building :A (USHA SONI)

Floor Name	Total Built Up Area (Sq.mt.)	Proposed FAR Area (Sq.mt.)	Total FAR Area (Sq.mt.)	Total Consumed Additional FAR Area (Sq.mt.)	Trmt (No.)
Ground Floor	50.66	50.66	50.66	50.66	01
First Floor	50.66	50.66	50.66	50.66	00
Second Floor	50.66	50.66	50.66	50.66	00
Terrace Floor	0.00	0.00	0.00	0.00	00
Total :	151.98	151.98	151.98	151.98	01
Total Number of Same Buildings	1				
Total :	151.98	151.98	151.98	151.98	01

SCHEDULE OF DOOR:

BUILDING NAME	NAME	LENGTH	HEIGHT	NOS
A (USHA SONI)	D2	0.75	2.10	03
A (USHA SONI)	D	0.90	2.10	03
A (USHA SONI)	D	1.05	2.10	06

SCHEDULE OF WINDOW/VENTILATION:

BUILDING NAME	NAME	LENGTH	HEIGHT	NOS
A (USHA SONI)	W1	0.90	1.20	04
A (USHA SONI)	V	0.90	1.20	03
A (USHA SONI)	W	1.80	1.20	09

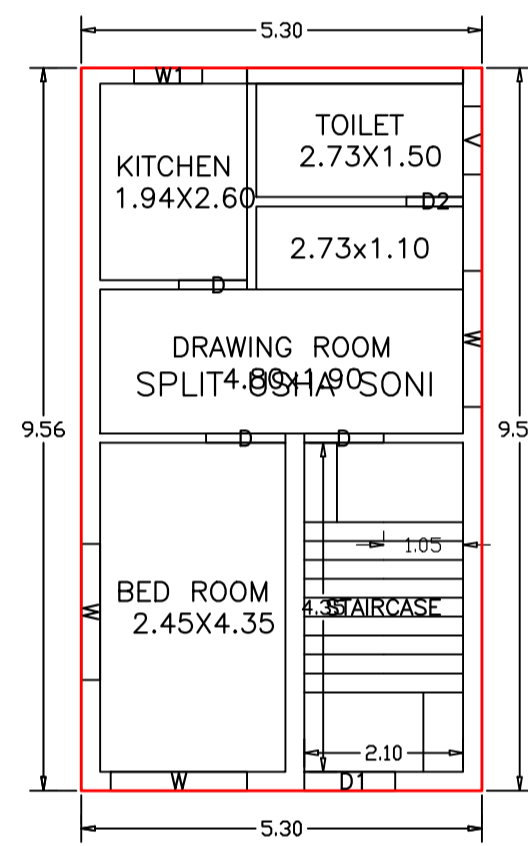

GROUND FLOOR PLAN (Proposed)  
SCALE 1:100

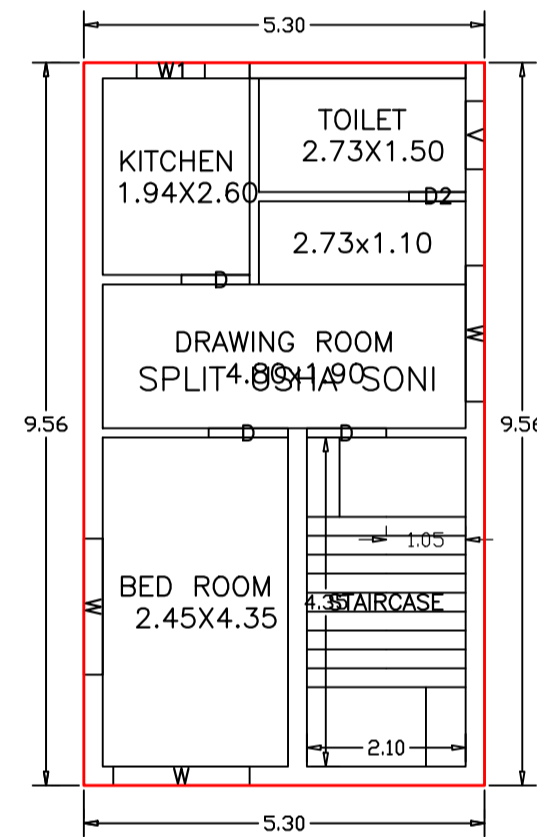

TYPICAL - 1& 2 FLOOR PLAN (Proposed)  
SCALE 1:100

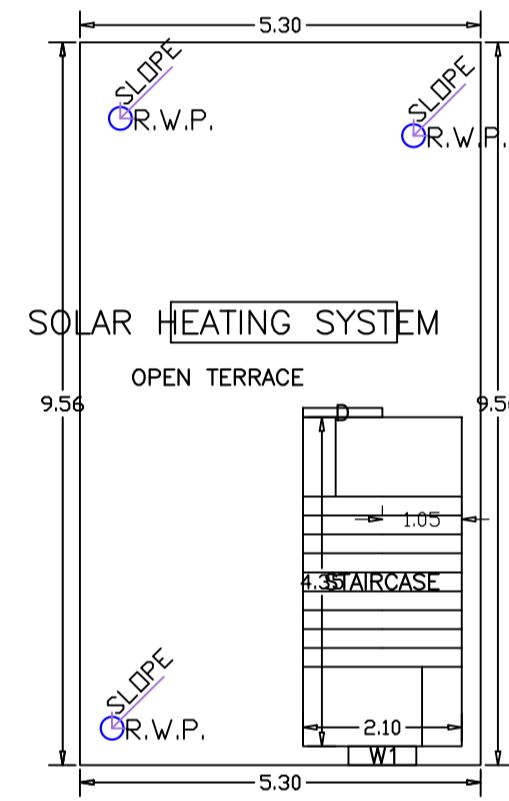

TERRACE FLOOR PLAN (SCALE 1:100)

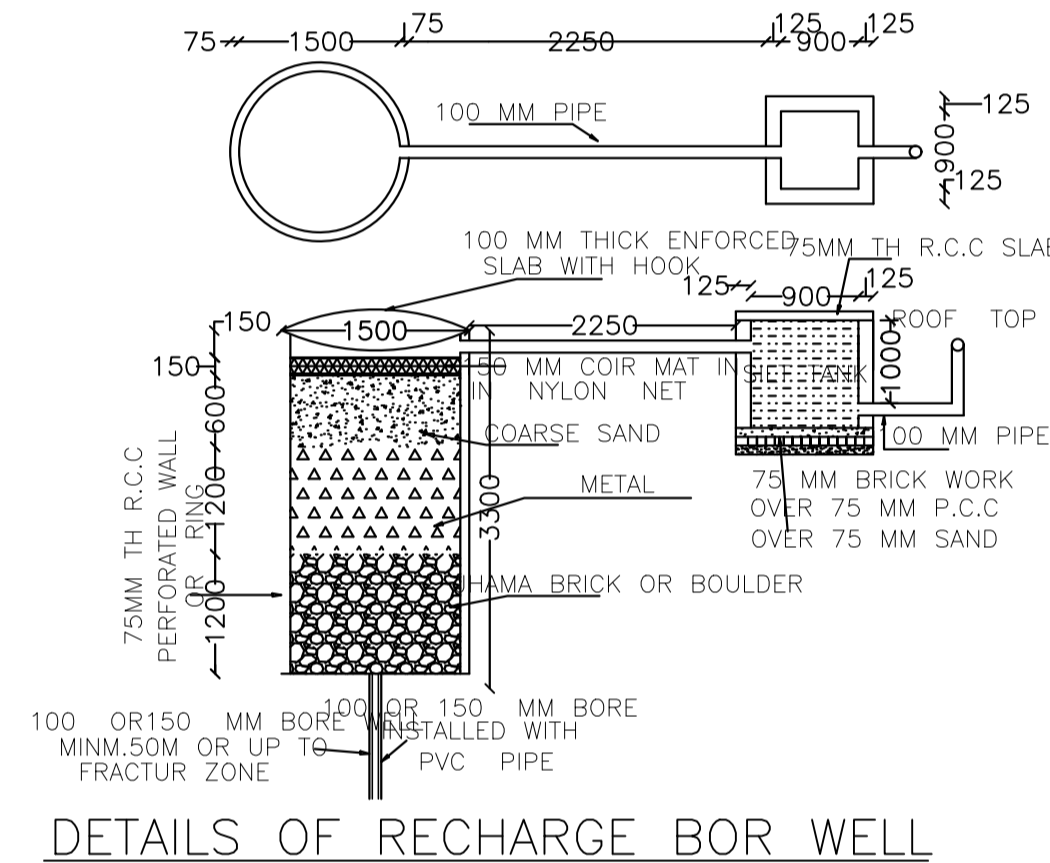

DETAILS OF RECHARGE BOR WELL

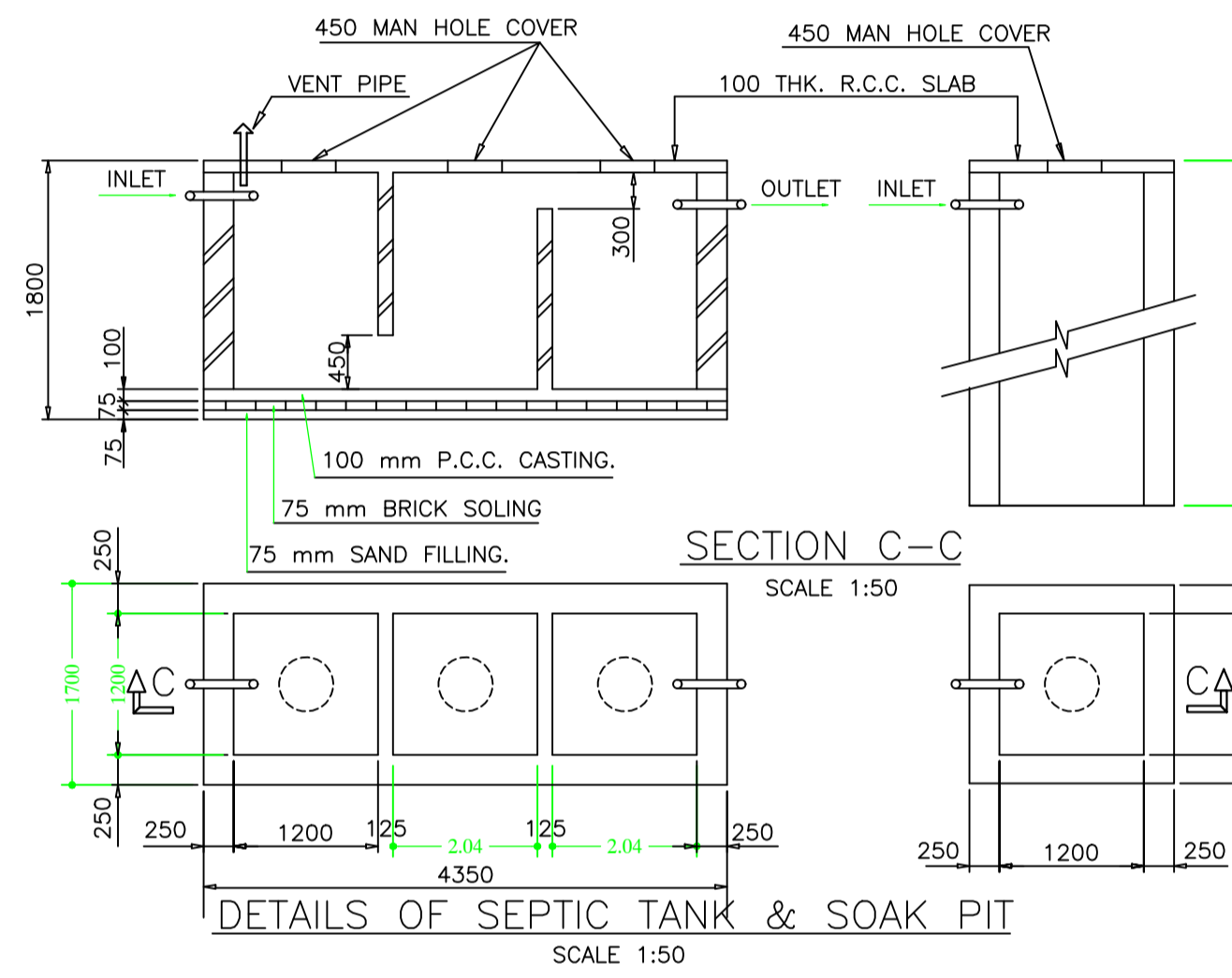

DETAILS OF SEPTIC TANK & SOAK PIT

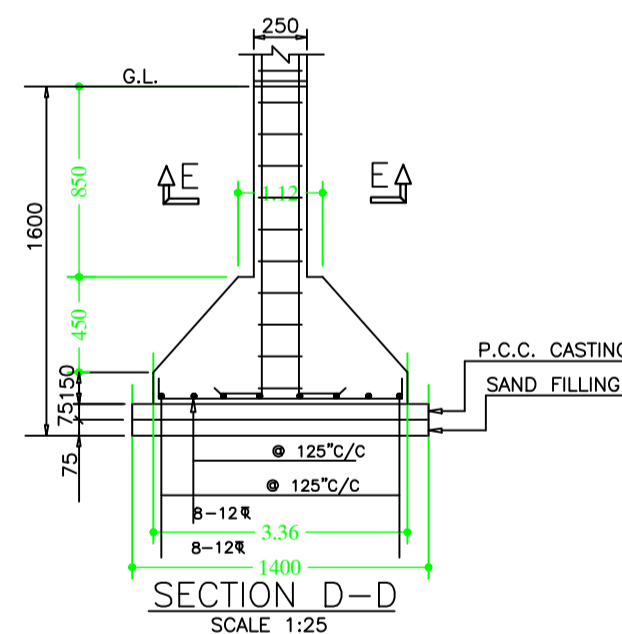

SECTION D-D  
SCALE 1:25

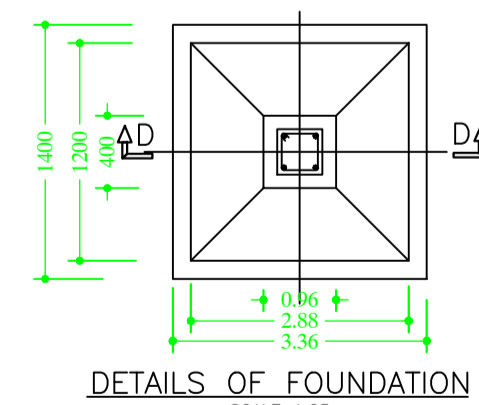

DETAILS OF FOUNDATION  
SCALE 1:25

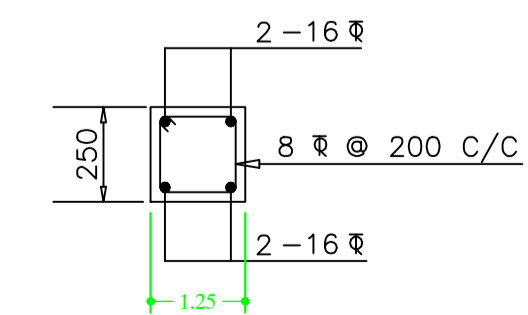

SECTION E-E  
SCALE 1:25

FAR & Tenement Details (Table 4c-1)

Building	No. of Same Bldg	Total Built Up Area (Sq.mt.)	Proposed FAR Area (Sq.mt.)	Total FAR Area (Sq.mt.)	Total Consumed Additional FAR Area (Sq.mt.)	Trmt (No.)
A (USHA SONI)	1	151.98	151.98	151.98	151.98	01
Grand Total :	1	151.98	151.98	151.98	151.98	01

UnitBUA Table for Building :A (USHA SONI)

FLOOR	Name	UnitBUA Type	UnitBUA Area	Carpet Area	No. of Rooms	No. of Tenement
GROUND FLOOR PLAN	SPLIT USHA SONI	FLAT	151.99	150.19	4	1
TYPICAL - 1& 2 FLOOR PLAN	SPLIT USHA SONI	FLAT	0.00	0.00	4	0
Total:	-	-	151.99	150.19	12	1

Buildingwise Floor FAR Details

Floor Name	Building Name		Total	
	Proposed Built Up Area (Sq.mt.)	Proposed FAR Area (Sq.mt.)	Total Proposed Built Up Area (Sq.mt.)	Total FAR Area (Sq.mt.)
Ground Floor	50.66	50.66	50.66	50.66
First Floor	50.66	50.66	50.66	50.66
Second Floor	50.66	50.66	50.66	50.66
Terrace Floor	0.00	0.00	0.00	0.00
Total :	151.98	151.98	151.98	151.98

APPLICANT PLOT

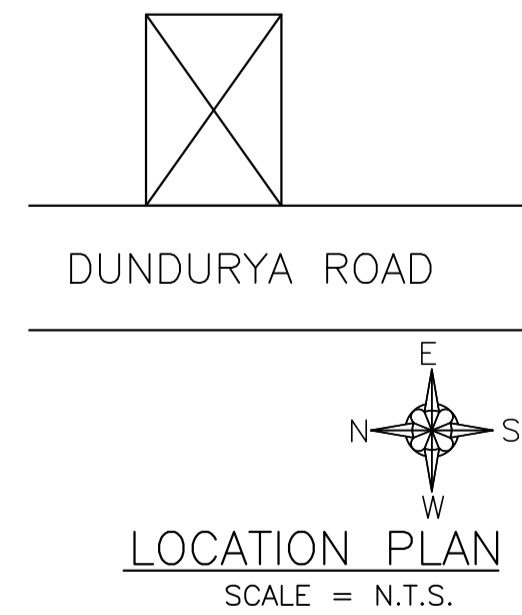

LOCATION PLAN  
SCALE = N.T.S.

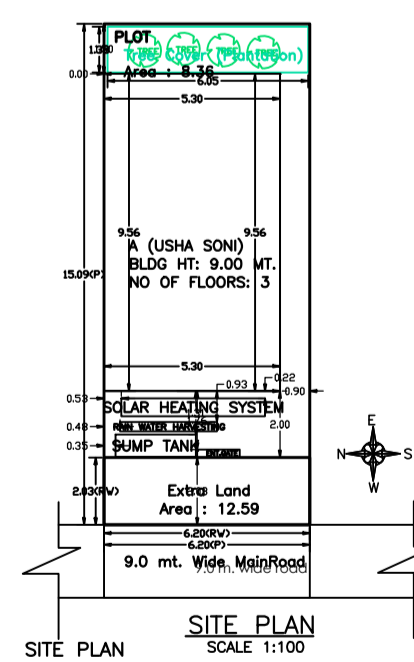

SITE PLAN  
SCALE 1:100

LTP NAME AND SIGNATURE	STRUCTURAL ENG'S NAME AND SIGNATURE	BUILDER NAME AND SIGNATURE	DIGITAL SIGNATURE
DEEPAK DIWAN GUNPC/ARC/0003/2017			