

Proposal Basic Information

Proposal File No.	JNP/BP/0031/W09/2017
Owner Name	SMT RAMDULARI DEVI
Khata No	294
Plot No	7475
Village Name	Tilaiya
Use	Residential
SubUse	Residential Bldg/Apartment

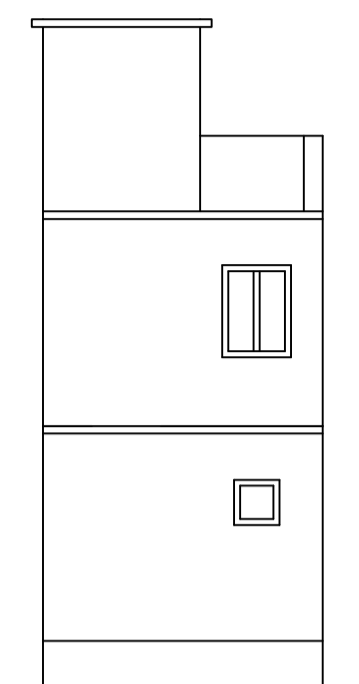

NORTH SIDE ELEVATION
SCALE :- 1"=8'-0"

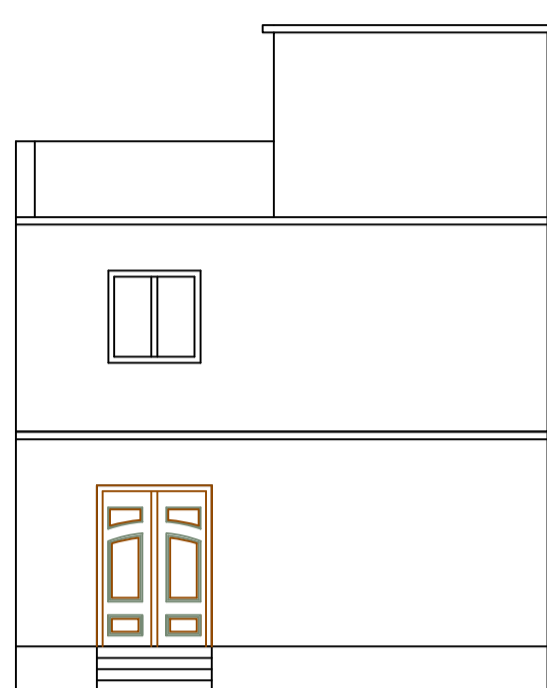

FRONT ELEVATION
SCALE :- 1"=8'-0"

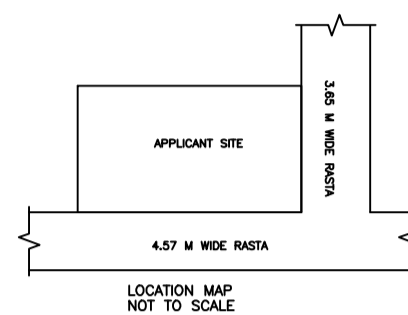

LOCATION MAP
NOT TO SCALE

Building USE/SUBUSE Details

Building Name	Building Use	Building SubUse	Building Structure
A (RAMDULARI DEVI)	Residential	Residential Bldg/Apartment	Non-Highrise

FAR & Tenement Details (Table 4c-1)

Building	No. of Same Bldg	Total Built Up Area (Sq.mt.)	Proposed FAR Area (Sq.mt.)		Total Consumed Additional FAR Area (Sq.mt.)	Tnmt (No.)
			Resi.	Total FAR Area (Sq.mt.)		
A (RAMDULARI DEVI)	1	52.02	52.02	52.02	52.02	01
Grand Total :	1	52.02	52.02	52.02	52.02	01

COLOR INDEX

PLOT BOUNDARY	Black
ABUTTING ROAD	Green
PROPOSED CONSTRUCTION	Red
COMMON PLOT	Yellow
ROAD WIDENING AREA	Blue
EXISTING (To be retained)	Orange
EXISTING (To be demolished)	Purple

SCHEDULE OF DOOR:

BUILDING NAME	NAME	LENGTH	HEIGHT	NOS
A (RAMDULARI DEVI)	D2	0.77	2.13	01
A (RAMDULARI DEVI)	D2	0.60	1.20	01
A (RAMDULARI DEVI)	D1	0.91	2.13	01
A (RAMDULARI DEVI)	D	1.52	2.13	01

SCHEDULE OF WINDOW/VENTILATION:

BUILDING NAME	NAME	LENGTH	HEIGHT	NOS
A (RAMDULARI DEVI)	V	0.60	0.60	02
A (RAMDULARI DEVI)	W2	0.60	1.20	01
A (RAMDULARI DEVI)	W1	0.91	1.22	02
A (RAMDULARI DEVI)	W	1.12	1.22	01
A (RAMDULARI DEVI)	W	1.22	1.22	02

Building -A (RAMDULARI DEVI)

Floor Name	Total Built Up Area (Sq.mt.)	Proposed FAR Area (Sq.mt.) Resi.	Total FAR Area (Sq.mt.)	Total Consumed Additional FAR Area (Sq.mt.)	Tnmt (No.)
Ground Floor	26.01	26.01	26.01	26.01	01
First Floor	26.01	26.01	26.01	26.01	00
Terrace Floor	0.00	0.00	0.00	0.00	00
Total :	52.02	52.02	52.02	52.02	01
Total Number of Same Buildings	1				
Total :	52.02	52.02	52.02	52.02	01

Buildingwise Floor FAR Details

Floor Name	Building Name A (RAMDULARI DEVI)		Total	
	Proposed Built Up Area (Sq.mt.)	Proposed FAR Area (Sq.mt.)	Total Proposed Built Up Area (Sq.mt.)	Total FAR Area (Sq.mt.)
Ground Floor	26.01	26.01	26.01	26.01
First Floor	26.01	26.01	26.01	26.01
Terrace Floor	0.00	0.00	0.00	0.00
Total :	52.02	52.02	52.02	52.02

AREA STATEMENT	VERSION NO.: 1.0.27
JHUMRITILAIYA NAGAR PARISHAD	VERSION DATE: 18/05/2018
PROJECT DETAIL:	
Region: JHARKHAND URBAN LOCAL BODIES	Plot Use: Residential
District: KODERMA	Plot SubUse: Residential Bldg/Apartment
Authority: JHUMRITILAIYA NAGAR PARISHAD	Plot/Nearby/Religious Structure: NA
Inward No: JNP/BP/0031/W09/2017	Plot/SubPlot No: 7475
Application Type: General Proposal	North: -
Project Type: Building Permission	South: -
Nature of Development: New	East: -
Location of Development Area: Old Area	West: -

AREA DETAILS:		SQ. MT.
AREA OF PLOT (Minimum)	(A)	48.38
NET AREA OF PLOT(Gross Plot Area - Deduction from Gross Plot area)	(A-Deductions)	48.38
Deduction for Balance Plot Area(from Gross Plot Area)		
Common Plot		5.62
Total		5.62
BALANCE AREA OF PLOT(Net Plot Area - Recreational/Amenity space)	(A-Deductions)	42.75
PLOT AREA FOR COVERAGE(Net Plot Area)	(A-Deductions)	48.38
Plot Area for FAR (Net Plot Area + Road/Widening Area)	(A-Deductions)	48.38
COVERAGE CHECK		
Permissible Coverage area (70.00 %)		33.86
Proposed Coverage Area (53.77 %)		26.01
Total Prop. Coverage Area (53.77 %)		26.01
Balance coverage area (16.23 %)		7.85
FAR CHECK		
Perm. FAR Area (1.50)		72.56
Total Perm. FAR area		72.56
Residential FAR		52.02
Proposed FAR Area		52.02
Total Proposed FAR Area		52.02
Consumed FAR (Factor)		1.08
Balance FAR Area		20.54
BUILT UP AREA CHECK		
Total Proposed BuiltUp Area		52.02
ARCHITECT (Regd)		MD SHOAB ALAM
ENGINEER (Regd)		
SUPERVISOR (Regd)		
OWNER (Regd)		SMT RAMDULARI DEVI
DEVELOPMENT AUTHORITY		LOCAL BODY

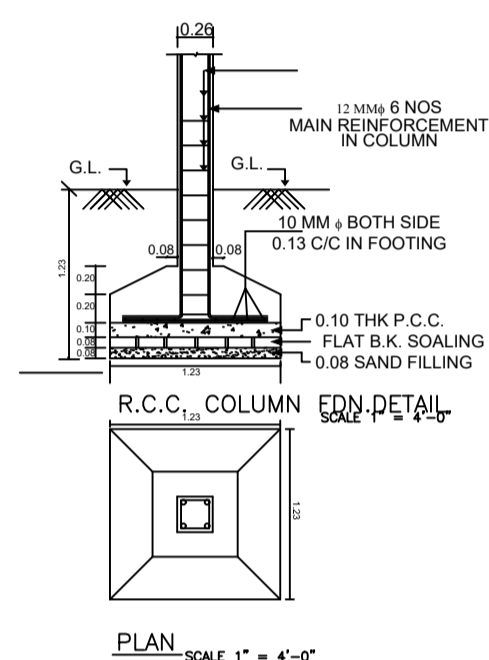
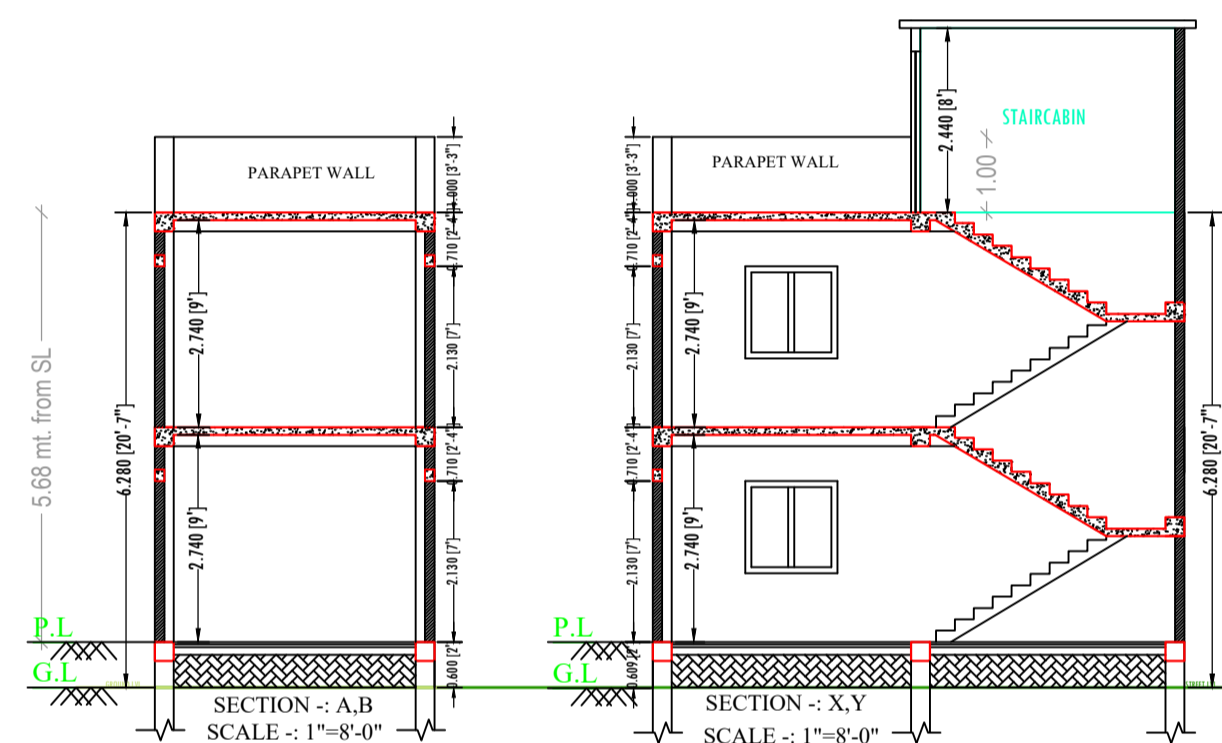

UnitBUA Table for Building -A (RAMDULARI DEVI)

FLOOR	Name	UnitBUA Type	UnitBUA Area	Carpet Area	No. of Rooms	No. of Tenement
GROUND FLOOR PLAN	SPLIT FLAT A	FLAT	34.00	32.99	2	1
FIRST FLOOR PLAN	SPLIT FLAT A	FLAT	0.00	0.00	3	0
Total:	-	-	34.00	32.99	5	1

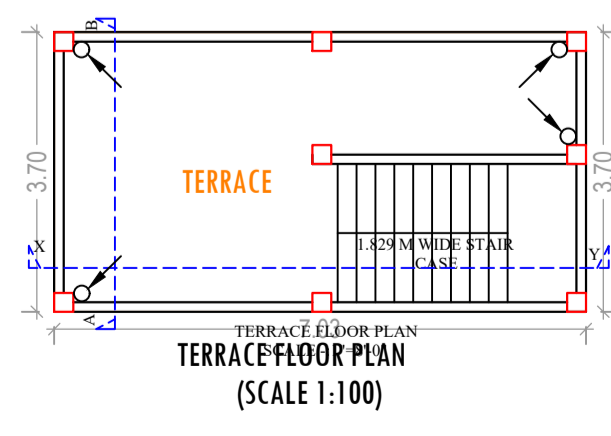
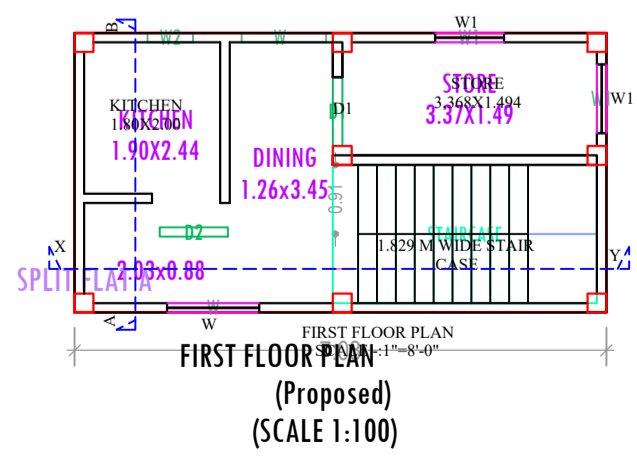
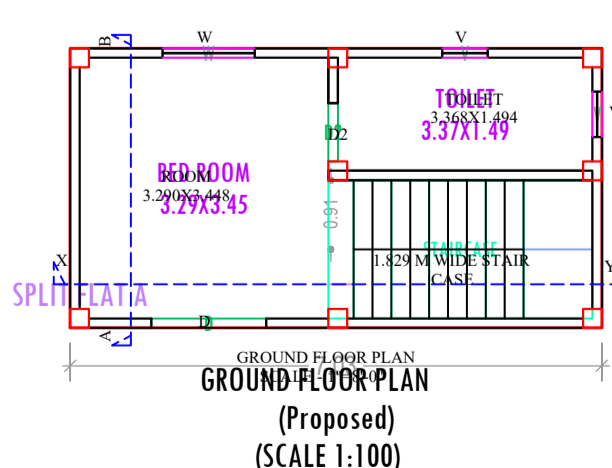
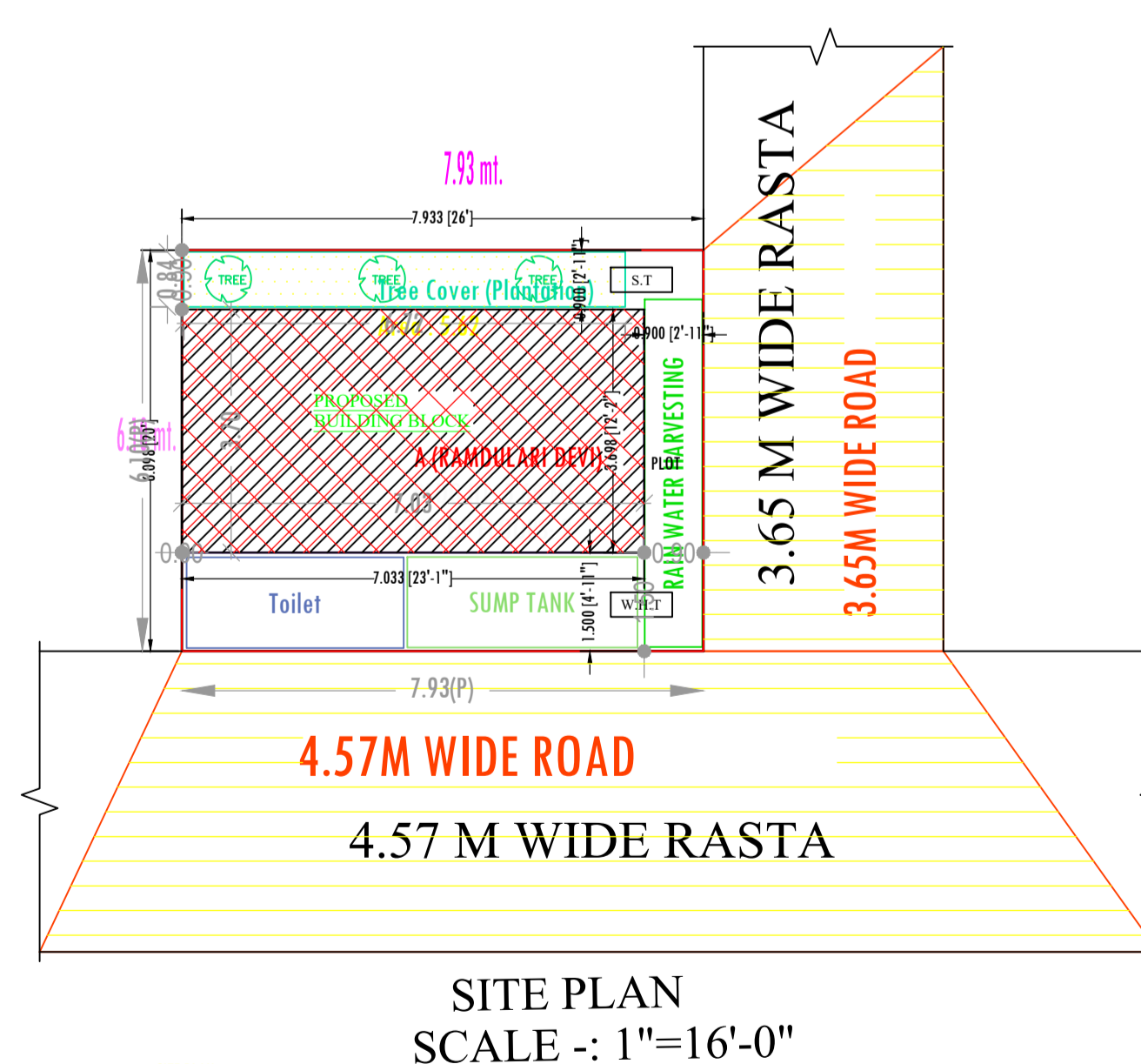
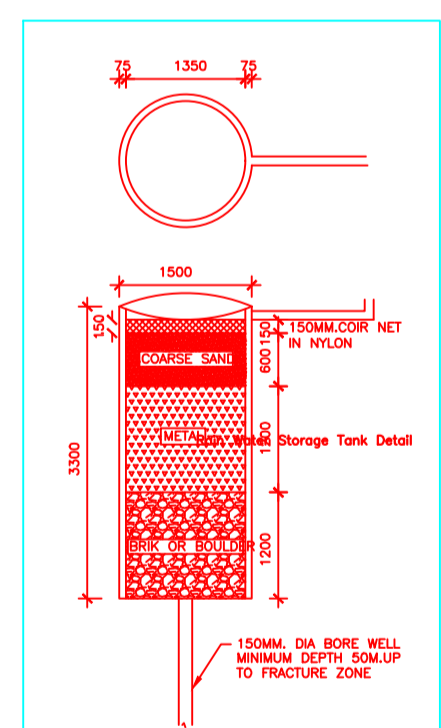
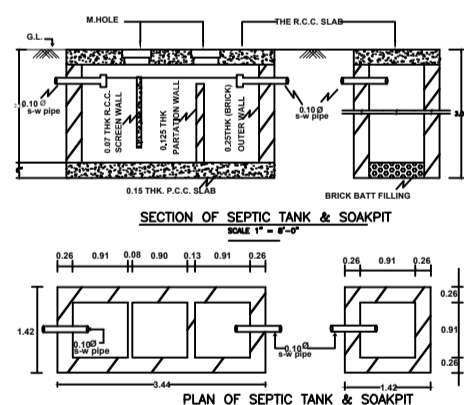

LTP NAME AND SIGNATURE	STRUCTURAL ENG'S NAME AND SIGNATURE	BUILDER NAME AND SIGNATURE
MD SHOAB ALAM JNP/ENG/0001/2017		