

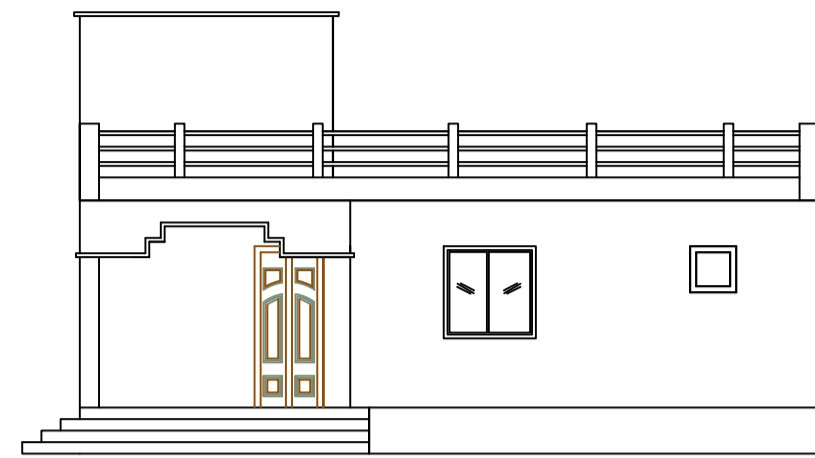

COLOR INDEX	
PLOT BOUNDARY	[Red Line]
ABUTTING ROAD	[Green Line]
PROPOSED CONSTRUCTION	[Yellow Area]
COMMON PLOT	[Red Area]
ROAD WIDENING AREA	[Blue Area]
EXISTING (To be retained)	[Green Area]
EXISTING (To be demolished)	[Red Area]

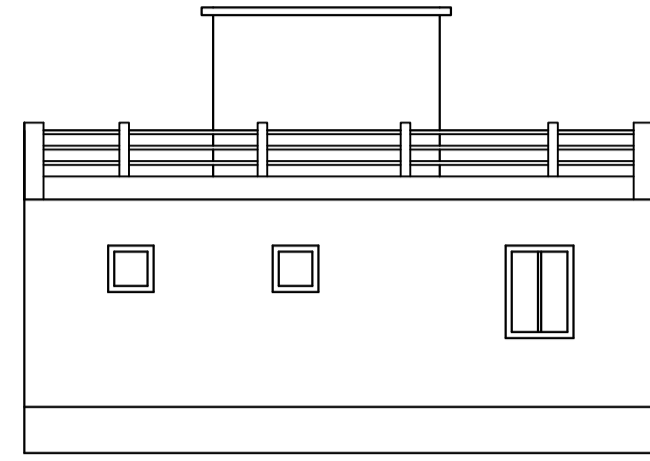

FRONT ELEVATION
SCALE 1" = 8'-0"



SIDE ELEVATION
SCALE 1" = 8'-0"

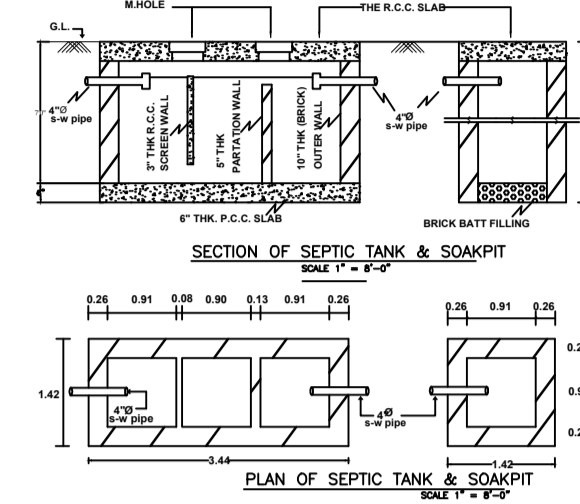
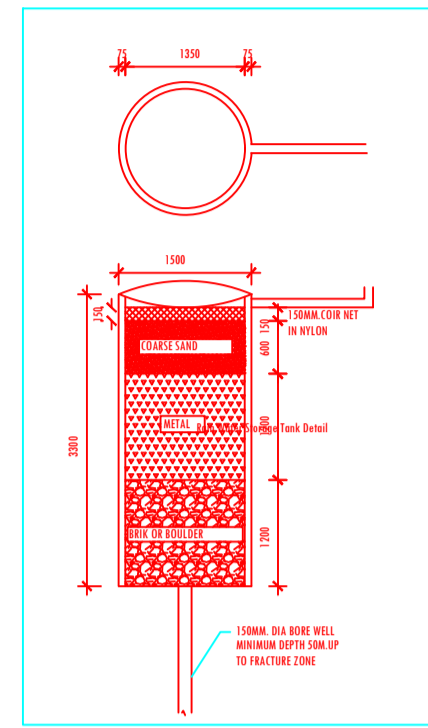

FAR & Tenement Details (Table 4c-1)

Building	No. of Same Bldg	Total Built Up Area (Sq.mt.)	Proposed FAR Area (Sq.mt.) Resi.	Total FAR Area (Sq.mt.)	Total Consumed Additional FAR Area (Sq.mt.)	Tnmt (No.)
AAAAAA (RAJKISHOR PDD)	1	74.75	74.75	74.75	74.75	01
Grand Total:	1	74.75	74.75	74.75	74.75	01

UnitBUA Table for Building :AAAAAA (RAJKISHOR PDD)

FLOOR	Name	UnitBUA Type	UnitBUA Area	Carpet Area	No. of Rooms	No. of Tenement
GROUND FLOOR PLAN	SPLIT FLAT 1	FLAT	67.77	65.63	6	1
Total:	-	-	67.77	65.63	6	1

Building USE/SUBUSE Details

Building Name	Building Use	Building SubUse	Building Structure
AAAAAA (RAJKISHOR PDD)	Residential	Residential Bldg/Apartment	Non-Highrise

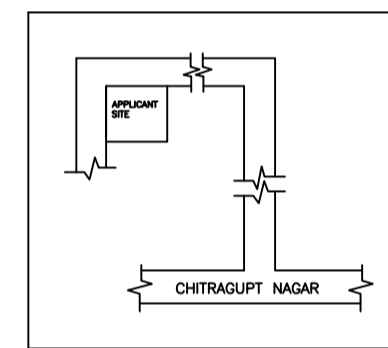

LOCATION MAP
NOT TO SCALE

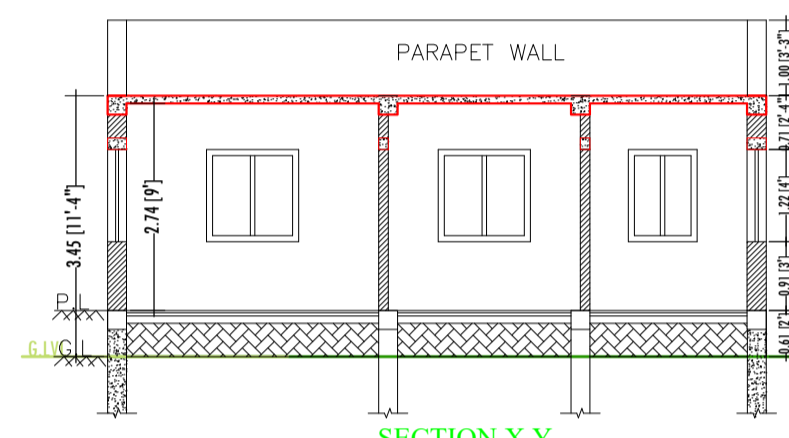

SECTION X.Y
SCALE 1" = 8'-0"

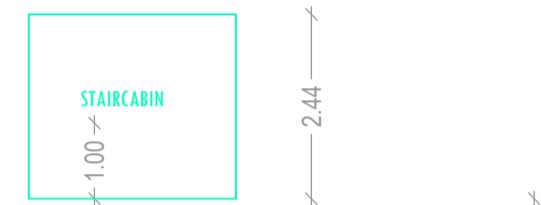

STAIRCABIN

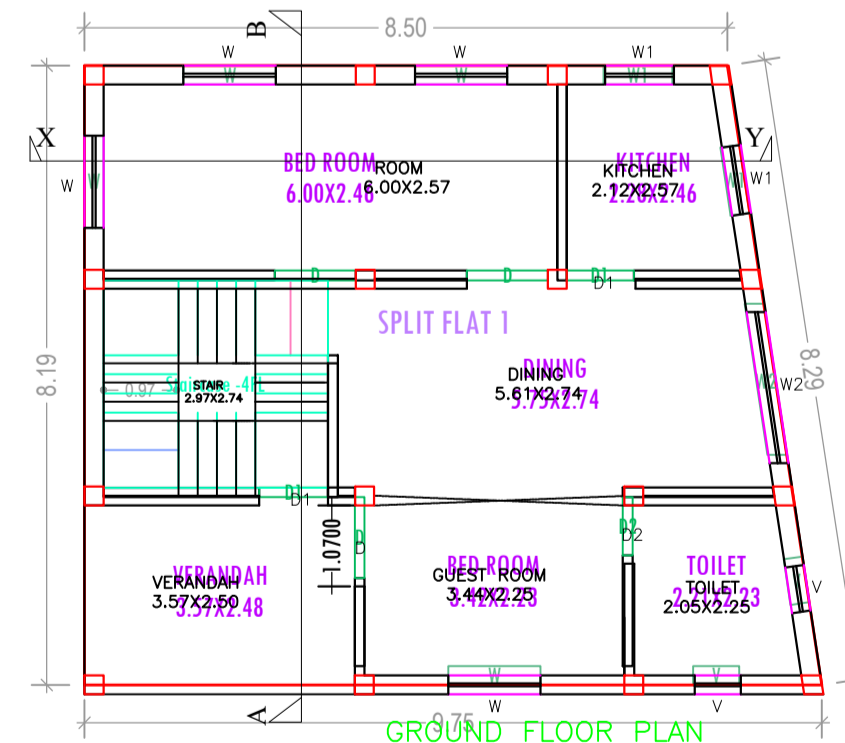

GROUND FLOOR PLAN (Proposed)
SCALE 1" = 100'

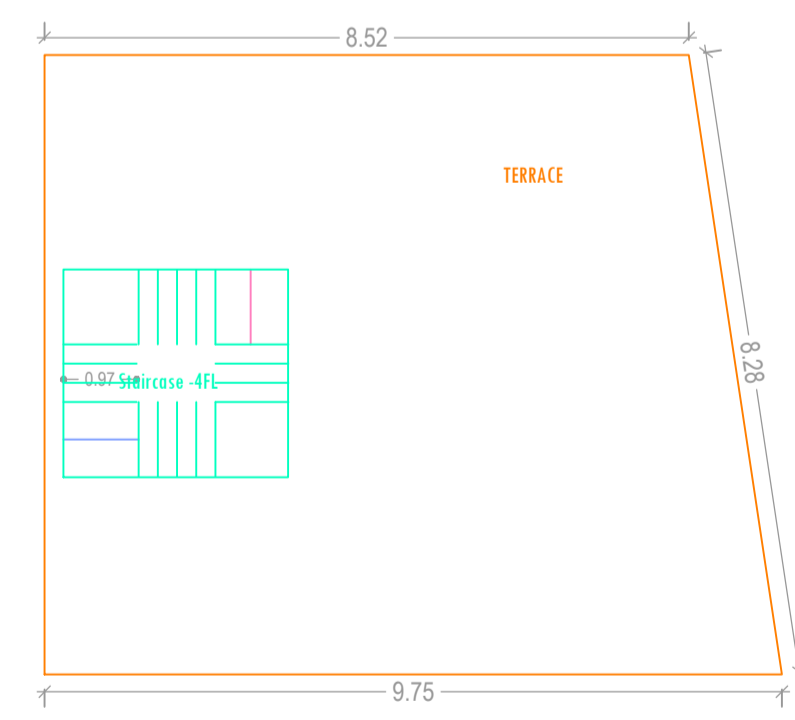

TERRACE FLOOR PLAN
SCALE 1" = 100'

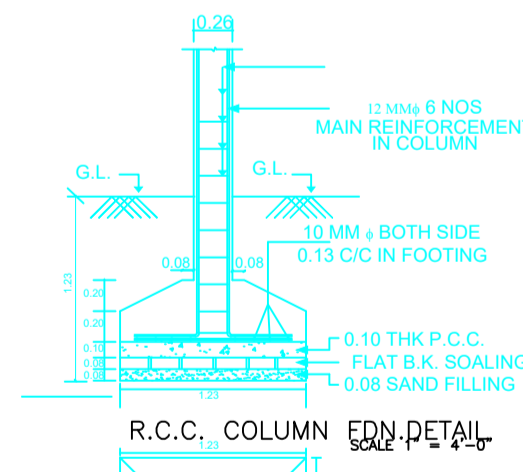

R.C.C. COLUMN & FOOTING DETAIL
SCALE 1" = 4'-0"

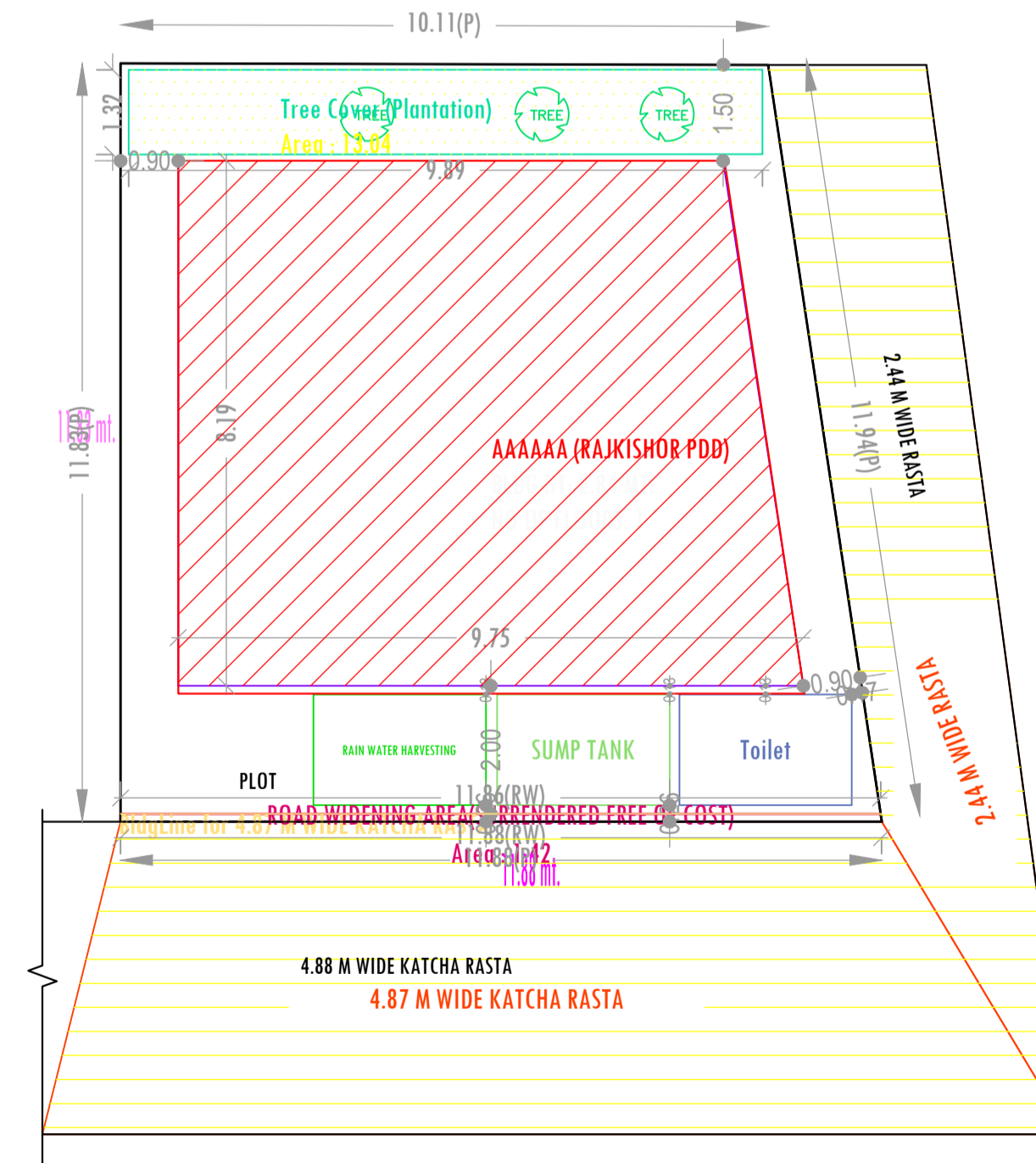

SITE PLAN

Buildingwise Floor FAR Details

Floor Name	Building Name		Total	
	Proposed Built Up Area (Sq.mt.)	Proposed FAR Area (Sq.mt.)	Total Proposed Built Up Area (Sq.mt.)	Total FAR Area (Sq.mt.)
Ground Floor	74.75	74.75	74.75	74.75
Terrace Floor	0.00	0.00	0.00	0.00
Total:	74.75	74.75	74.75	74.75

Building :AAAAAA (RAJKISHOR PDD)

Floor Name	Total Built Up Area (Sq.mt.)	Proposed FAR Area (Sq.mt.) Resi.	Total FAR Area (Sq.mt.)	Total Consumed Additional FAR Area (Sq.mt.)	Tnmt (No.)
Ground Floor	74.75	74.75	74.75	74.75	01
Terrace Floor	0.00	0.00	0.00	0.00	00
Total:	74.75	74.75	74.75	74.75	01

SCHEDULE OF DOOR:

BUILDING NAME	NAME	LENGTH	HEIGHT	NOS
AAAAAA (RAJKISHOR PDD)	D2	0.77	2.13	01
AAAAAA (RAJKISHOR PDD)	D1	0.89	2.13	01
AAAAAA (RAJKISHOR PDD)	D1	0.91	2.13	01
AAAAAA (RAJKISHOR PDD)	D	1.07	2.13	03

SCHEDULE OF WINDOW/VENTILATION:

BUILDING NAME	NAME	LENGTH	HEIGHT	NOS
AAAAAA (RAJKISHOR PDD)	V	0.61	0.61	02
AAAAAA (RAJKISHOR PDD)	W1	0.91	1.22	02
AAAAAA (RAJKISHOR PDD)	W	1.22	1.22	04
AAAAAA (RAJKISHOR PDD)	W2	2.02	1.22	01

AREA STATEMENT	VERSION NO.: 1.0.22
JHUMRITILAIYA NAGAR PARISHAD	VERSION DATE: 28/09/2017

PROJECT DETAIL:	Plot Use: Residential
Region: JHARKHAND URBAN LOCAL BODIES	Plot SubUse: Boarding
District: KODERMA	PlotNearbyReligiousStructure: NA
Authority: JHUMRITILAIYA NAGAR PARISHAD	PlotSubPlot No: 1181
Inward No: JNP/BP/0003/W22/2017	North: Plot No. - PART OF PLOT NO 1181
Application Type: General Proposal	South: Road Width - 2.43M WIDE KATCHA ROAD (SRI JITENDERA KUMAR)
Project Type: Building Permission	East: Plot No. - TODAY SOLD SRI JITENDERA KUMAR
Nature of Development: New	West: Road Width - 4.87 M WIDE KATCHA ROAD

AREA STATEMENT	AREA	SQ. MT.
AREA OF PLOT (Minimum)	(A)	129.91
Deduction for NetPlot Area		
Surrender Free of Cost		1.42
Total		1.42
NET AREA OF PLOT(Gross Plot Area - Deduction from Gross Plot area)	(A-Deductions)	128.49
Deduction for Balance Plot Area(from Gross Plot Area)		
Surrender Free of Cost		1.42
Common Plot		13.04
Total		14.46
BALANCE AREA OF PLOT(Net Plot Area - Recreational/Amenity space)	(A-Deductions)	115.45
PLOT AREA FOR COVERAGE(Net Plot Area)	(A-Deductions)	128.49
Plot Area for FAR (Net Plot Area + Road/Widening Area)	(A-Deductions)	129.91

COVERAGE CHECK	PERCENTAGE
Permissible Coverage area (70.00 %)	89.94
Proposed Coverage Area (58.18 %)	74.75
Total Prop. Coverage Area (58.18 %)	74.75
Balance coverage area (11.82 %)	15.19

FAR CHECK	PERCENTAGE
Perm. FAR Area (1.80)	233.84
Total Perm. FAR area	233.84
Residential FAR	74.75
Proposed FAR Area	74.75
Total Proposed FAR Area	74.75
Consumed FAR (Factor)	0.58
Balance FAR Area	159.09

BUILT UP AREA CHECK	PERCENTAGE
Total Proposed BuiltUp Area	74.75

ARCHITECT (Regd)	MD SHOAB ALAM
ENGINEER (Regd)	
SUPERVISOR (Regd)	
OWNER (Regd)	SRI RAJKISHOR PRASAD
DEVELOPMENT AUTHORITY	LOCAL BODY

LTP NAME AND SIGNATURE	STRUCTURAL ENG'S NAME AND SIGNATURE	BUILDER NAME AND SIGNATURE
MD SHOAB ALAM JNP/ENG/0001/2017		