

FRONT ELEVATION
SCALE :- 1"=8'-0"

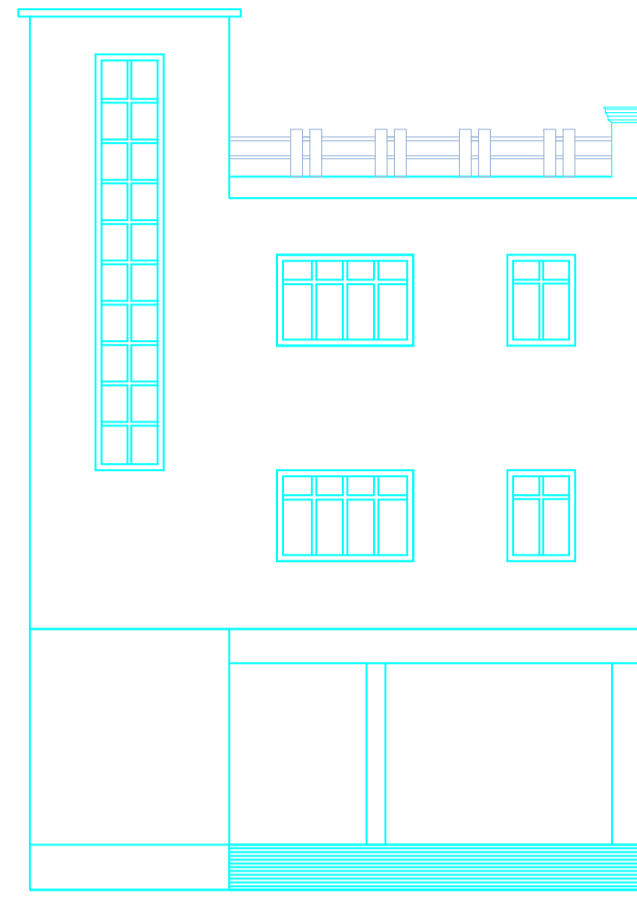

SIDE ELEVATION
SCALE :- 1"=8'-0"

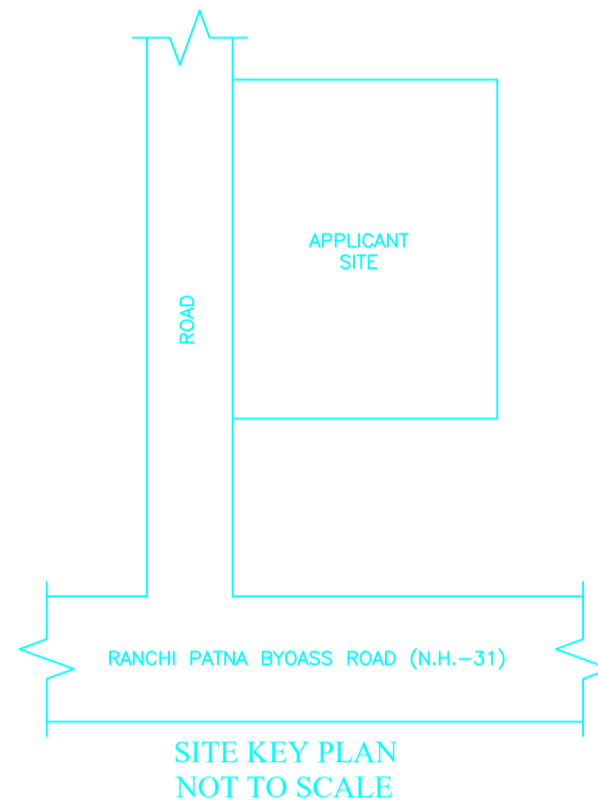

SITE KEY PLAN
NOT TO SCALE

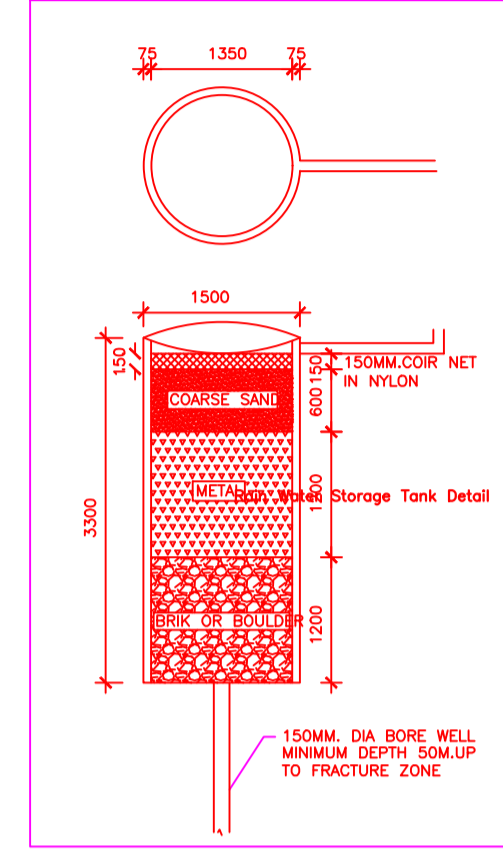

COLOR INDEX	
PLOT BOUNDARY	Black
ABUTTING ROAD	Red
PROPOSED CONSTRUCTION	Green
COMMON PLOT	Yellow
ROAD WIDENING AREA	Blue
EXISTING (To be retained)	Orange
EXISTING (To be demolished)	Light Blue

FAR & Tenement Details (Table 4c-1)

Building	No. of Same Bldg	Total Built Up Area (Sq.mt.)	Deductions (Area in Sq.mt.)	Proposed FAR Area (Sq.mt.)	Add Area In FAR (Sq.mt.)	Total FAR Area (Sq.mt.)	Total Consumed Additional FAR Area (Sq.mt.)	Tnmt (No.)
A (PALLAVI)	1	148.05	40.25	98.70	9.10	107.80	107.80	01
Grand Total:	1	148.05	40.25	98.70	9.10	107.80	107.80	01

Building Use/SUBUSE Details

Building Name	Building Use	Building SubUse	Building Structure
A (PALLAVI)	Residential	Residential Bldg/Apartment	Non-Highrise

Buildingwise Floor FAR Details

Floor Name	Building Name A (PALLAVI)		Total	
	Proposed Built Up Area (Sq.mt.)	Proposed FAR Area (Sq.mt.)	Total Proposed Built Up Area (Sq.mt.)	Total FAR Area (Sq.mt.)
Ground Floor	49.35	9.10	49.35	9.10
First Floor	49.35	49.35	49.35	49.35
Second Floor	49.35	49.35	49.35	49.35
Terrace Floor	0.00	0.00	0.00	0.00
Total :	148.05	107.80	148.05	107.80

Building -A (PALLAVI)

Floor Name	Total Built Up Area (Sq.mt.)	Deductions (Area in Sq.mt.)	Proposed FAR Area (Sq.mt.)	Add Area In FAR (Sq.mt.)	Total FAR Area (Sq.mt.)	Total Consumed Additional FAR Area (Sq.mt.)	Tnmt (No.)
Ground Floor	49.35	40.25	0.00	9.10	9.10	9.10	00
First Floor	49.35	0.00	49.35	0.00	49.35	49.35	01
Second Floor	49.35	0.00	49.35	0.00	49.35	49.35	00
Terrace Floor	0.00	0.00	0.00	0.00	0.00	0.00	00
Total :	148.05	40.25	98.70	9.10	107.80	107.80	01
Total Number of Same Buildings :	1						
Total :	148.05	40.25	98.70	9.10	107.80	107.80	01

UnitBUA Table for Building -A (PALLAVI)

FLOOR	Name	UnitBUA Type	UnitBUA Area	Carpet Area	No. of Rooms	No. of Tenement
FIRST FLOOR PLAN	SPLIT FLAT A	FLAT	65.75	62.82	4	1
SECOND FLOOR PLAN	SPLIT FLAT A	FLAT	0.00	0.00	4	0
Total:	-	-	65.75	62.82	8	1

SCHEDULE OF DOOR:

BUILDING NAME	NAME	LENGTH	HEIGHT	NOS
A (PALLAVI)	D2	0.75	2.13	02
A (PALLAVI)	D1	0.90	2.13	01
A (PALLAVI)	D	1.00	2.10	01
A (PALLAVI)	D	1.00	2.13	02

SCHEDULE OF WINDOW/VENTILATION:

BUILDING NAME	NAME	LENGTH	HEIGHT	NOS
A (PALLAVI)	V	0.60	0.60	02
A (PALLAVI)	W2	0.90	1.20	04
A (PALLAVI)	W1	1.21	1.20	02
A (PALLAVI)	W	1.80	1.20	02

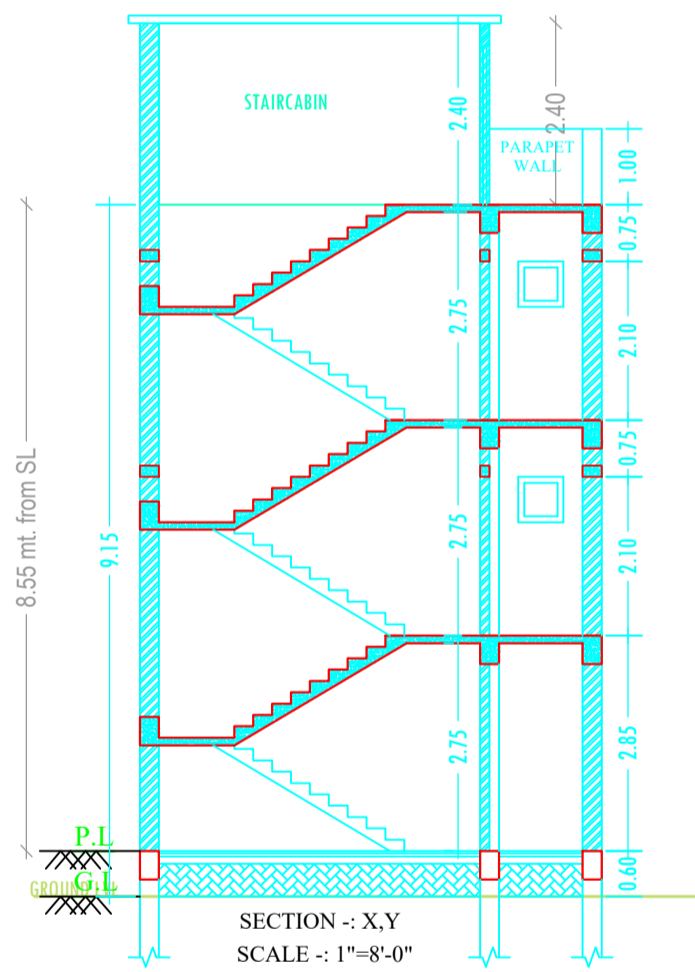

SECTION - X,Y
SCALE :- 1"=8'-0"

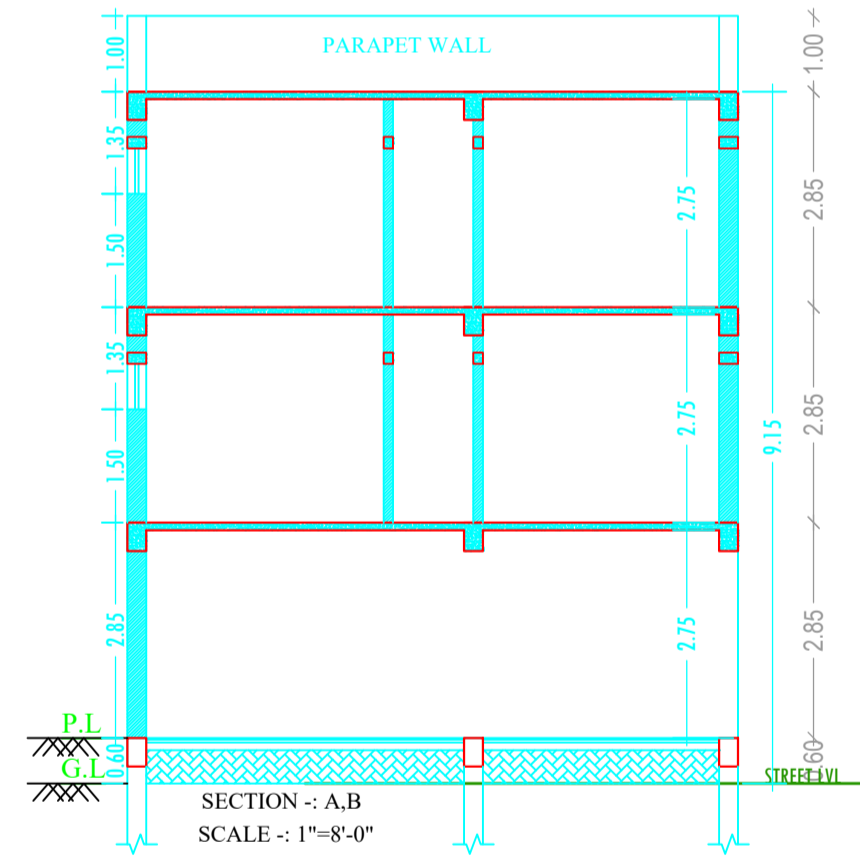

SECTION - A,B
SCALE :- 1"=8'-0"

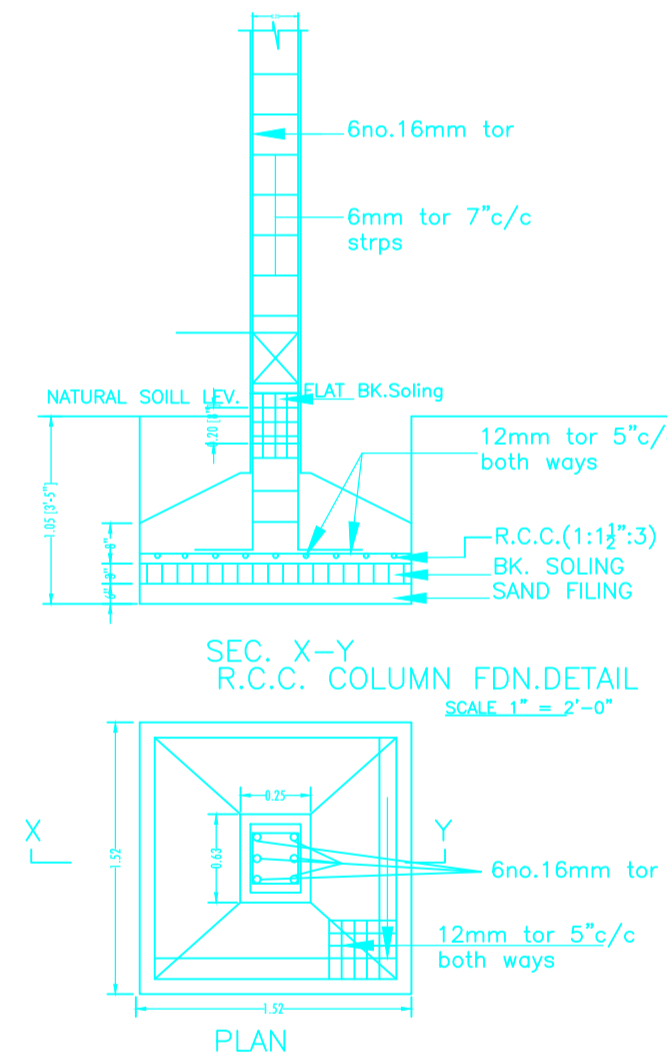

SCALE-1"=2'-0"

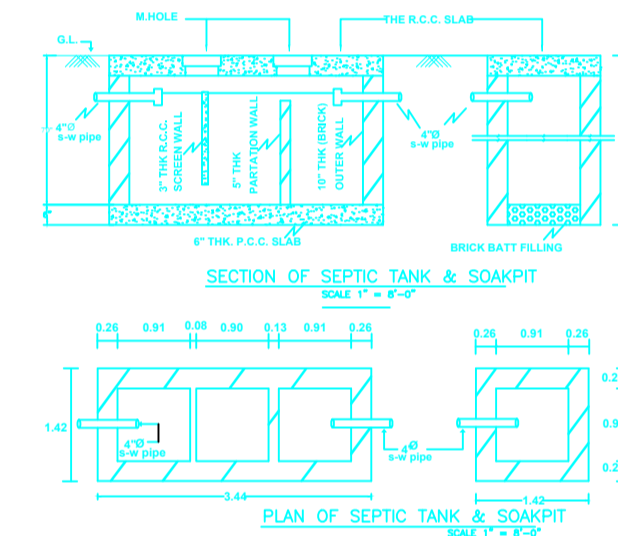

PLAN OF SEPTIC TANK & SOAKPIT

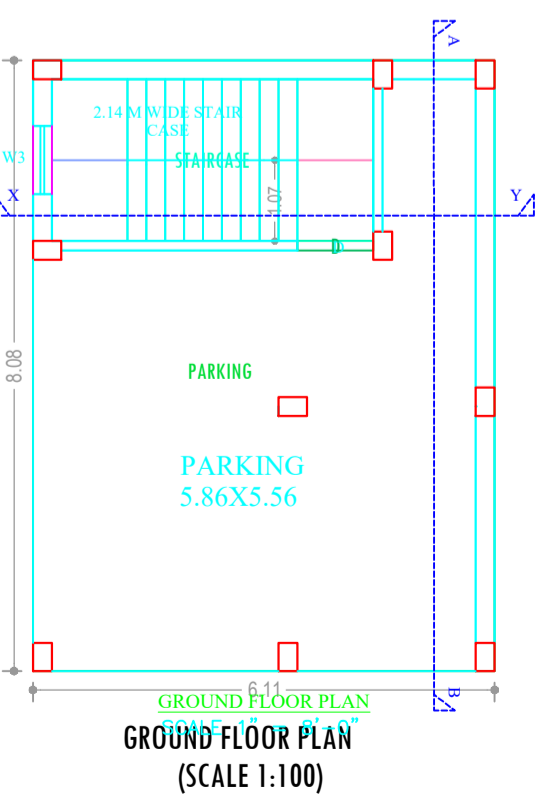

GROUND FLOOR PLAN
(SCALE 1:100)

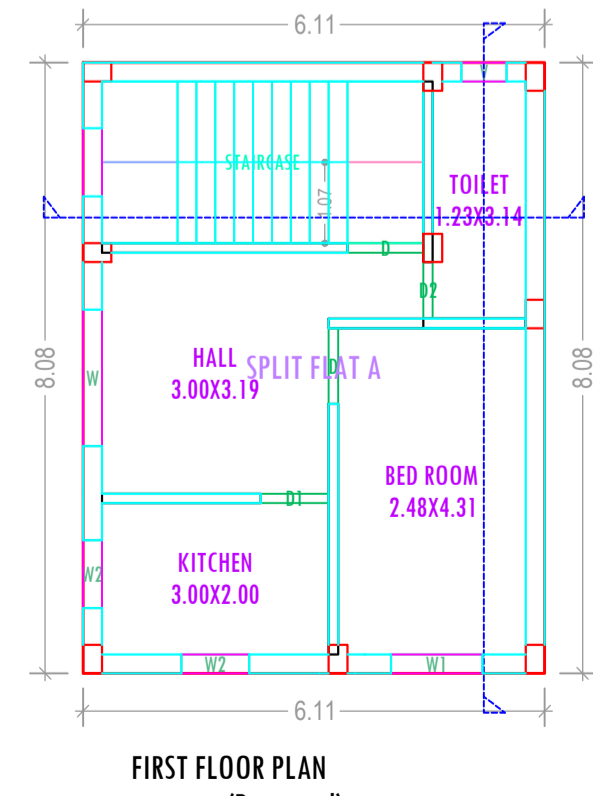

FIRST FLOOR PLAN
(Proposed)
(SCALE 1:100)

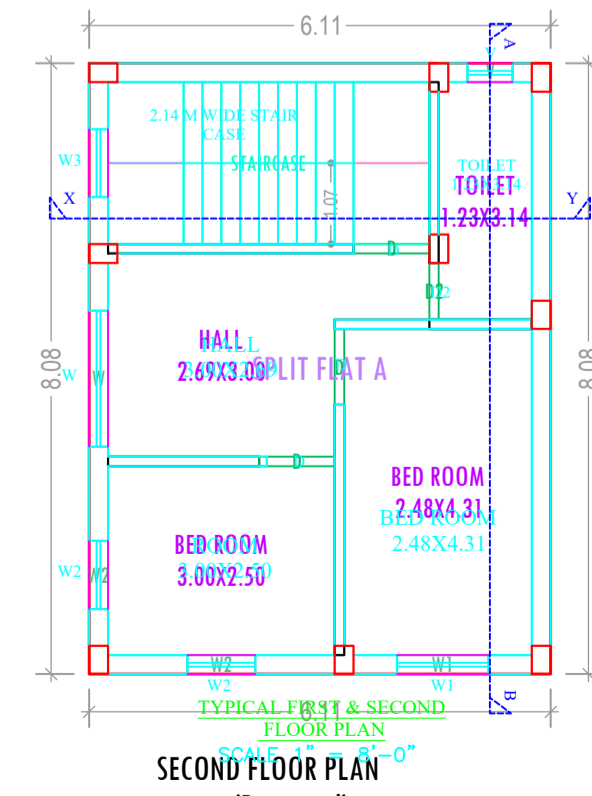

SECOND FLOOR PLAN
(Proposed)
(SCALE 1:100)

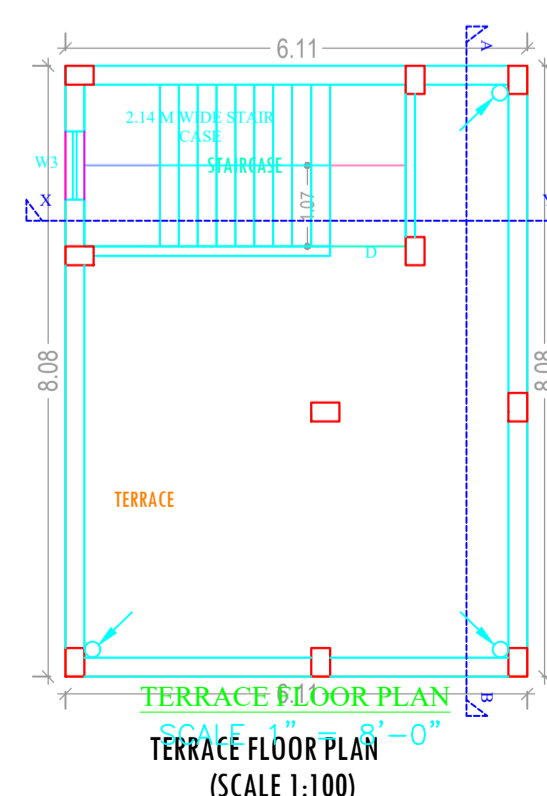

TERRACE FLOOR PLAN
(SCALE 1:100)

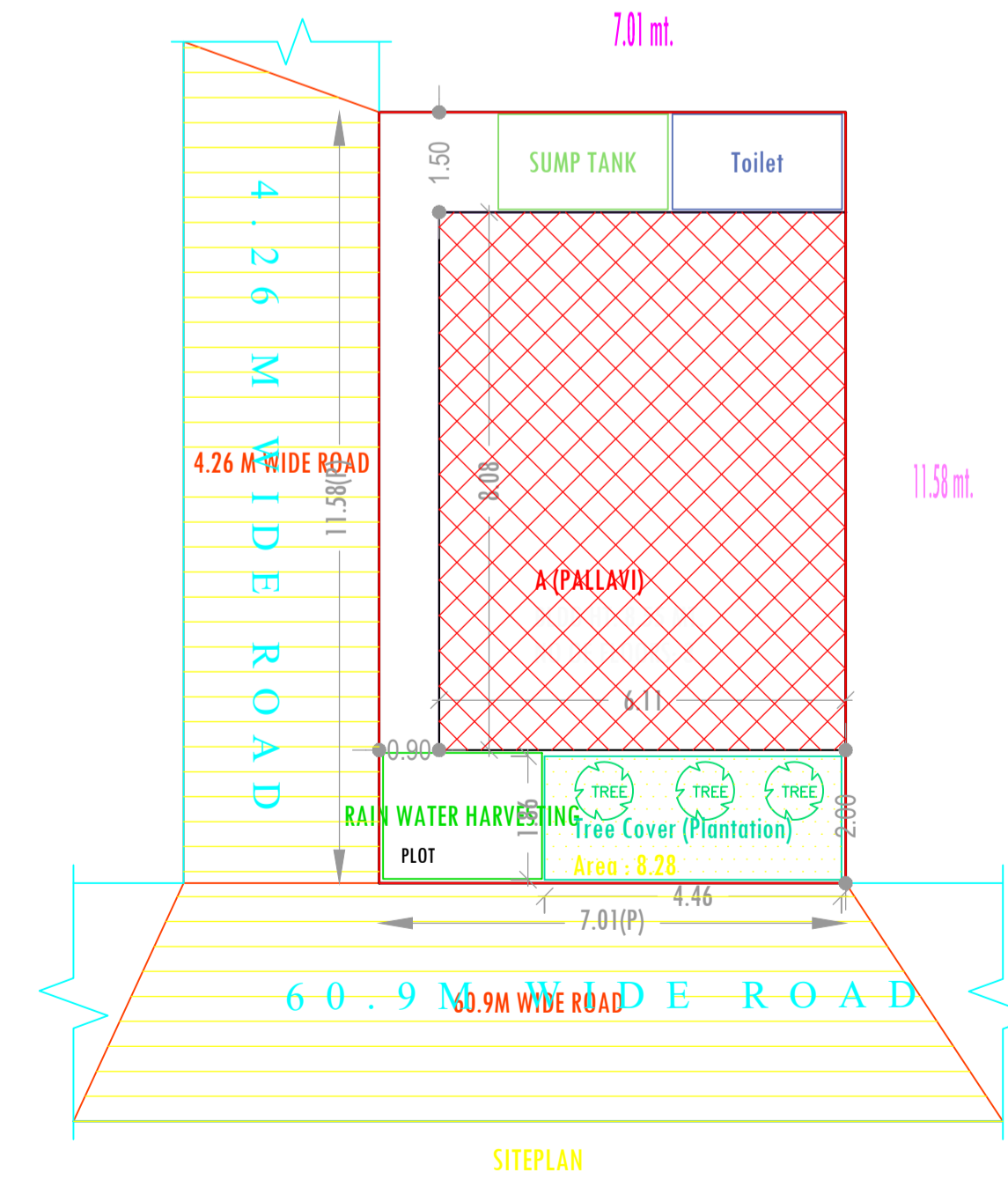

SITEPLAN

AREA STATEMENT		VERSION NO. : 1.0.21
JHUMRITILAIYA NAGAR PARISHAD		REVISION DATE: 28/09/2017
PROJECT DETAIL:		
Region: JHARKHAND URBAN LOCAL BODIES	Plot Use: Residential	
District: KODERMA	Plot SubUse: Residential Bldg/Apartment	
Authority: JHUMRITILAIYA NAGAR PARISHAD	PlotNearby/ReligiousStructure: NA	
Inward No: JNP/BP/0009/W01/2018	PlotSubPlot No: 3950	
Application Type: General Proposal	North: Plot No. - LAND OF SRI RAHUL KUMAR	
Project Type: Building Permission	South: Road Width - 4.26M WIDE ROAD	
Nature of Development: New	East: Road Width - 60.9M WIDE ROAD	
Location of Development Area: Old Area	West: Plot No. - GAYTRI HOSPITAL	
AREA DETAILS:		SQ.MT.
AREA OF PLOT (Minimum)	(A)	81.14
NET AREA OF PLOT(Gross Plot Area - Deduction from Gross Plot area)	(A-Deductions)	81.14
Deduction for Balance Plot Area(from Gross Plot Area)		
Common Plot		8.28
Total		8.28
BALANCE AREA OF PLOT(Net Plot Area - Recreational/Amenity space)	(A-Deductions)	72.86
PLOT AREA FOR COVERAGE(Net Plot Area)	(A-Deductions)	81.14
Plot Area for FAR (Net Plot Area + Road/Widening Area)	(A-Deductions)	81.14
COVERAGE CHECK		
Permissible Coverage area (70.00 %)		56.80
Proposed Coverage Area (60.82 %)		49.35
Total Prop. Coverage area (60.82 %)		49.35
Balance coverage area (9.18 %)		7.45
FAR CHECK		
Perm. FAR Area (2.00)		162.28
Total Perm. FAR area		162.28
Residential FAR		98.69
Proposed FAR Area		107.79
Total Proposed FAR Area		107.79
Consumed FAR (Factor)		1.33
Balance FAR Area		54.49
BUILT UP AREA CHECK		
Total Proposed BuiltUp Area		148.05
ARCHITECT (Regd)	MD SYEED ALAM ANSARI	
ENGINEER (Regd)		
SUPERVISOR (Regd)		
OWNER (Regd)	SMT PALLAVI	
DEVELOPMENT AUTHORITY		LOCAL BODY

LTP NAME AND SIGNATURE	STRUCTURAL ENG'S NAME AND SIGNATURE	BUILDER NAME AND SIGNATURE
MD SYEED ALAM ANSARI JNP/ARC/0003/2017		