

COLOR INDEX	
PLOT BOUNDARY	Black
ABUTTING ROAD	Green
PROPOSED CONSTRUCTION	Red
COMMON PLOT	Yellow
ROAD WIDENING AREA	Orange
EXISTING (To be retained)	Blue
EXISTING (To be demolished)	Light Blue

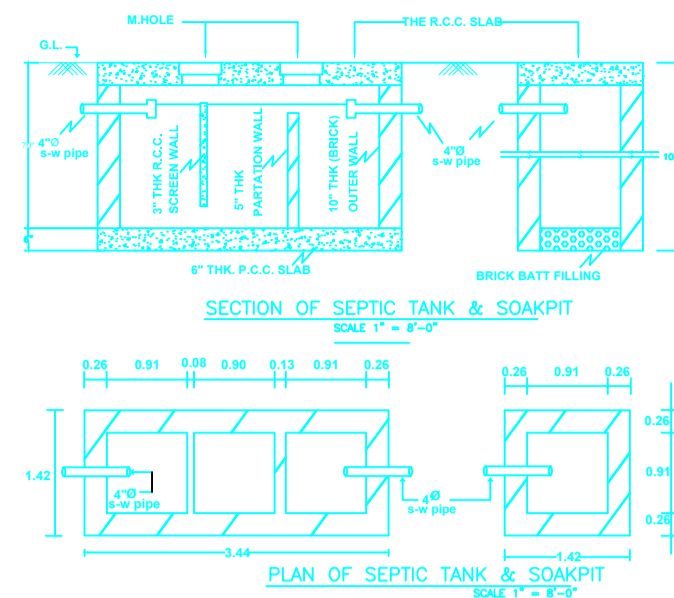

SCHEDULE OF DOOR:

BUILDING NAME	NAME	LENGTH	HEIGHT	NOS
A (SMT INDRANI DEVI)	D2	0.75	2.10	04
A (SMT INDRANI DEVI)	D1	0.90	2.10	04
A (SMT INDRANI DEVI)	D	0.95	2.10	01
A (SMT INDRANI DEVI)	D	1.00	2.10	08

SCHEDULE OF WINDOW/VENTILATION:

BUILDING NAME	NAME	LENGTH	HEIGHT	NOS
A (SMT INDRANI DEVI)	V	0.60	0.60	04
A (SMT INDRANI DEVI)	W2	0.90	1.20	04
A (SMT INDRANI DEVI)	W1	1.21	1.20	11
A (SMT INDRANI DEVI)	W	1.80	1.20	02

Building :A (SMT INDRANI DEVI)

Floor Name	Total Built Up Area (Sq.mt.)	Deductions (Area in Sq.mt.)		Proposed FAR Area (Sq.mt.)	Total FAR Area (Sq.mt.)	Total Consumed Additional FAR Area (Sq.mt.)	Tnmt (No.)
		Void	Resi.				
Ground Floor	115.21	2.12	113.09	113.09	113.09		01
First Floor	112.34	2.12	110.22	110.22	110.22		00
Terrace Floor	0.00	0.00	0.00	0.00	0.00		00
Total :	227.55	4.24	223.31	223.31	223.31		01
Total Number of Same Buildings :	1						
Total :	227.55	4.24	223.31	223.31	223.31		01

UnitBUA Table for Building :A (SMT INDRANI DEVI)

FLOOR	Name	UnitBUA Type	UnitBUA Area	Carpet Area	No. of Rooms	No. of Tenement
GROUND FLOOR PLAN	SPLIT FLAT A	FLAT	160.90	153.75	8	1
FIRST FLOOR PLAN	SPLIT FLAT A	FLAT	0.00	0.00	9	0
Total :	-	-	160.90	153.75	17	1

Buildingwise Floor FAR Details

Floor Name	Building Name A (SMT INDRANI DEVI)		Total	
	Proposed Built Up Area (Sq.mt.)	Proposed FAR Area (Sq.mt.)	Total Proposed Built Up Area (Sq.mt.)	Total FAR Area (Sq.mt.)
Ground Floor	115.21	113.09	115.21	113.09
First Floor	112.34	110.22	112.34	110.22
Terrace Floor	0.00	0.00	0.00	0.00
Total :	227.55	223.31	227.55	223.31

Building USE/SUBUSE Details

Building Name	Building Use	Building SubUse	Building Structure
A (SMT INDRANI DEVI)	Residential	Residential Bldg/Apartment	Non-Highrise

FAR & Tenement Details (Table 4c-1)

Building	No. of Same Bldg	Total Built Up Area (Sq.mt.)	Deductions (Area in Sq.mt.)		Proposed FAR Area (Sq.mt.)	Total FAR Area (Sq.mt.)	Total Consumed Additional FAR Area (Sq.mt.)	Tnmt (No.)
			Void	Resi.				
A (SMT INDRANI DEVI)	1	227.55	4.24	223.31	223.31	223.31	01	
Grand Total :	1	227.55	4.24	223.31	223.31	223.31	01	

AREA STATEMENT	VERSION NO.: 1.0.22
JHUMRITILAIYA NAGAR PARISHAD	VERSION DATE: 28/09/2017

PROJECT DETAIL:	
Region: JHARKHAND URBAN LOCAL BODIES	Plot Use: Residential
District: KODERMA	Plot SubUse: Residential Bldg/Apartment
Authority: JHUMRITILAIYA NAGAR PARISHAD	PlotNearby/ReligiousStructure: NA
Inward_No: JNP/BP/0012/W22/2018	Plot/SubPlot No: 5630
Application Type: General Proposal	North: Plot No. - CHAMARI MIYAN & SMT RENUKA BHARTI
Project Type: Building Permission	South: Plot No. - LAND OF VENDOR
Nature of Development: New	East: Road Width - 3.04 M WIDE ROAD
Location of Development Area: New Area	West: Plot No. - CHAMARI MIYAN

AREA DETAILS:		SQ.MT.
AREA OF PLOT (Minimum)	(A)	201.43
Deduction for NetPlot Area		
Road Widening Area		13.70
Total		13.70
NET AREA OF PLOT(Gross Plot Area - Deduction from Gross Plot area)	(A-Deductions)	187.72
Deduction for Balance Plot Area(from Gross Plot Area)		
Road Widening Area		13.70
Common Plot		21.47
Total		35.17
BALANCE AREA OF PLOT(Net Plot Area - Recreational/Amenity space)	(A-Deductions)	166.26
PLOT AREA FOR COVERAGE(Net Plot Area)	(A-Deductions)	187.72
Plot Area for FAR (Net Plot Area + RoadWidening Area)	(A-Deductions)	187.72
COVERAGE CHECK		
Permissible Coverage area (70.00 %)		131.41
Proposed Coverage Area (61.37 %)		115.21
Total Prop. Coverage Area (61.37 %)		115.21
Balance coverage area (8.63 %)		16.20
FAR CHECK		
Perm. FAR Area (1.20)		225.27
Total Perm. FAR area		225.27
Residential FAR		223.31
Proposed FAR Area		223.31
Total Proposed FAR Area		223.31
Consumed FAR (Factor)		1.19
Balance FAR Area		1.96
BUILT UP AREA CHECK		
Total Proposed BuiltUp Area		227.55
ARCHITECT (Regd)		MD SHOAB ALAM
ENGINEER (Regd)		
SUPERVISOR (Regd)		
OWNER (Regd)		SMT INDRANI DEVI
DEVELOPMENT AUTHORITY		LOCAL BODY

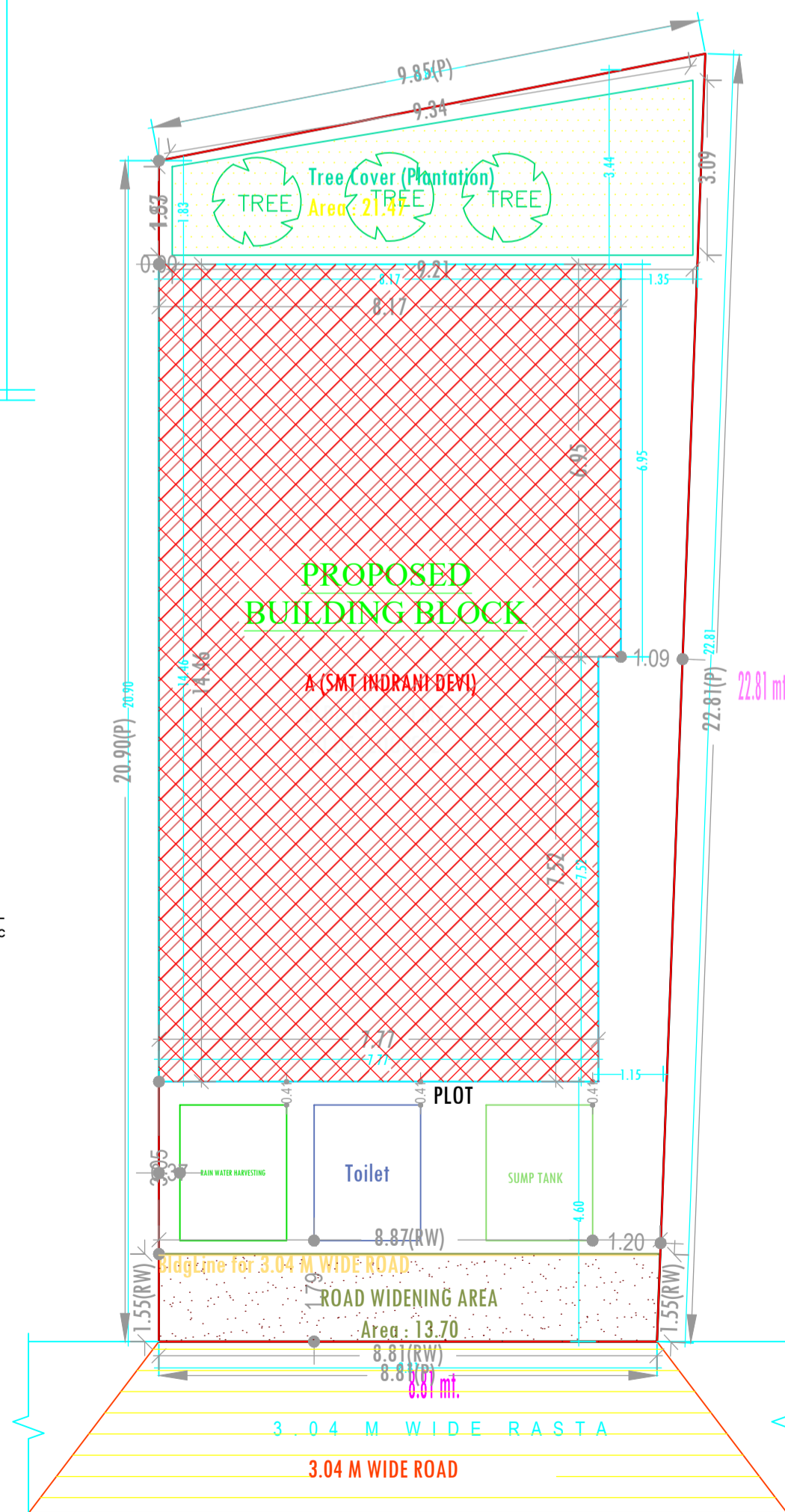
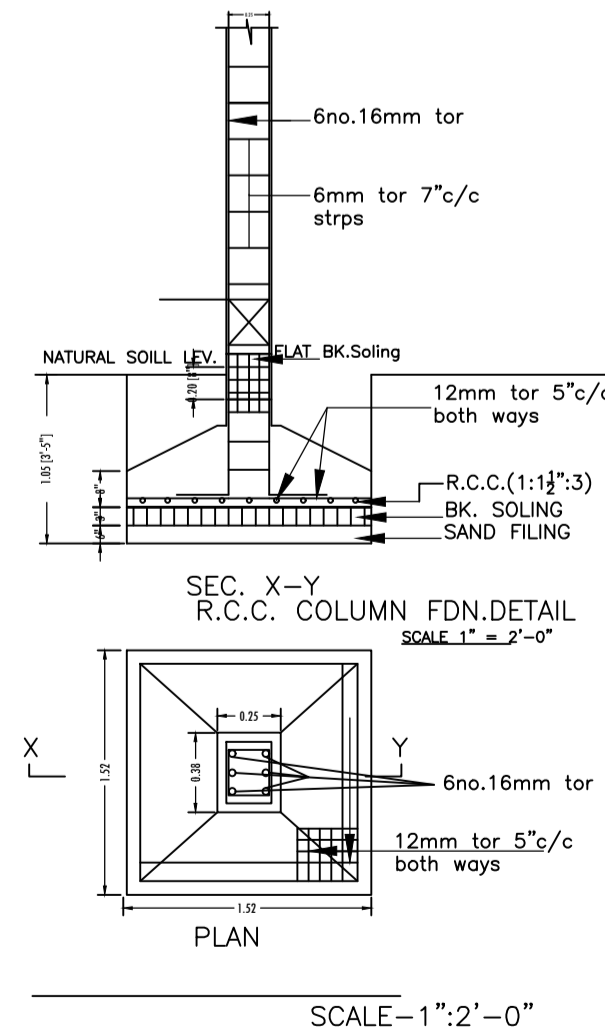
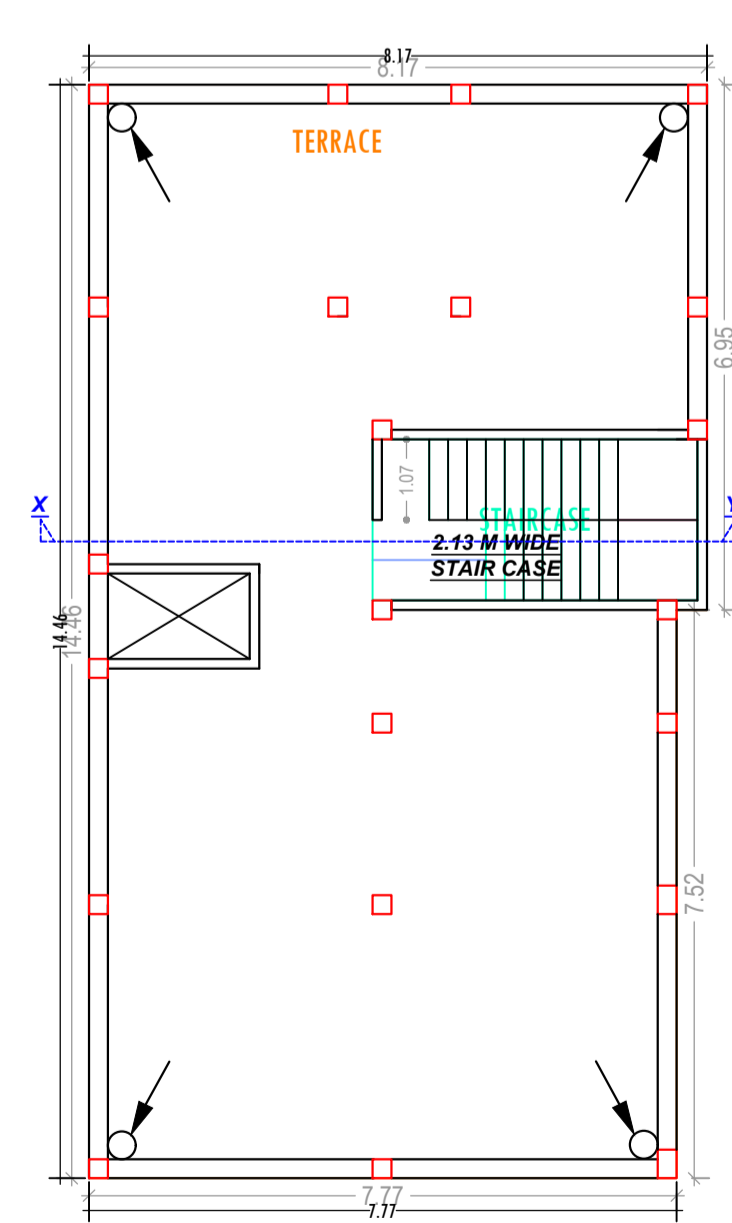
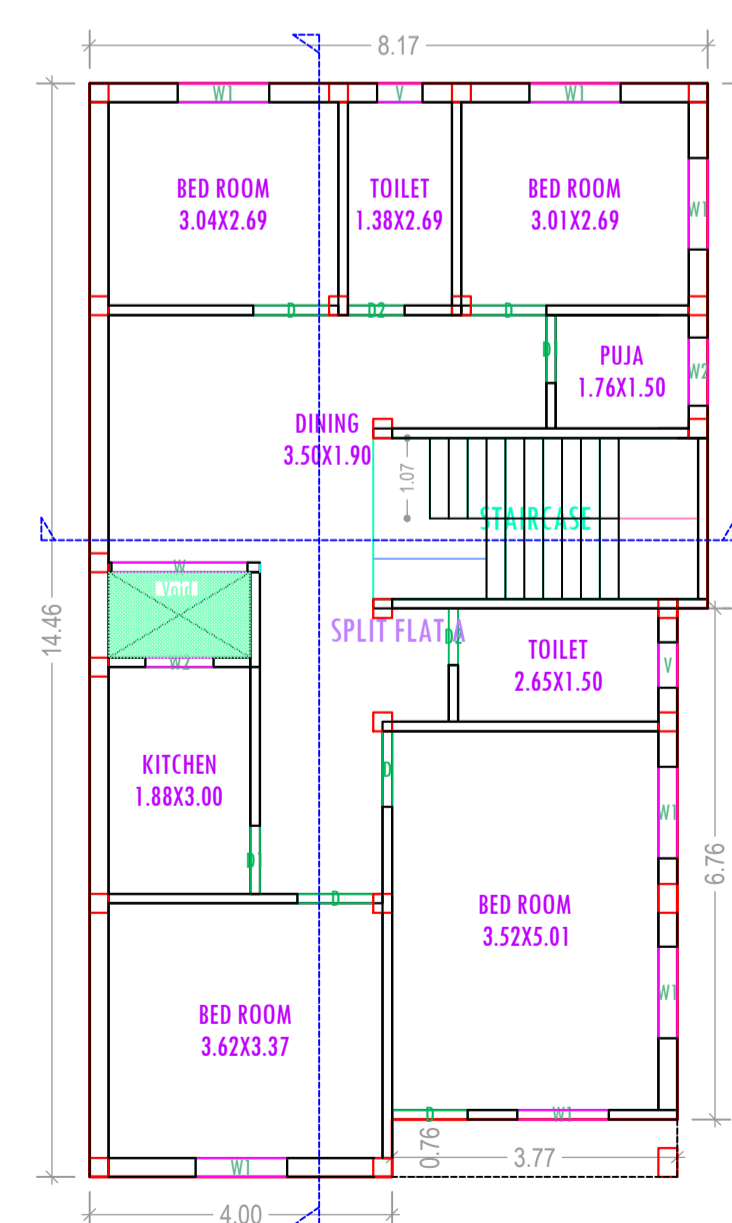
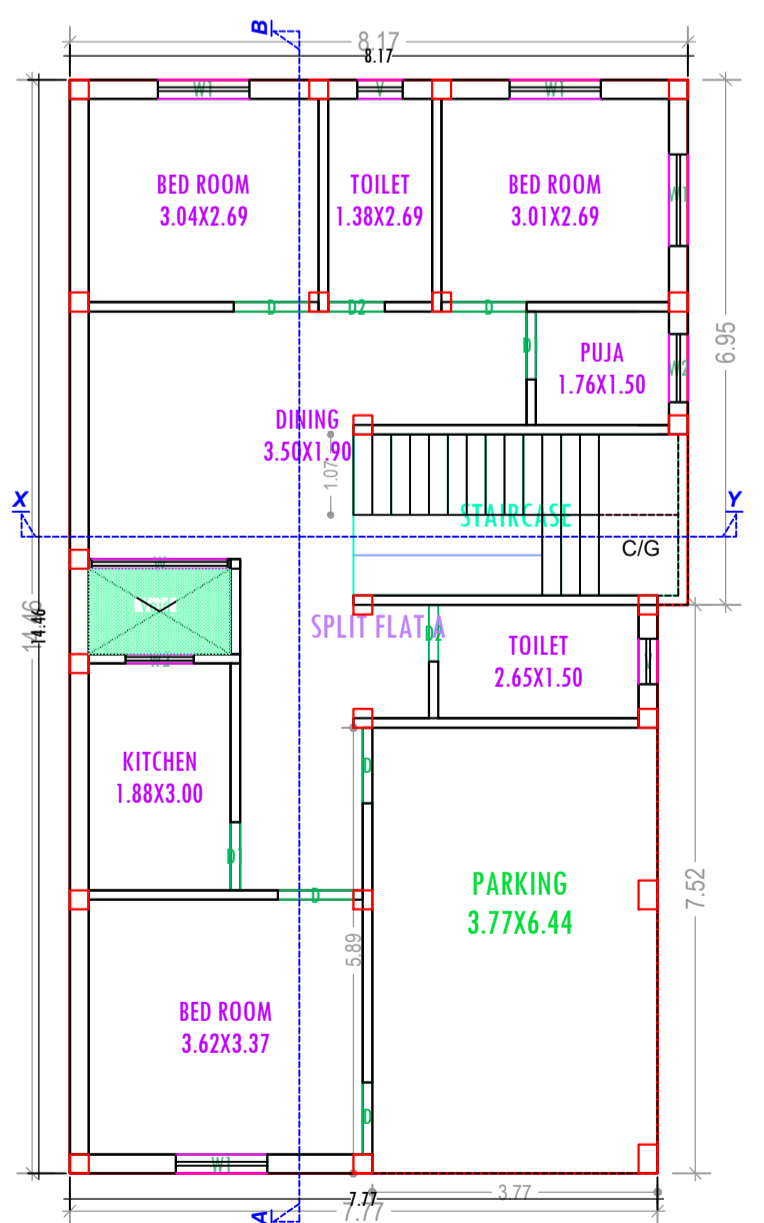
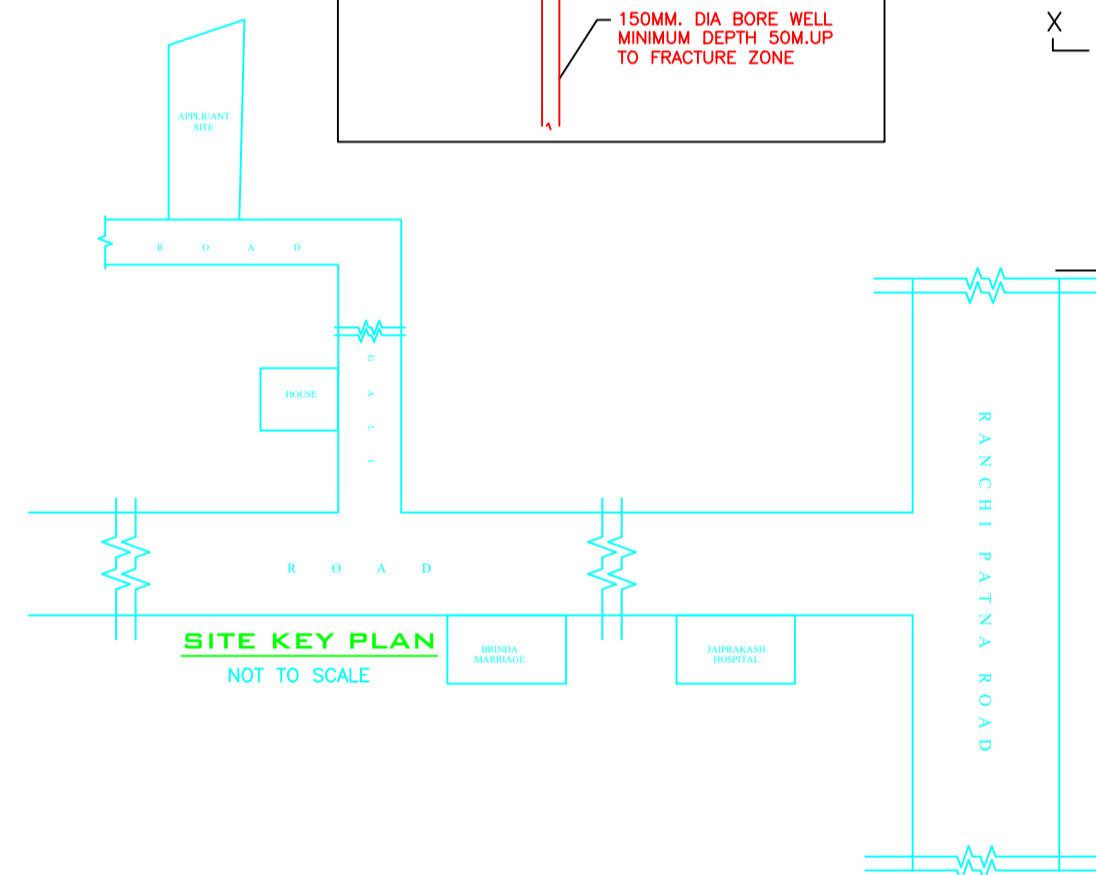
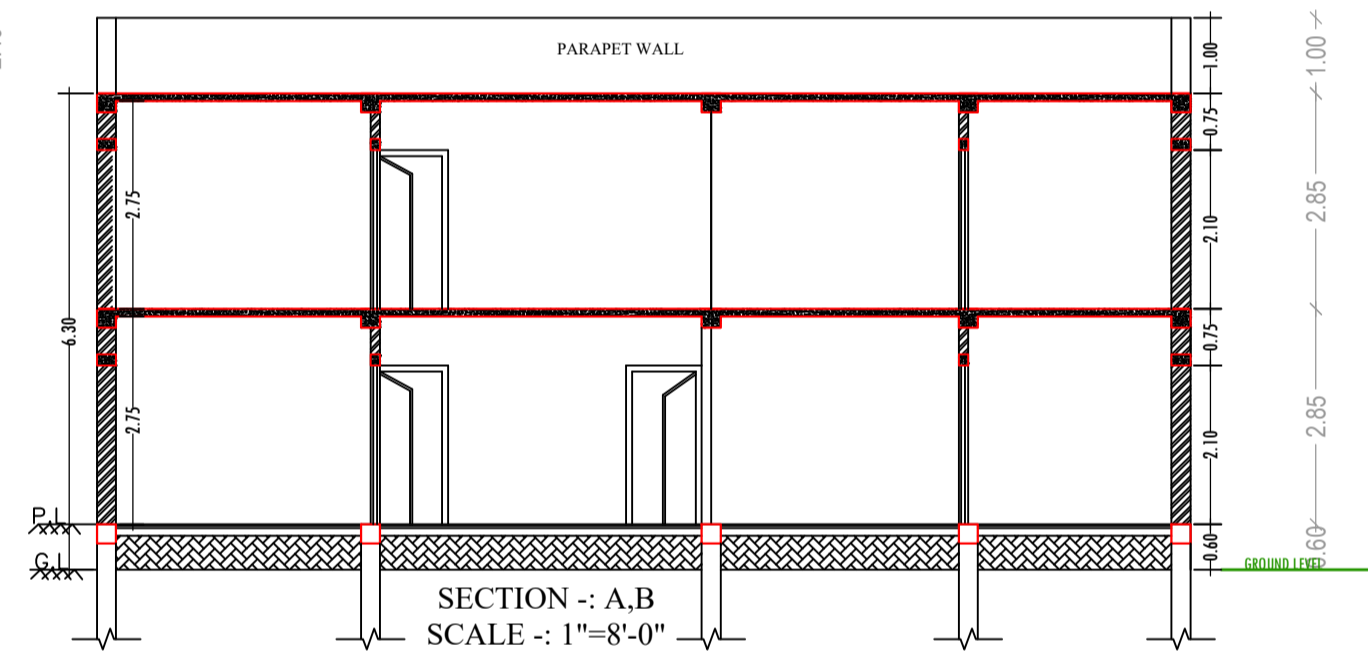
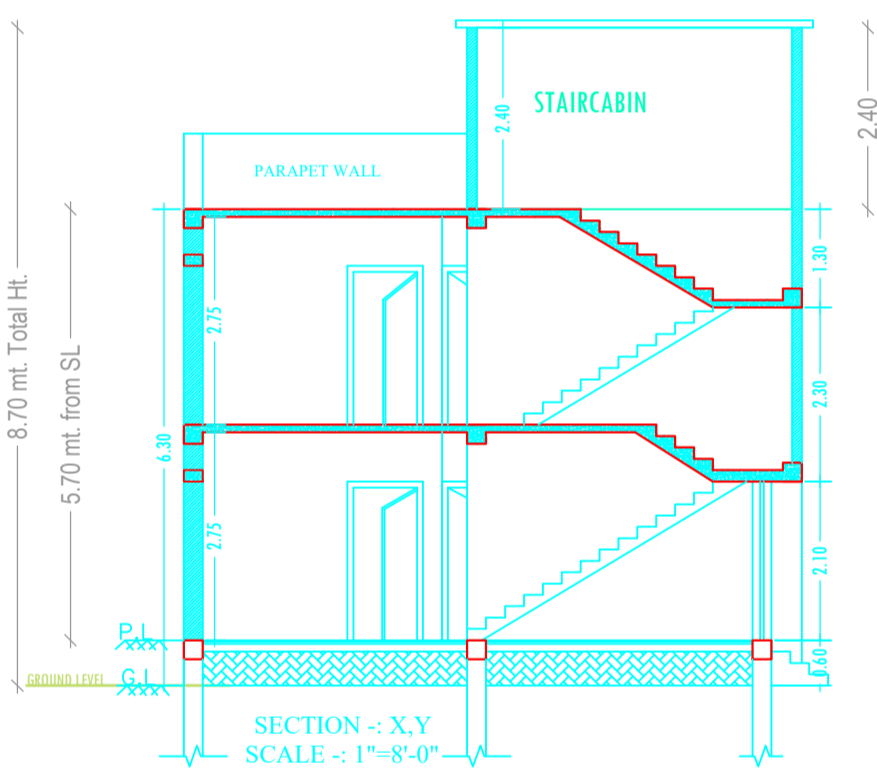
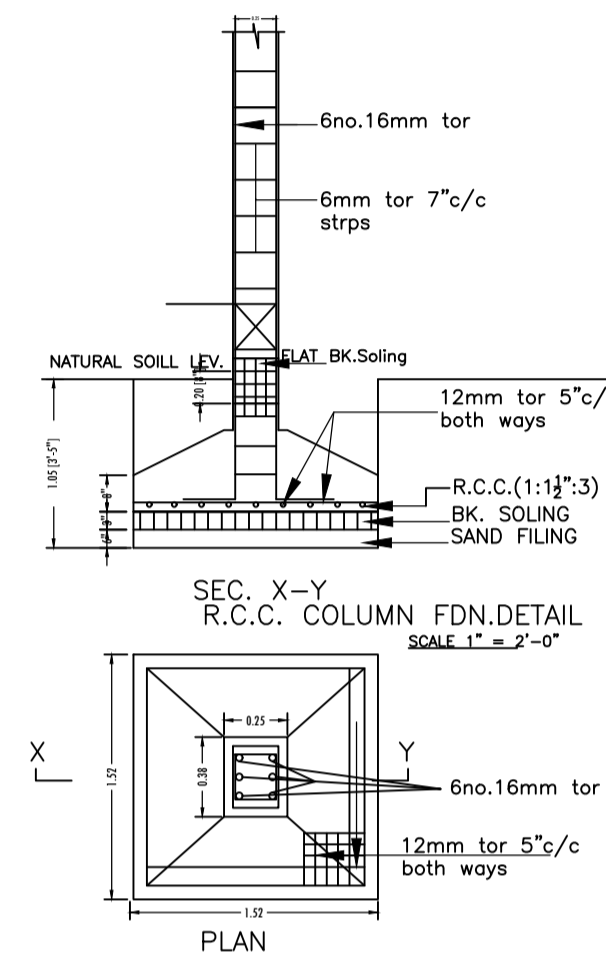
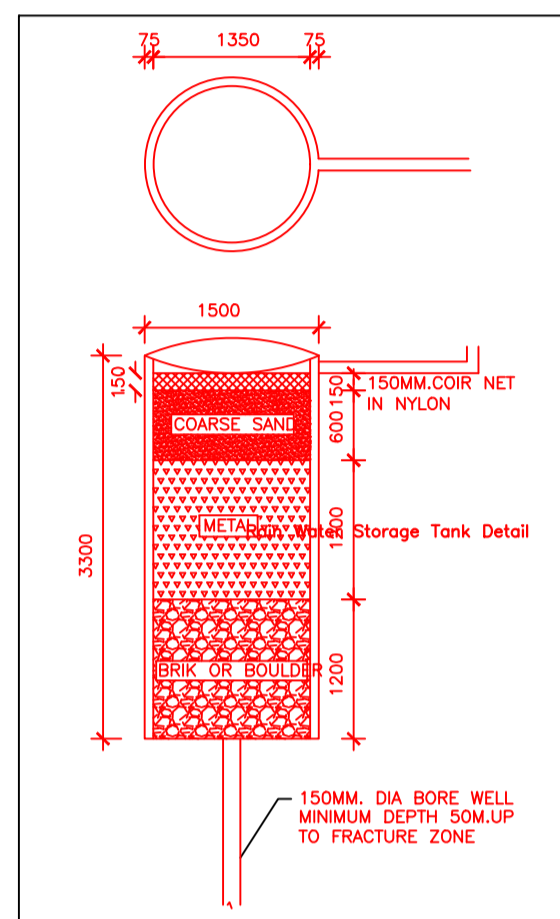
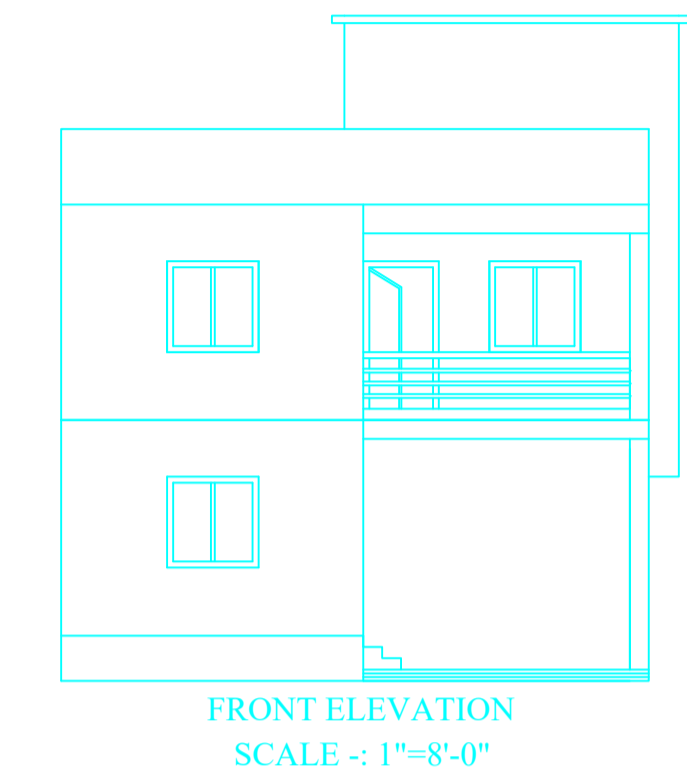

LTP NAME AND SIGNATURE	STRUCTURAL ENG'S NAME AND SIGNATURE	BUILDER NAME AND SIGNATURE
MD SHOAB ALAM JNP/ENG/0001/2017		