

Proposal Basic Information	
Proposal File No.	JNP/BP/0056/W14/2018
Owner Name	SRI AMIT KUMAR DUTTA
Khata No	381
Plot No	7121
Village Name	Tilaiya
Use	Residential
SubUse	Residential Bldg/Apartment

Buildingwise Floor FAR Details

Floor Name	Building Name A (SANDHYA DUTTA)		Total	
	Proposed Built Up Area (Sq.mt.)	Proposed FAR Area (Sq.mt.)	Total Proposed Built Up Area (Sq.mt.)	Total FAR Area (Sq.mt.)
Ground Floor	50.86	7.97	50.86	7.97
First Floor	50.15	50.15	50.15	50.15
Terrace Floor	0.00	0.00	0.00	0.00
Total :	101.01	58.12	101.01	58.12

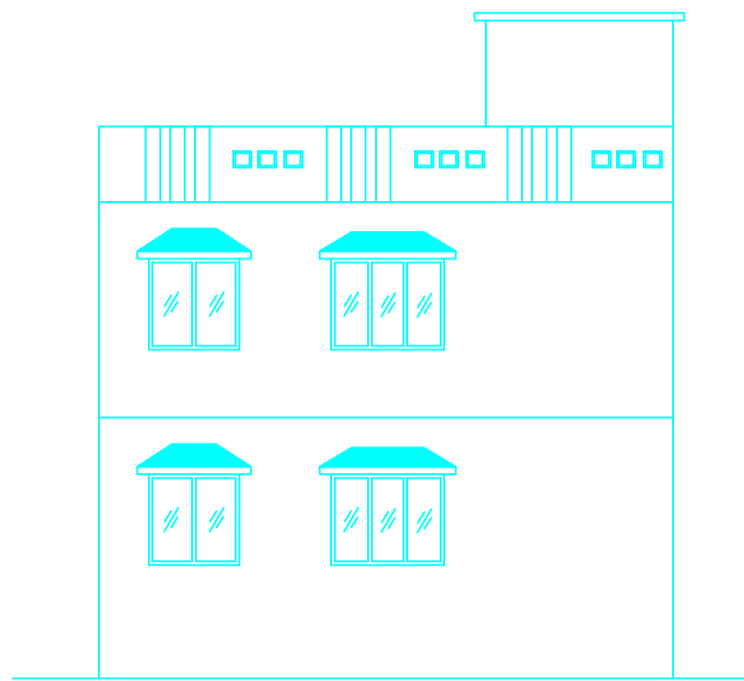

RIGHT SIDE ELEVATION
SCALE= 1:100

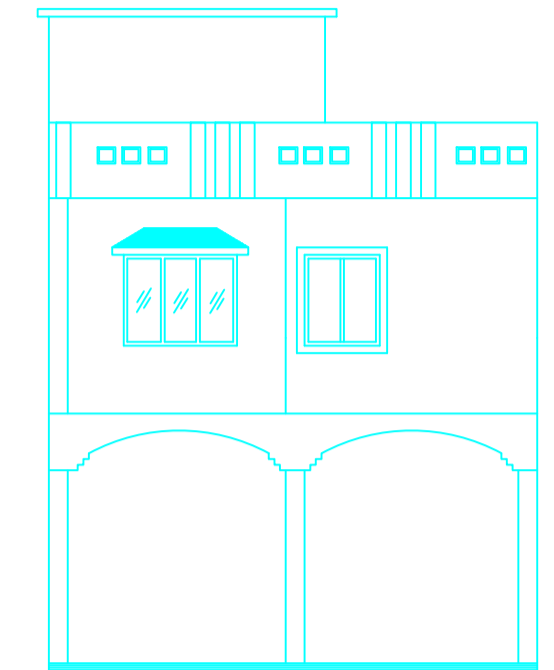

FRONT ELEVATION
SCALE= 1:100

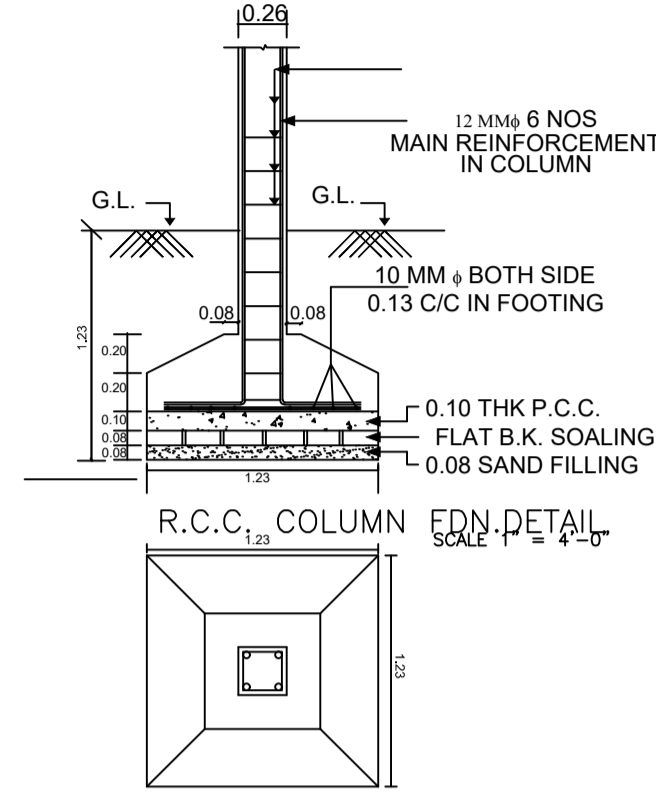

PLAN SCALE 1" = 4'-0"

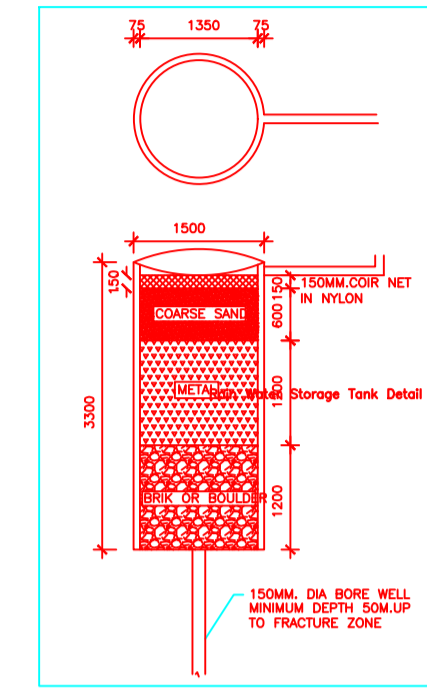

FAR & Tenement Details (Table 4c-1)

Building	No. of Same Bldg	Total Built Up Area (Sq.mt.)	Deductions (Area in Sq.mt.)	Proposed FAR Area (Sq.mt.)	Add Area in FAR (Sq.mt.)	Total FAR Area (Sq.mt.)	Total Consumed Additional FAR Area (Sq.mt.)	Tnmt (No.)
A (SANDHYA DUTTA)	1	101.01	42.89	50.15	7.97	58.12	58.12	01
Grand Total :	1	101.01	42.89	50.15	7.97	58.12	58.12	01

UnitBUA Table for Building :A (SANDHYA DUTTA)

FLOOR	Name	UnitBUA Type	UnitBUA Area	Carpet Area	No. of Rooms	No. of Tenement
FIRST FLOOR	SPLIT FLATE A	FLAT	32.30	31.64	4	1
Total:	-	-	32.30	31.64	4	1

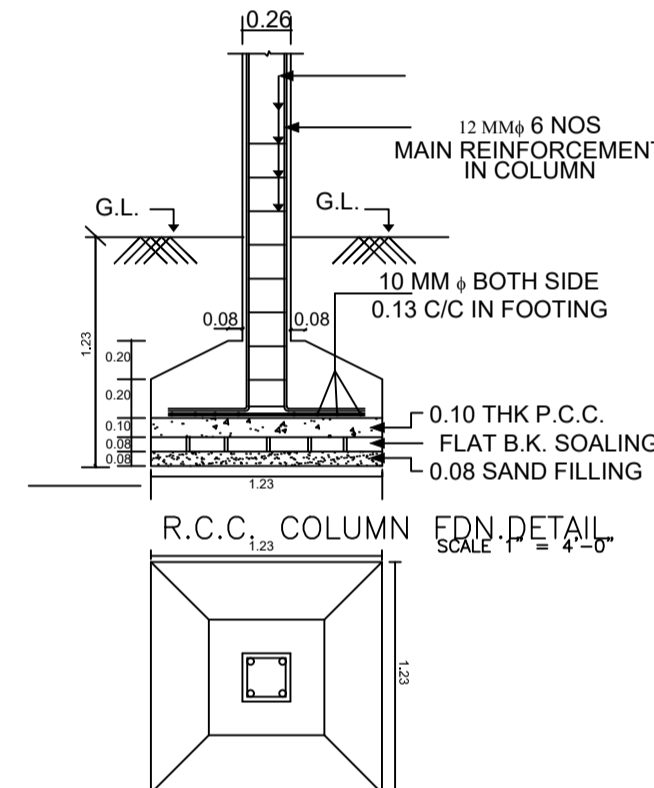

PLAN SCALE 1" = 4'-0"

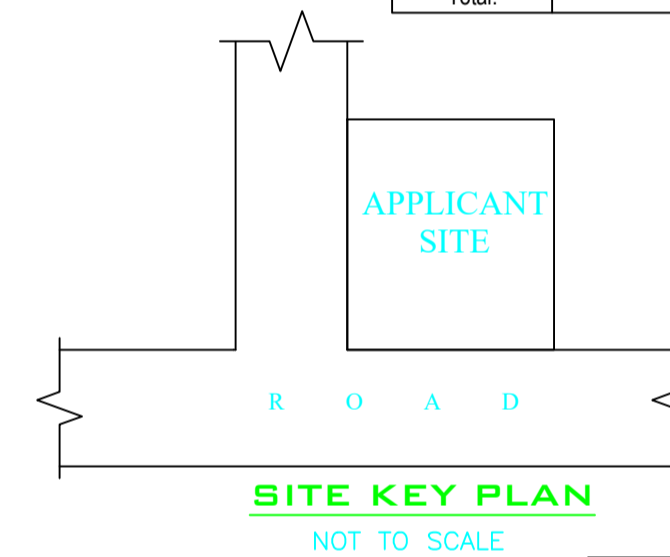

SITE KEY PLAN
NOT TO SCALE

COLOR INDEX	
PLOT BOUNDARY	Black
ABUTTING ROAD	Green
PROPOSED CONSTRUCTION	Red
COMMON PLOT	Yellow
ROAD WIDENING AREA	Blue
EXISTING (To be retained)	Light Blue
EXISTING (To be demolished)	Dark Blue

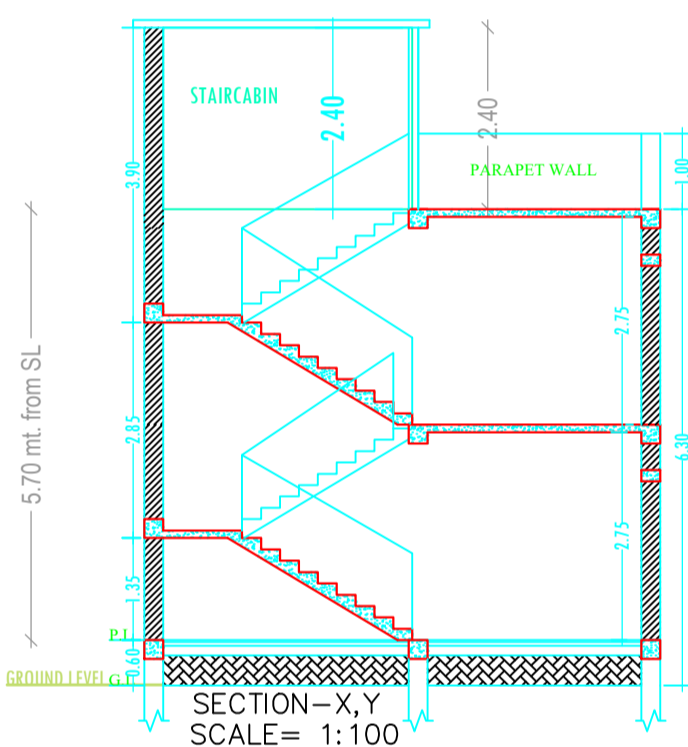

SECTION - X,Y
SCALE= 1:100

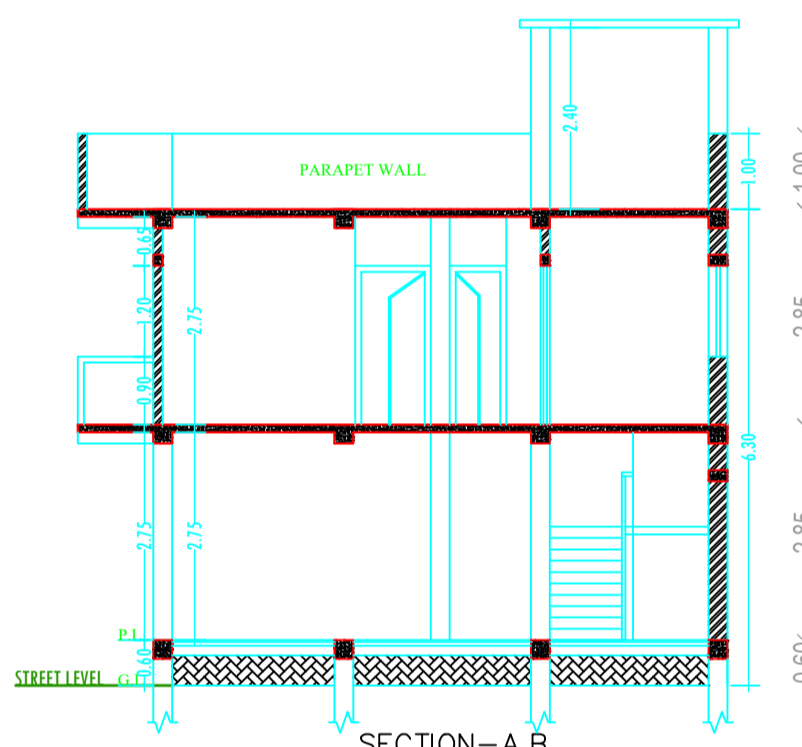

SECTION - A,B
SCALE= 1:100

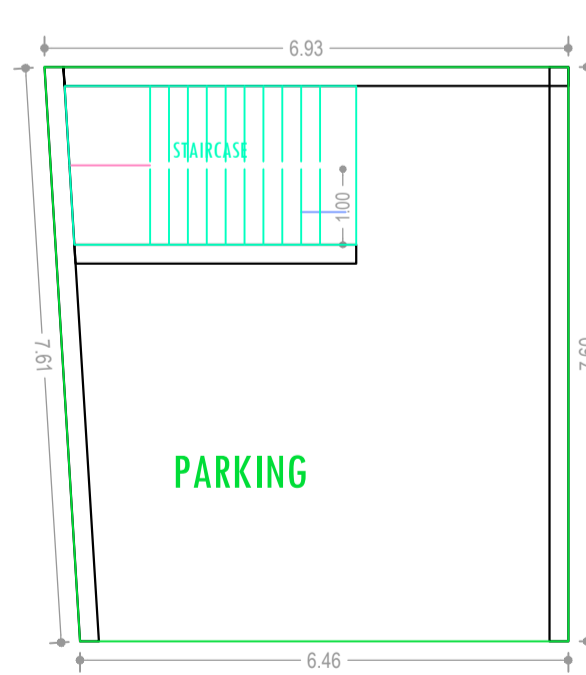

GROUND FLOOR PLAN
SCALE 1:100

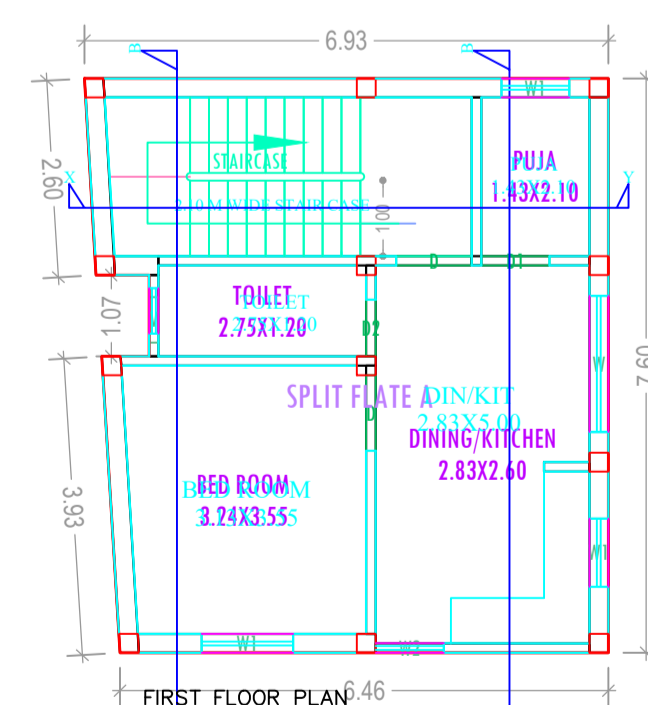

FIRST FLOOR PLAN
(Proposed)
SCALE 1:100

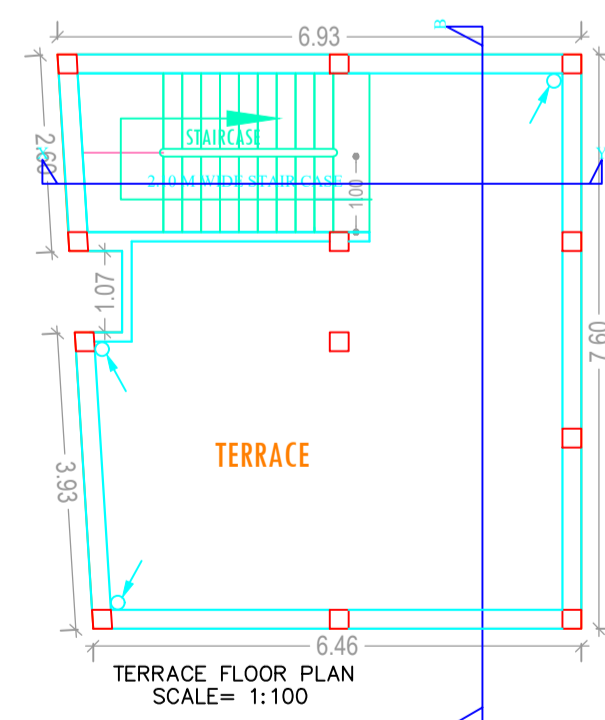

TERRACE FLOOR PLAN
SCALE 1:100

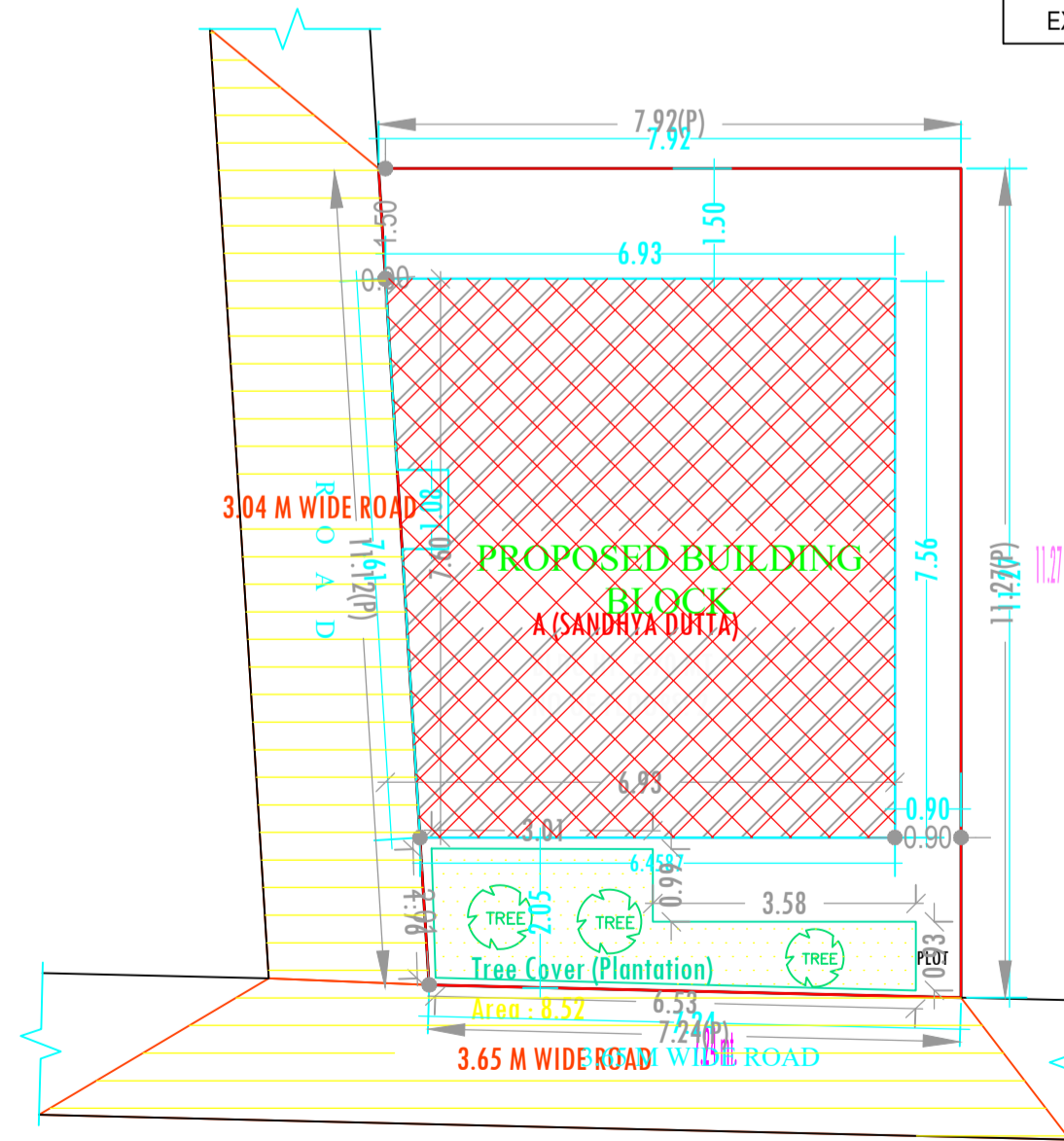

SITE PLAN
SCALE :- 1=100
SITE PLAN

Building USE/SUBUSE Details

Building Name	Building Use	Building SubUse	Building Structure
A (SANDHYA DUTTA)	Residential	Residential Bldg/Apartment	Non-Highrise

Building :A (SANDHYA DUTTA)

Floor Name	Total Built Up Area (Sq.mt.)	Deductions (Area in Sq.mt.)	Proposed FAR Area (Sq.mt.)	Add Area in FAR (Sq.mt.)	Total FAR Area (Sq.mt.)	Total Consumed Additional FAR Area (Sq.mt.)	Tnmt (No.)
Ground Floor	50.86	42.89	0.00	7.97	7.97	7.97	00
First Floor	50.15	0.00	50.15	0.00	50.15	50.15	01
Terrace Floor	0.00	0.00	0.00	0.00	0.00	0.00	00
Total :	101.01	42.89	50.15	7.97	58.12	58.12	01
Total Number of Same Buildings	1						
Total :	101.01	42.89	50.15	7.97	58.12	58.12	01

SCHEDULE OF DOOR:

BUILDING NAME	NAME	LENGTH	HEIGHT	NOS
A (SANDHYA DUTTA)	D2	0.75	2.10	01
A (SANDHYA DUTTA)	D1	0.90	2.10	01
A (SANDHYA DUTTA)	D	1.00	2.10	02

SCHEDULE OF WINDOW/VENTILATION:

BUILDING NAME	NAME	LENGTH	HEIGHT	NOS
A (SANDHYA DUTTA)	V	0.60	0.80	01
A (SANDHYA DUTTA)	W1	0.90	1.20	02
A (SANDHYA DUTTA)	W2	0.90	1.20	01
A (SANDHYA DUTTA)	W1	1.21	1.20	01
A (SANDHYA DUTTA)	W	1.80	1.21	01

AREA STATEMENT		VERSION NO. 1.0.28
JHUMRITILAIYA NAGAR PARISHAD		VERSION DATE: 30/06/2018
PROJECT DETAIL:		
Region: JHARKHAND URBAN LOCAL BODIES	Plot Use: Residential	
District: KODERMA	Plot SubUse: Residential Bldg/Apartment	
Authority: JHUMRITILAIYA NAGAR PARISHAD	PlotNearby/ReligiousStructure: NA	
Inward_No: JNP/BP/0056/W14/2018	Plot/SubPlot No: 7121	
Application Type: General Proposal	North: Plot No. - SINGH JEE	
Project Type: Building Permission	South: Road Width - 3.65M WIDE ROAD	
Nature of Development: New	East: Plot No. - SANDHYA DUTTA	
Location of Development Area: Old Area	West: Road Width - 3.04M WIDE ROAD	
AREA DETAILS:		
AREA OF PLOT (Minimum)	(A)	SQ.MT. 84.75
NET AREA OF PLOT(Gross Plot Area - Deduction from Gross Plot area)	(A-Deductions)	84.75
Deduction for Balance Plot Area(from Gross Plot Area)		
Common Plot		8.52
Total		8.52
BALANCE AREA OF PLOT(Net Plot Area - Recreational/Amenity space)	(A-Deductions)	76.23
PLOT AREA FOR COVERAGE(Net Plot Area)	(A-Deductions)	84.75
Plot Area for FAR (Net Plot Area + Road/Widening Area)	(A-Deductions)	84.75
COVERAGE CHECK		
Permissible Coverage area (70.00 %)		59.33
Proposed Coverage Area (60.00 %)		50.85
Total Prop. Coverage Area (60 %)		50.85
Balance coverage area (10.01 %)		8.48
FAR CHECK		
Perm. FAR Area (1.50)		127.13
Total Perm. FAR area		127.13
Residential FAR		50.15
Proposed FAR Area		58.12
Total Proposed FAR Area		58.12
Consumed FAR (Factor)		0.69
Balance FAR Area		69.01
BUILT UP AREA CHECK		
Total Proposed BuiltUp Area		101.01
ARCHITECT (Regd)	MD SHOAB ALAM	
ENGINEER (Regd)		
SUPERVISOR (Regd)		
OWNER (Regd)	SRI AMIT KUMAR DUTTA	
DEVELOPMENT AUTHORITY		LOCAL BODY

LTP NAME AND SIGNATURE	STRUCTURAL ENG'S NAME AND SIGNATURE	BUILDER NAME AND SIGNATURE
MD SHOAB ALAM JNP/ENG/0001/2017		