

COLOR INDEX

PLOT BOUNDARY	Black
ABUTTING ROAD	Green
PROPOSED CONSTRUCTION	Red
COMMON PLOT	Yellow
ROAD WIDENING AREA	Orange
EXISTING (To be retained)	Blue
EXISTING (To be demolished)	White

SCHEDULE OF DOOR:

BUILDING NAME	NAME	LENGTH	HEIGHT	NOS
A (SRI BOLBAM SAW)	D2	0.76	2.13	06
A (SRI BOLBAM SAW)	D1	0.91	2.13	07
A (SRI BOLBAM SAW)	D	1.05	2.13	01

SCHEDULE OF WINDOW/VENTILATION:

BUILDING NAME	NAME	LENGTH	HEIGHT	NOS
A (SRI BOLBAM SAW)	V	0.76	1.00	03
A (SRI BOLBAM SAW)	W2	1.00	2.50	06
A (SRI BOLBAM SAW)	W1	1.80	2.50	05
A (SRI BOLBAM SAW)	W	2.00	2.50	04

Proposal Basic Information

Proposal File No.	JNP/BP/0044/W22/2018
Owner Name	SRI BOLBAM SAW
Khata No	349
Plot No	1101
Village Name	Gomo
Use	Residential
SubUse	Bungalow/ Dwelling / Non Apartment

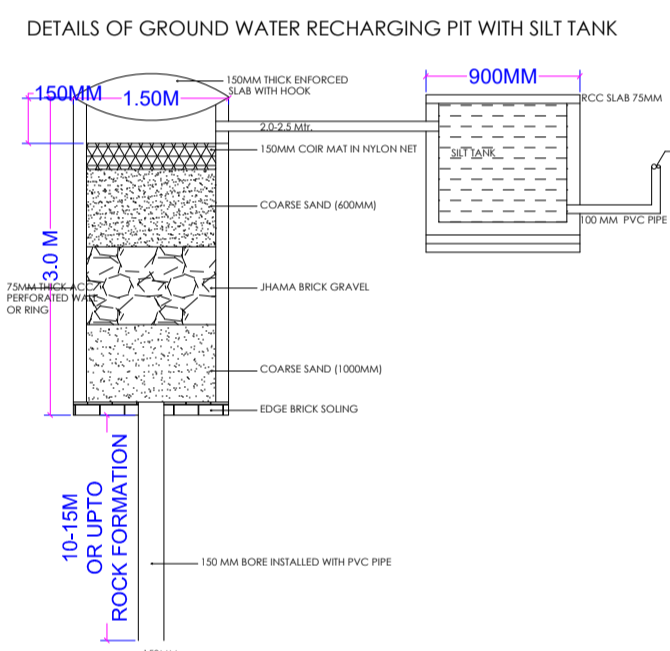
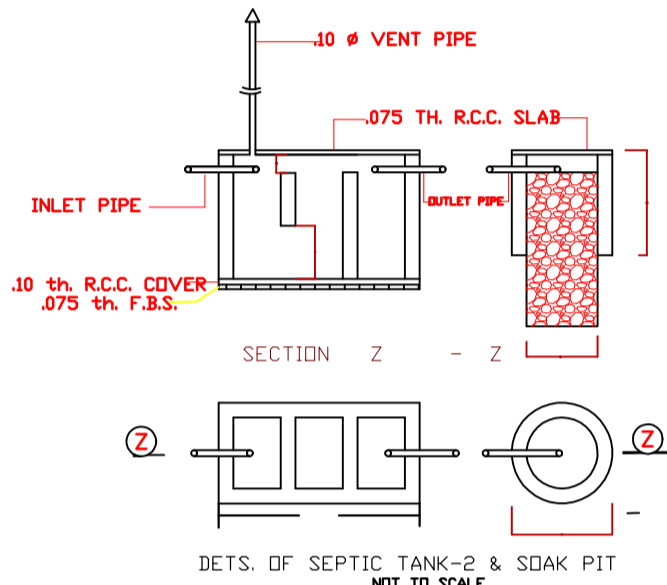
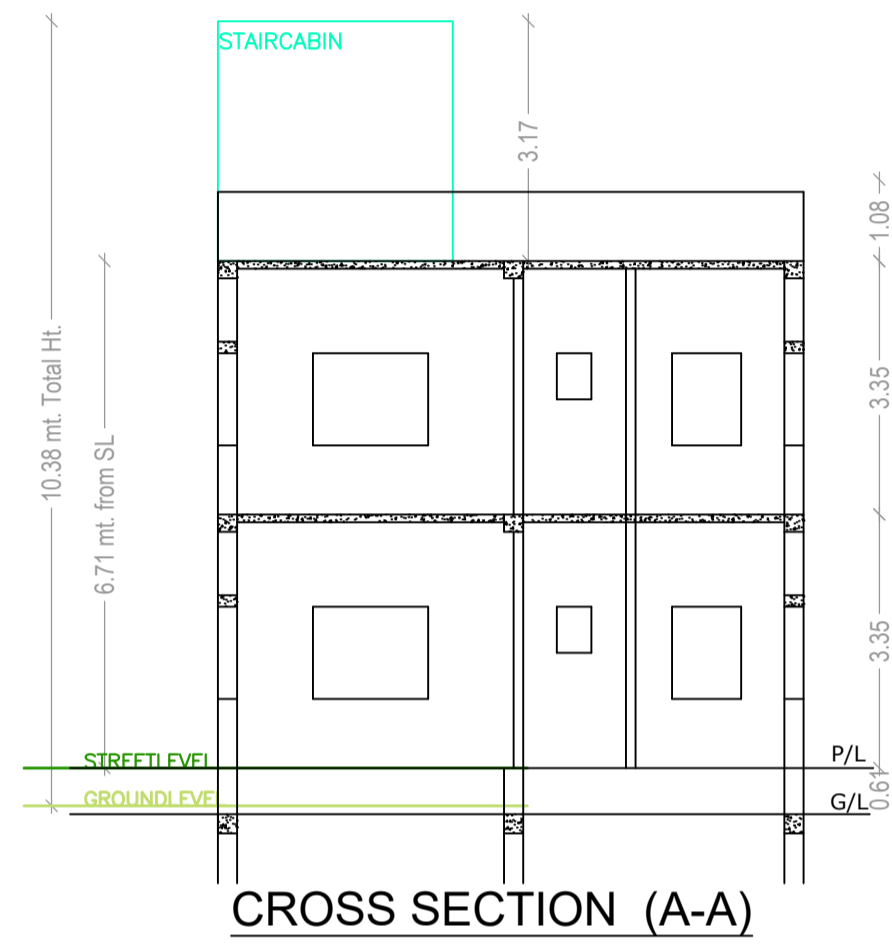

FAR & Tenement Details (Table 4c-1)

Building	No. of Same Bldg	Total Built Up Area (Sq.mt.)	Proposed FAR Area (Sq.mt.) Resi.	Total FAR Area (Sq.mt.)	Total Consumed Additional FAR Area (Sq.mt.)	Tnmt (No.)
A (SRI BOLBAM SAW)	1	190.02	190.02	190.02	190.02	01
Grand Total:	1	190.02	190.02	190.02	190.02	01

Building USE/SUBUSE Details

Building Name	Building Use	Building SubUse	Building Structure
A (SRI BOLBAM SAW)	Residential	Residential Bldg/Apartment	Non-Highrise

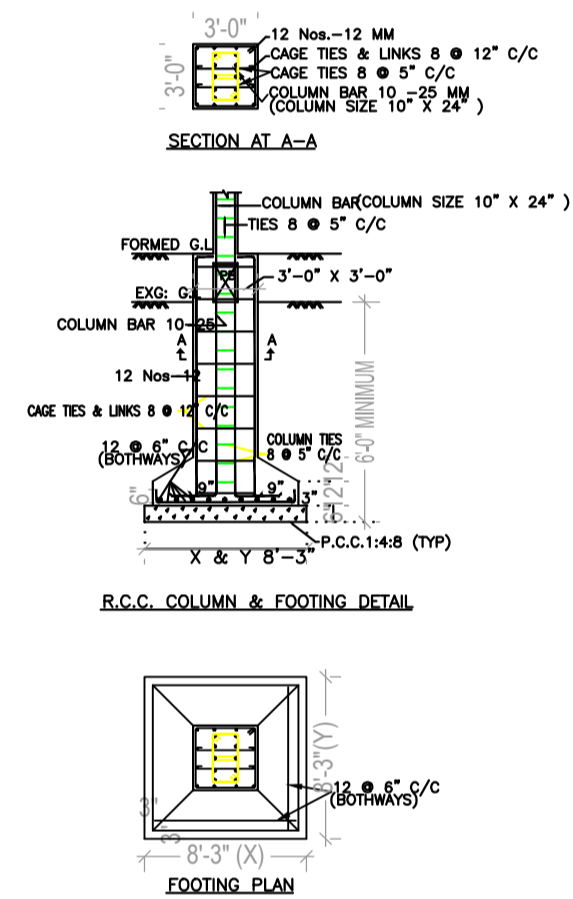

Building :A (SRI BOLBAM SAW)

Floor Name	Total Built Up Area (Sq.mt.)	Proposed FAR Area (Sq.mt.) Resi.	Total FAR Area (Sq.mt.)	Total Consumed Additional FAR Area (Sq.mt.)	Tnmt (No.)
Ground Floor	95.01	95.01	95.01	95.01	01
First Floor	95.01	95.01	95.01	95.01	00
Terrace Floor	0.00	0.00	0.00	0.00	00
Total:	190.02	190.02	190.02	190.02	01
Total Number of Same Buildings	1				
Total:	190.02	190.02	190.02	190.02	01

UnitBUA Table for Building :A (SRI BOLBAM SAW)

FLOOR	Name	UnitBUA Type	UnitBUA Area	Carpet Area	No. of Rooms	No. of Tenement
GROUND FLOOR PLAN	SPLIT SRI BOLBAM SAW	FLAT	156.11	149.61	6	1
FIRST FLOOR PLAN	SPLIT SRI BOLBAM SAW	FLAT	0.00	0.00	9	0
Total:	-	-	156.11	149.61	15	1

Buildingwise Floor FAR Details

Floor Name	Building Name A (SRI BOLBAM SAW)		Total	
	Proposed Built Up Area (Sq.mt.)	Proposed FAR Area (Sq.mt.)	Total Proposed Built Up Area (Sq.mt.)	Total FAR Area (Sq.mt.)
Ground Floor	95.01	95.01	95.01	95.01
First Floor	95.01	95.01	95.01	95.01
Terrace Floor	0.00	0.00	0.00	0.00
Total:	190.02	190.02	190.02	190.02

AREA STATEMENT
JHUMRITILAIYA NAGAR PARISHAD
PROJECT DETAIL:
Region: JHARKHAND URBAN LOCAL BODIES
District: KODERMA
Authority: JHUMRITILAIYA NAGAR PARISHAD
Inward No: JNP/BP/0044/W22/2018
Application Type: General Proposal
Project Type: Building Permission
Nature of Development: New
Location of Development Area: Old Area

VERSION NO.: 1.0.28
VERSION DATE: 30/06/2018

Plot Use: Residential
Plot SubUse: Bungalow/ Dwelling / Non Apartment
PlotNearbyReligiousStructure: NA
PlotSubPlot No: 1101
North: CTS No. - LAND OF MR. SUMAN KUMAR
South: CTS No. - SRI PANKAJ SAHAY
East: CTS No. - SRI PANKAJ SAHAY
West: Road Width - 3.66 MTR. WIDE ROAD

AREA DETAILS:	SQ.MT.
AREA OF PLOT (Minimum)	156.12
Deduction for NetPlot Area	
Surrender Free of Cost	6.19
Total	6.19
NET AREA OF PLOT(Gross Plot Area - Deduction from Gross Plot area)	149.93
Deduction for Balance Plot Area(from Gross Plot Area)	
Surrender Free of Cost	6.19
Common Plot	17.98
Total	24.17
BALANCE AREA OF PLOT(Net Plot Area - Recreational/Amenity space)	131.95
PLOT AREA FOR COVERAGE(Net Plot Area)	149.93
Plot Area for FAR (Net Plot Area + Road/Widening Area)	156.12
COVERAGE CHECK	
Permissible Coverage area (70.00 %)	104.95
Proposed Coverage Area (63.37 %)	95.01
Total Prop. Coverage Area (63.37 %)	95.01
Balance coverage area (6.63 %)	9.94
FAR CHECK	
Perm. FAR Area (1.50)	234.18
Total Perm. FAR area	234.18
Residential FAR	190.01
Proposed FAR Area	190.01
Total Proposed FAR Area	190.01
Consumed FAR (Factor)	1.22
Balance FAR Area	44.17
BUILT UP AREA CHECK	
Total Proposed BuiltUp Area	190.02
ARCHITECT (Regd)	VIKRAM INDRAJEET
ENGINEER (Regd)	
SUPERVISOR (Regd)	
OWNER (Regd)	SRI BOLBAM SAW

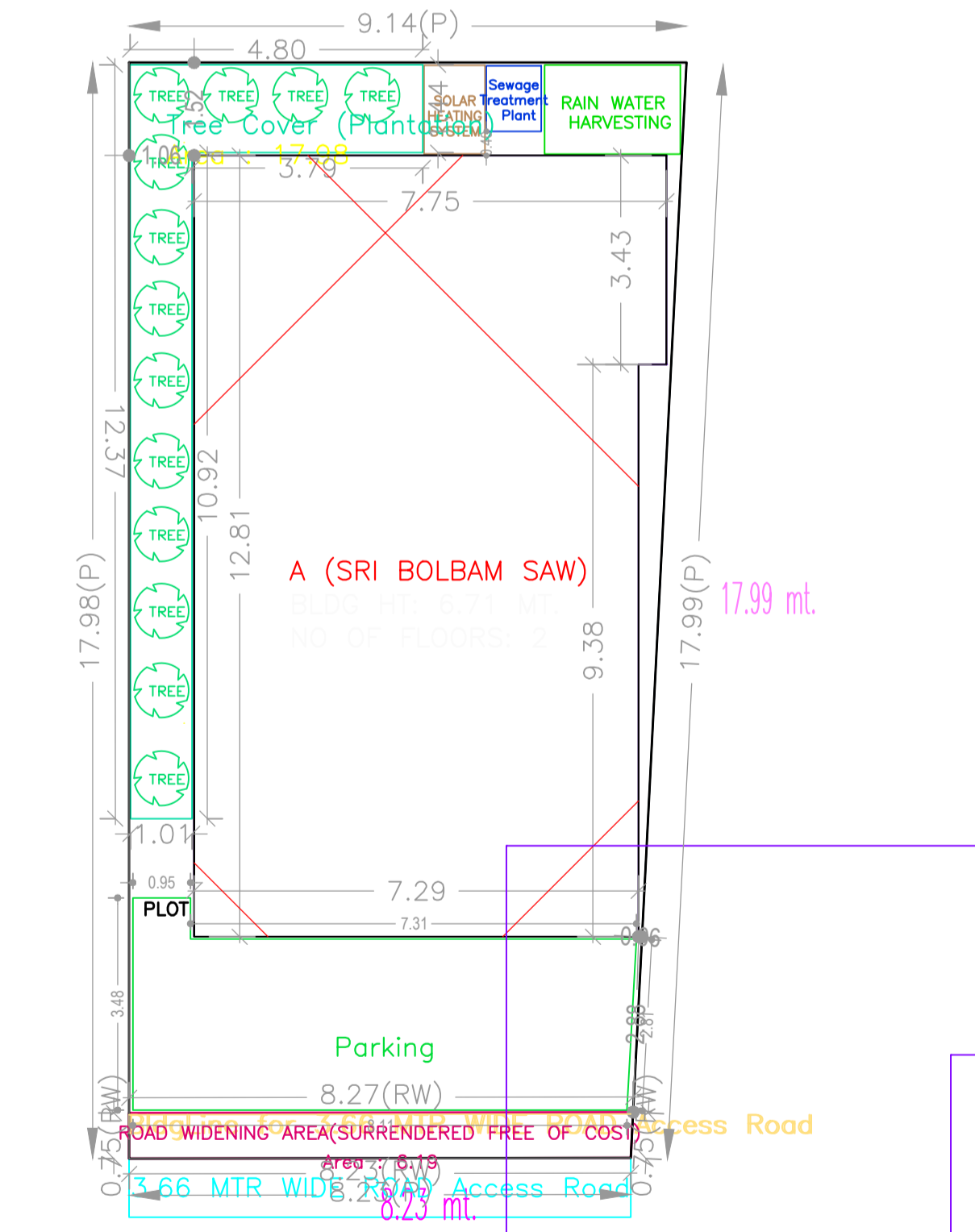
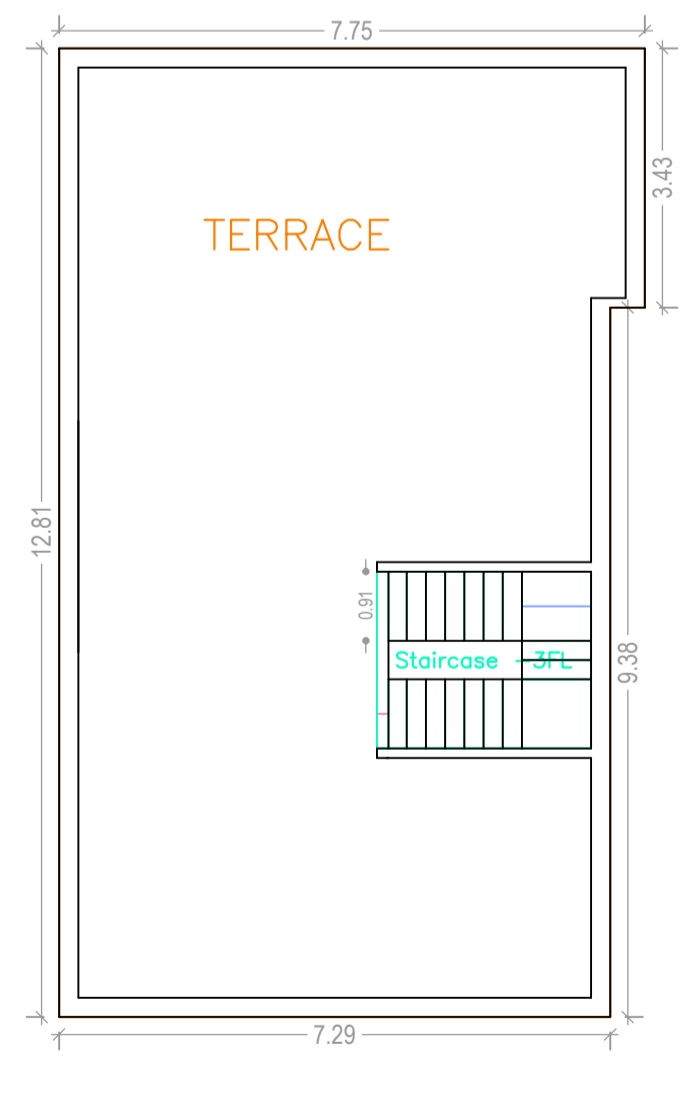
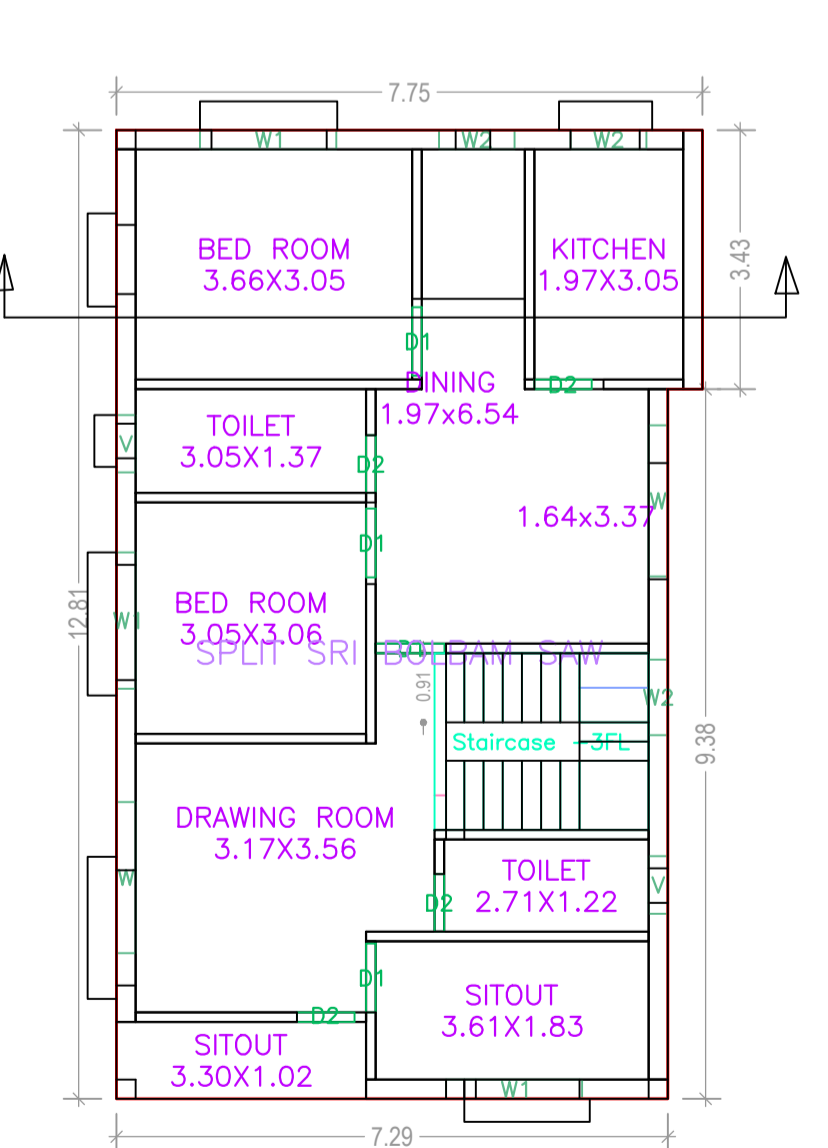
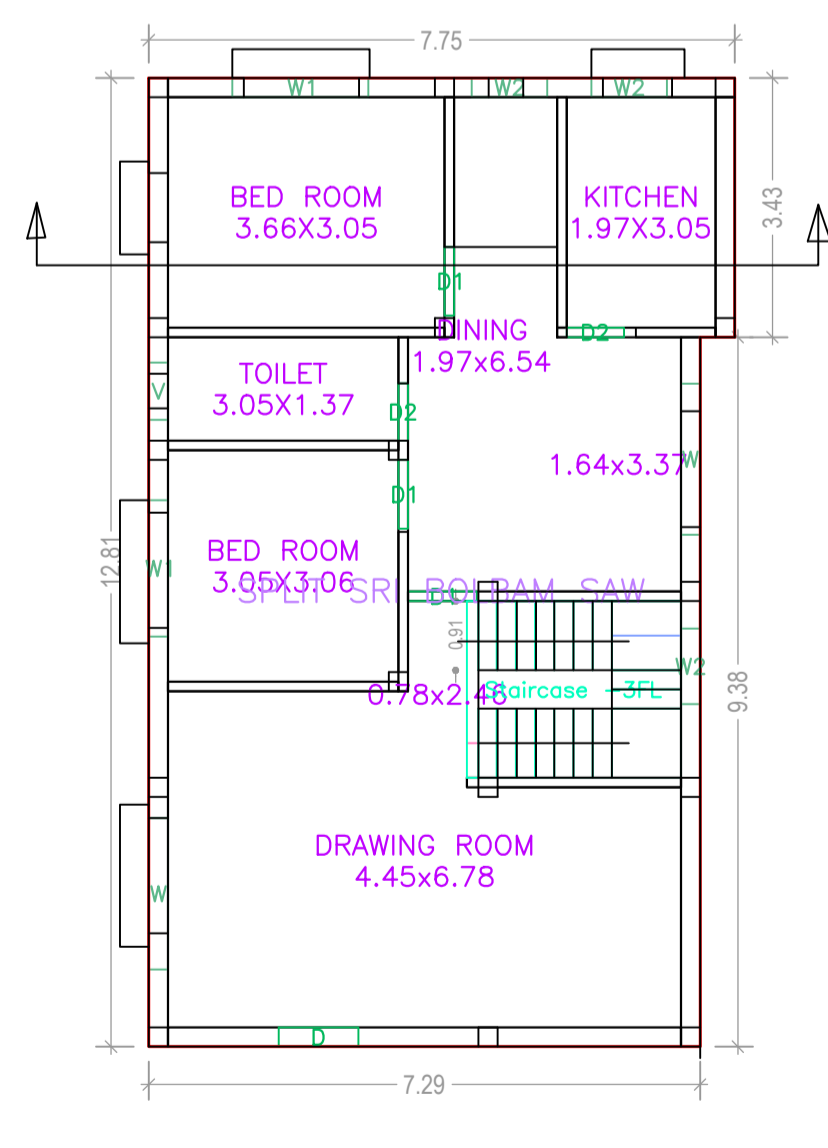

SITE PLAN