

Project Title :KABIRUDDIN

PROPOSED RESIDENTIAL BUILDING PLAN OF KABIRUDDIN S/O LATE JAGU MIYAN
AT- MOUZA - ASNA , WARD NO. 06 THANA NO.-245, THANA - TELAIYA, UNDER JHUMRI NAGAR PRISHAD
KHATA NO. - 82 PLOT NO. - 1345, DIST. OF KODERMA .(JHARKHAND)

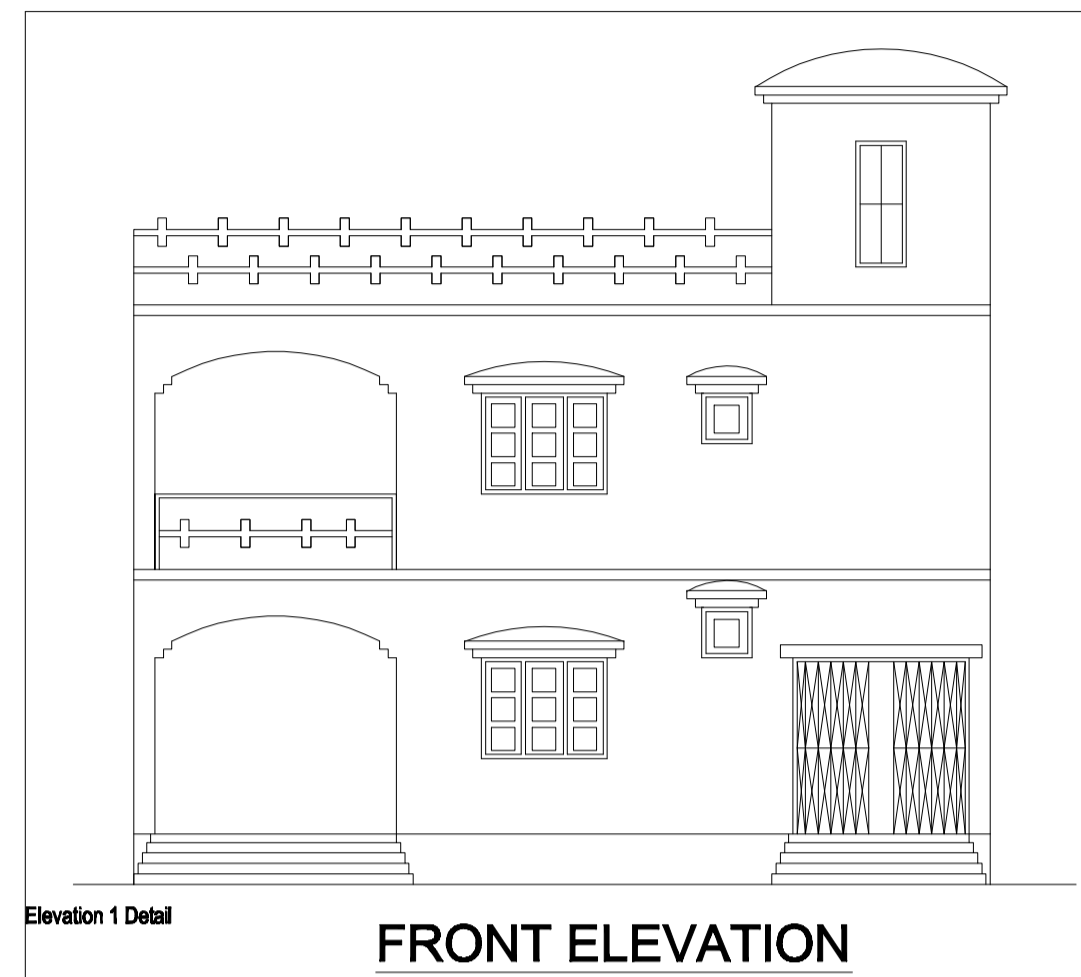

FRONT ELEVATION

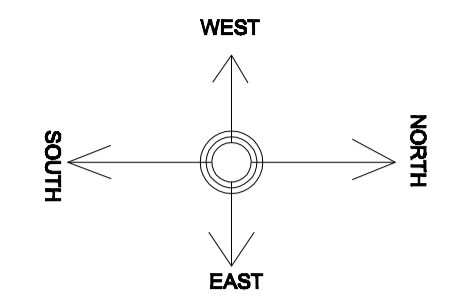
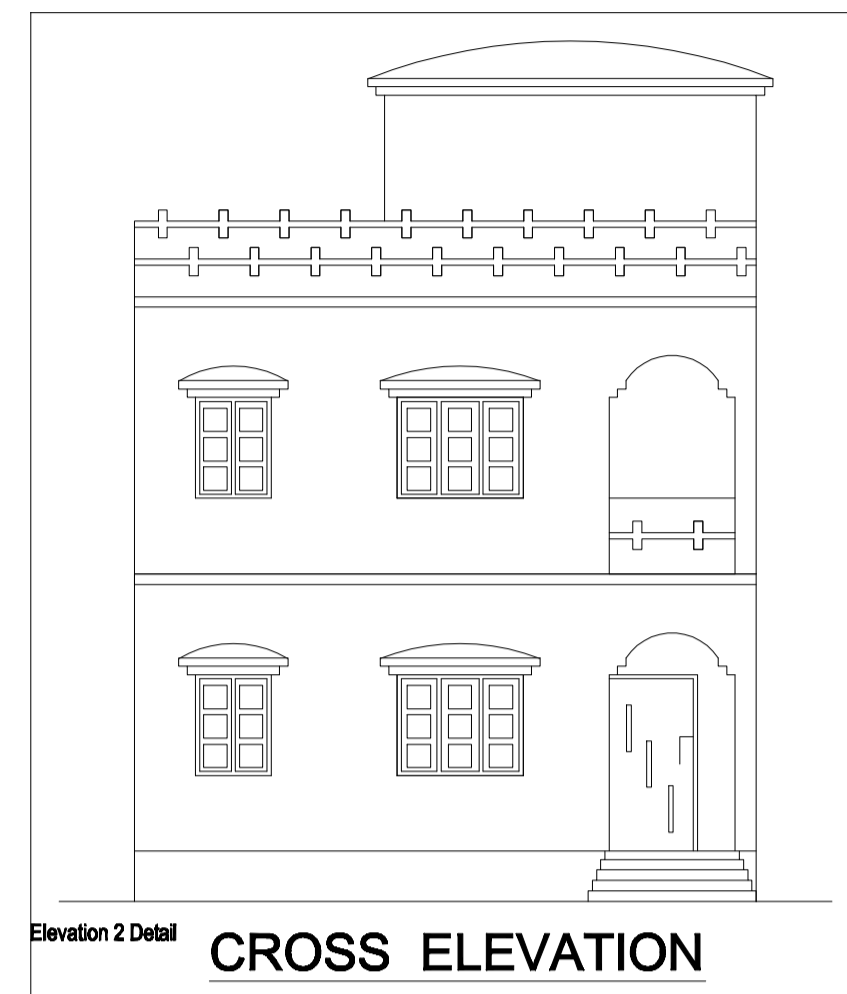

CROSS ELEVATION

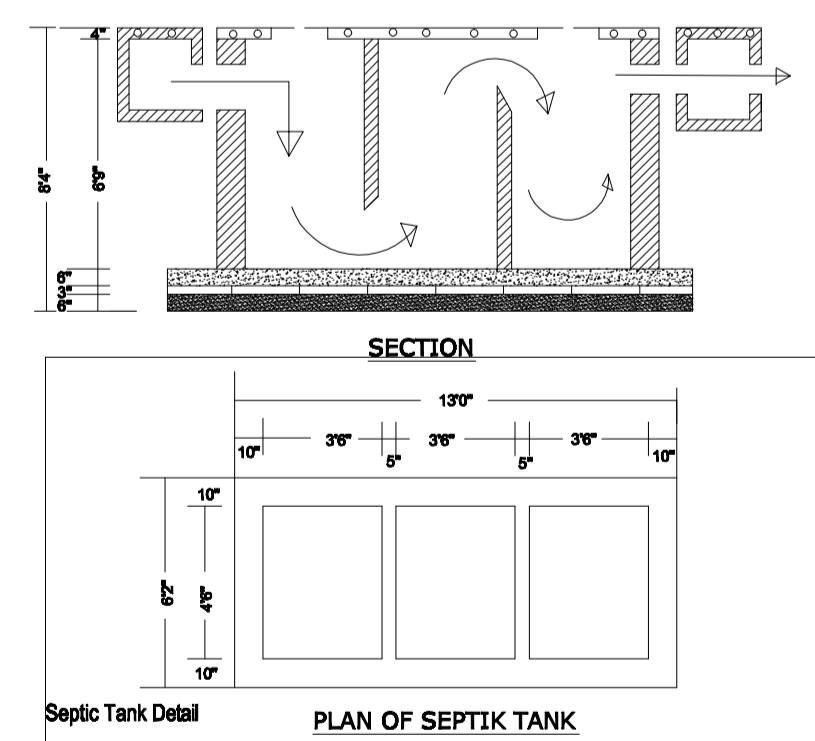
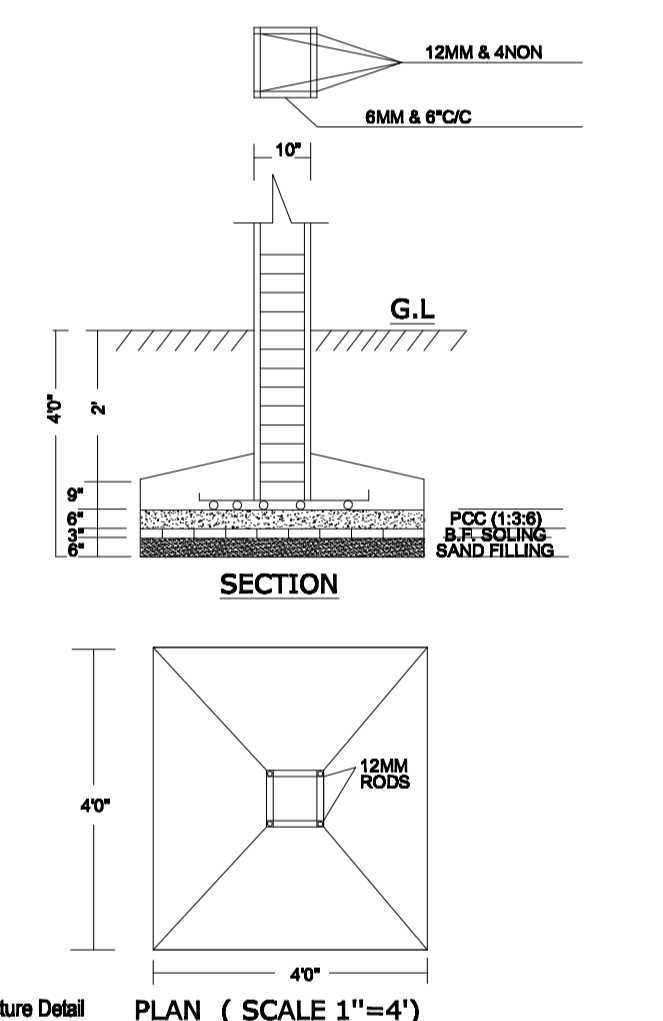
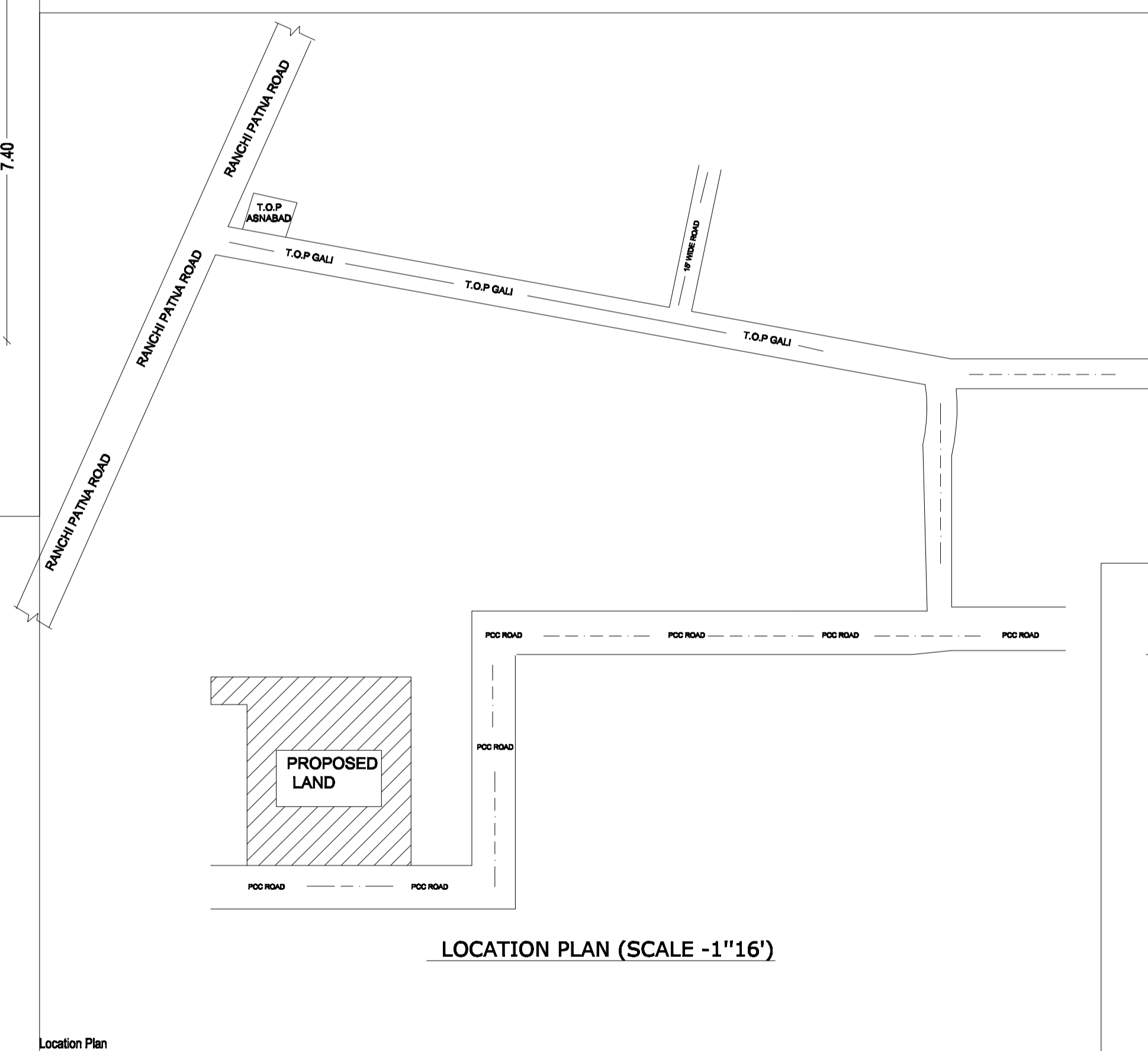
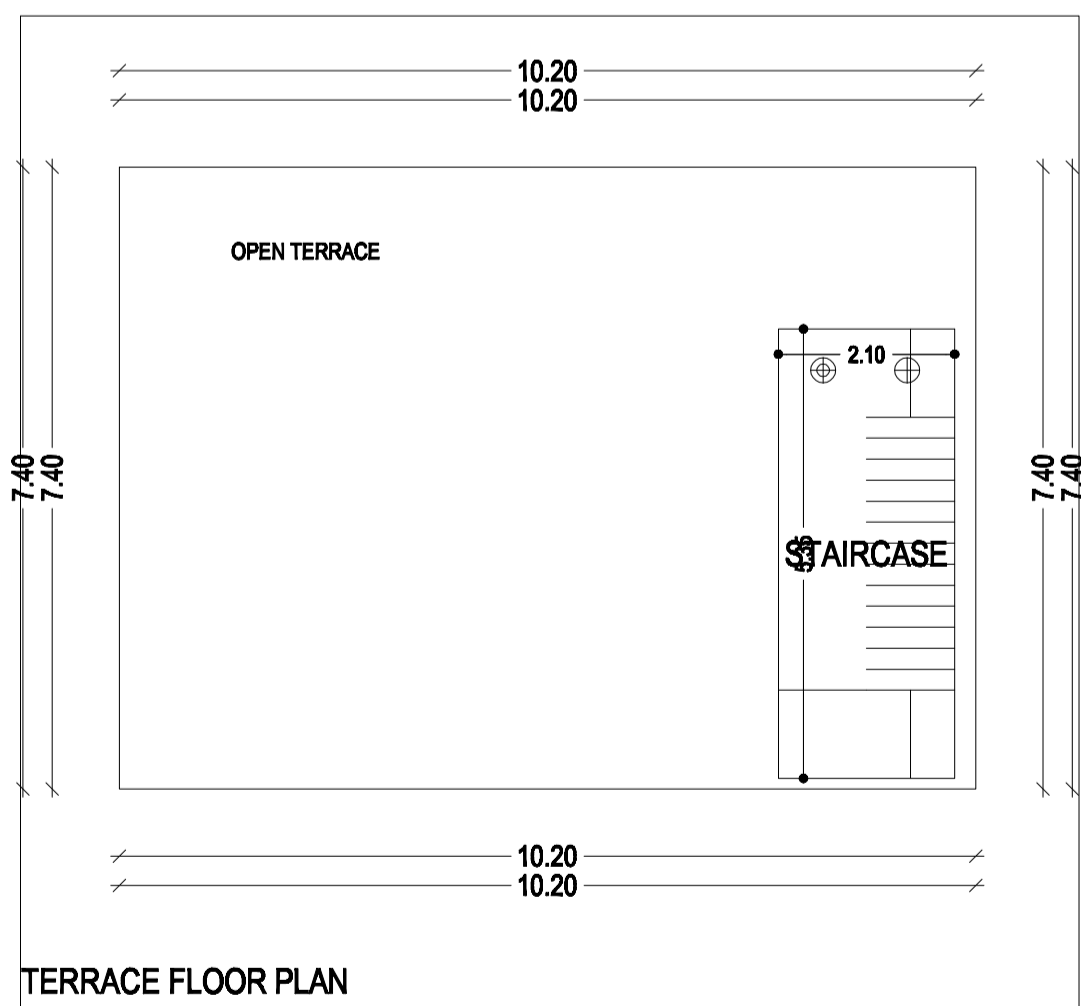
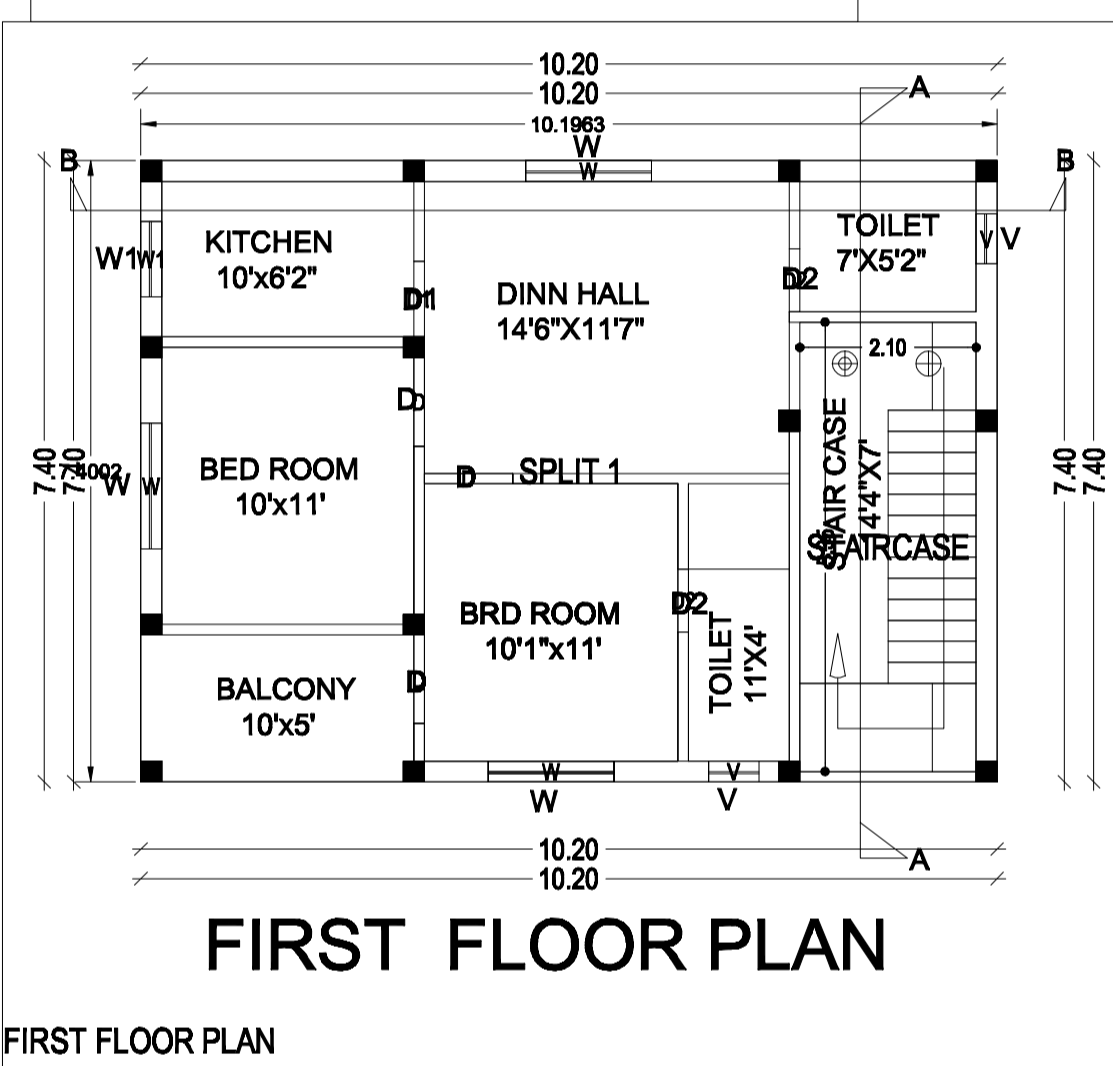
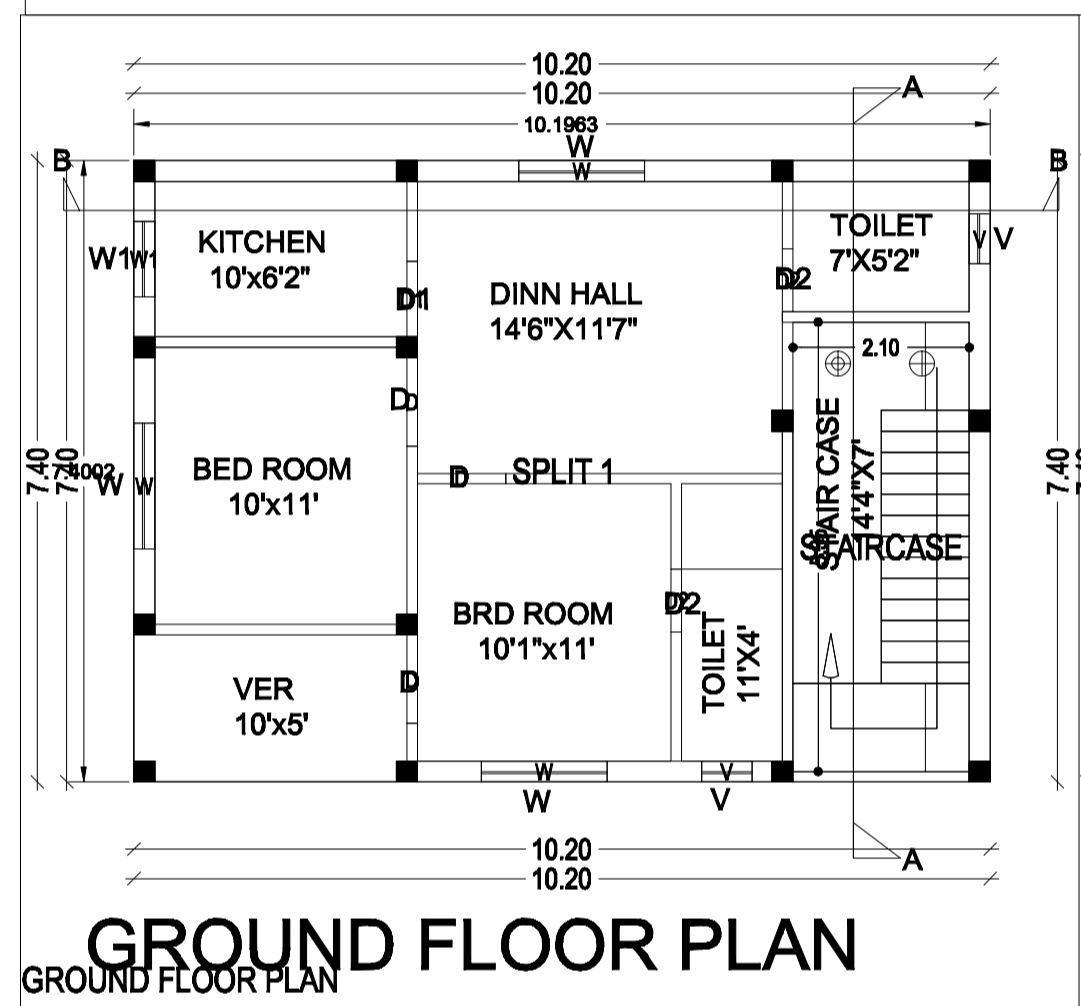
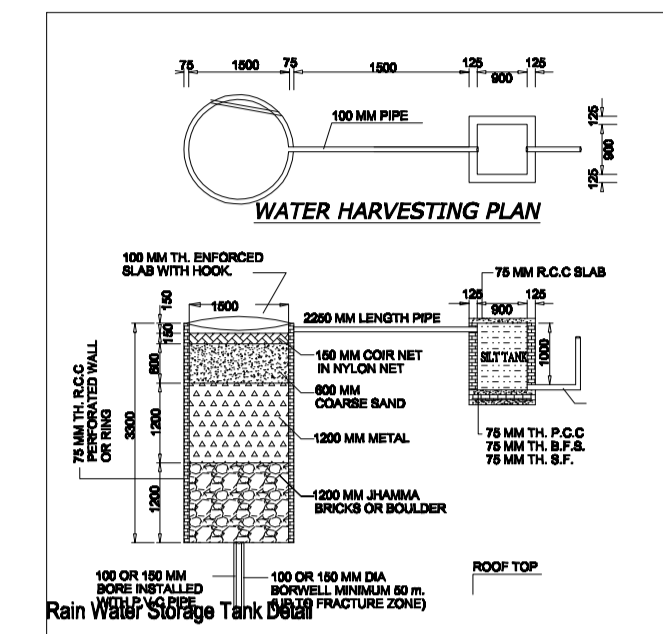
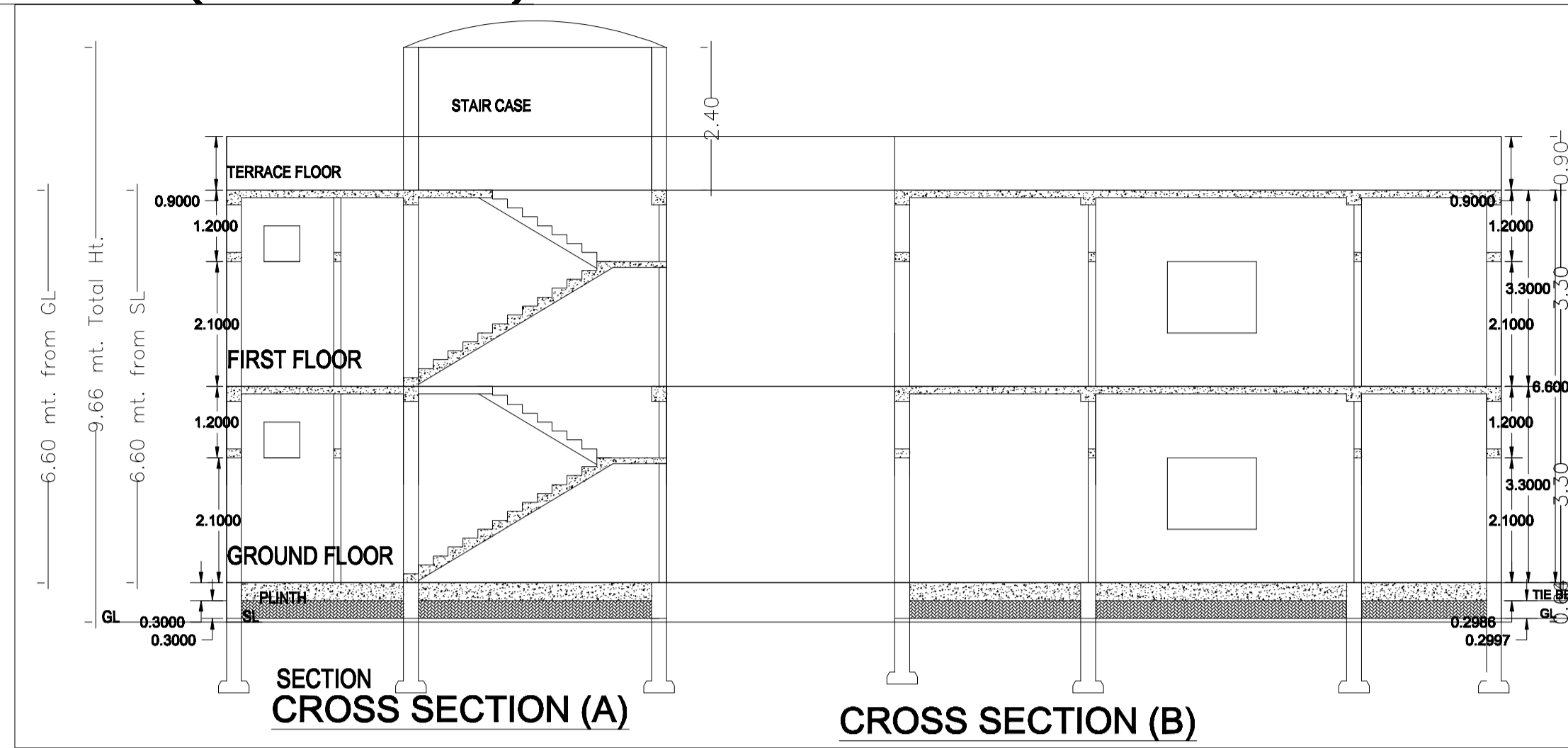

SCHEDULE OF DOORS & WINDOWS

SL.NO.	TYPE	DESCRIPTION	WIDTH	HEIGHT
01.	D	DOOR	3'6"	7'0"
02.	D1	DOOR	3'	7'0"
03.	D2	DOOR	2'6"	7'0"
04.	W	WINDOW	4'	5'0"
05.	W1	WINDOW	3'	5'
A (RESIDENTIAL)		VENTILETION	2'	2'

BOUNDARY OF THE PLOT

NORTH - KATCHA RASTA 15 FEET WIDE
 SOUTH -NIJ VENDOR
 EAST- PLOT NO- 1346, 1344
 WEST - KATCH RASTA

AREA STATEMENT (IN sq.Ft):

T OTAL AREA OF LAND = 3.75 DEC.
 COVERD AREA OF GROUND FLOOR = 838.39 SQ.FT.
 COVERD AREA OF FIRST FLOOR = 838.39 SQ.FT.
TOTAL COVERD AREA = 1676.78 SQ.FT.
155.83 SQ.MT.

SIGNATURE OF OWNERS

SIGNATURE OF ARCHITECT