

GROUND FLOOR SITE PLAN

SITE PLAN

FAR & Tenement Details (Table 4c-1)

Building	No. of Same Bldg	Total Built Up Area (Sq.mt.)	Proposed FAR Area (Sq.mt.) Resi.	Total FAR Area (Sq.mt.)	Total Consumed Additional FAR Area (Sq.mt.)	Tnmt (No.)
A (RESIDENTIAL)	1	190.76	190.76	190.76	190.76	01
Grand Total :		190.76	190.76	190.76	190.76	01

Proposal Basic Information

Proposal File No.	JNP/BP/0076/W01/2018
Owner Name	RENU KUMARI PRIYANKA
Khata No	02
Plot No	35
Village Name	Bishunpur
Use	Residential
SubUse	Other Residential Building

AREA STATEMENT	VERSION NO. : 1.0.33
JHUMRITILAIYA NAGAR PARISHAD	VERSION DATE: 27/02/2019
PROJECT DETAIL:	
Region: JHARKHAND URBAN LOCAL BODIES	Plot Use: Residential
District: KODERMA	Plot SubUse: Other Residential Building
Authority: JHUMRITILAIYA NAGAR PARISHAD	PlotNearbyReligiousStructure: NA
Inward No: JNP/BP/0076/W01/2018	Plot/SubPlot No: 35
Application Type: General Proposal	North: Road Width - 4.88
Project Type: Building Permission	South: Plot No. - LAND OF KRISHNA KUMAR & VIJAY KUMAR
Nature of Development: New	East: Plot No. - LAND OF SMT MANJU DEVI
Location of Development Area: Old Area	West: Road Width - 5.48
AREA DETAILS:	
AREA OF PLOT (Minimum)	(A) 324.00
NET AREA OF PLOT(Gross Plot Area - Deduction from Gross Plot area)	(A-Deductions) 324.00
Deduction for Balance Plot Area(from Gross Plot Area)	
Common Plot	33.79
Total	33.79
BALANCE AREA OF PLOT(Net Plot Area - Recreational/Amenity space)	(A-Deductions) 290.21
PLOT AREA FOR COVERAGE(Net Plot Area)	(A-Deductions) 324.00
Plot Area for FAR (Net Plot Area + RoadWidening Area)	(A-Deductions) 324.00
COVERAGE CHECK	
Permissible Coverage area (60.00 %)	194.40
Proposed Coverage Area (58.88 %)	190.77
Total Prop. Coverage Area (58.88 %)	190.77
Balance coverage area (1.12 %)	3.63
FAR CHECK	
Perm. FAR Area (1.80)	583.20
Total Perm. FAR area	583.20
Residential FAR	190.76
Proposed FAR Area	190.76
Total Proposed FAR Area	190.76
Consumed FAR (Factor)	0.59
Balance FAR Area	392.44
BUILT UP AREA CHECK	
Total Proposed BuiltUp Area	190.76
ARCHITECT (Regd)	RAJIB KUMAR SAHA
ENGINEER (Regd)	
SUPERVISOR (Regd)	
OWNER (Regd)	RENU KUMARI PRIYANKA
DEVELOPMENT AUTHORITY	LOCAL BODY

COLOR INDEX	
PLOT BOUNDARY	Black
ABUTTING ROAD	Green
PROPOSED CONSTRUCTION	Red
COMMON PLOT	Yellow
ROAD WIDENING AREA	Light Yellow
EXISTING (To be retained)	Blue
EXISTING (To be demolished)	Light Blue

Buildingwise Floor FAR Details

Floor Name	Building Name A (RESIDENTIAL)		Total	
	Proposed Built Up Area (Sq.mt.)	Proposed FAR Area (Sq.mt.)	Total Proposed Built Up Area (Sq.mt.)	Total FAR Area (Sq.mt.)
Ground Floor	190.76	190.76	190.76	190.76
Terrace Floor	0.00	0.00	0.00	0.00
Total :	190.76	190.76	190.76	190.76

Building USE/SUBUSE Details

Building Name	Building Use	Building SubUse	Building Structure
A (RESIDENTIAL)	Residential	Bungalow/ Dwelling / Non Apartment	Non-Highrise

LTP NAME AND SIGNATURE	STRUCTURAL ENG'S NAME AND SIGNATURE	BUILDER NAME AND SIGNATURE	DIGITAL SIGNATURE
RAJIB KUMAR SAHA JNP/ARC/0004/2017			

Proposal Basic Information	
Proposal File No.	JNP/IBP/0076/W01/2018
Owner Name	RENU KUMARI PRIYANKA
Khata No	02
Plot No	35
Village Name	Bishunpur
Use	Residential
SubUse	Other Residential Building

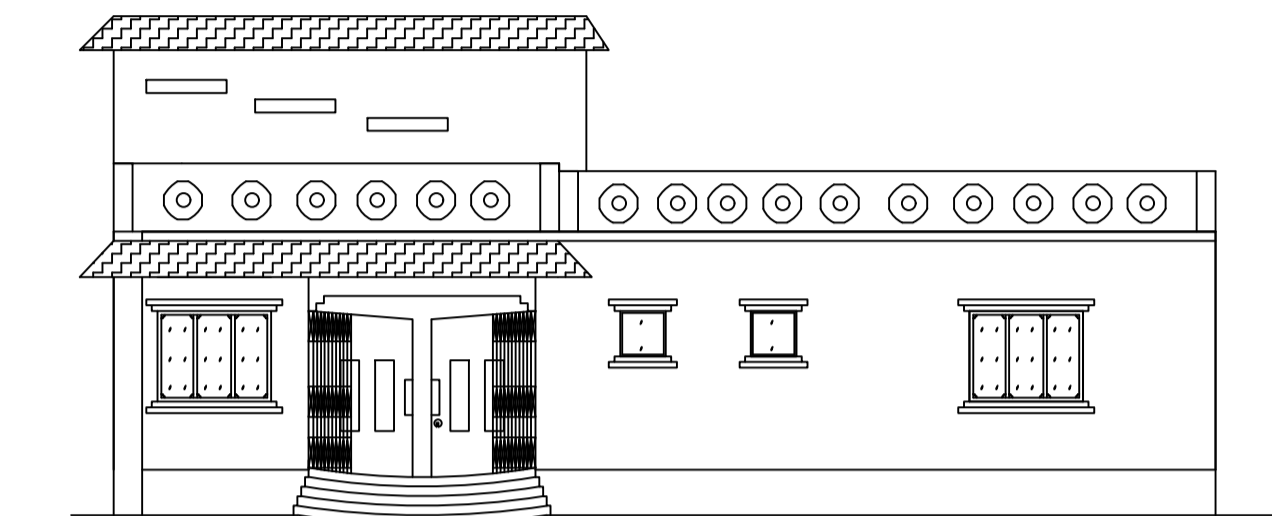
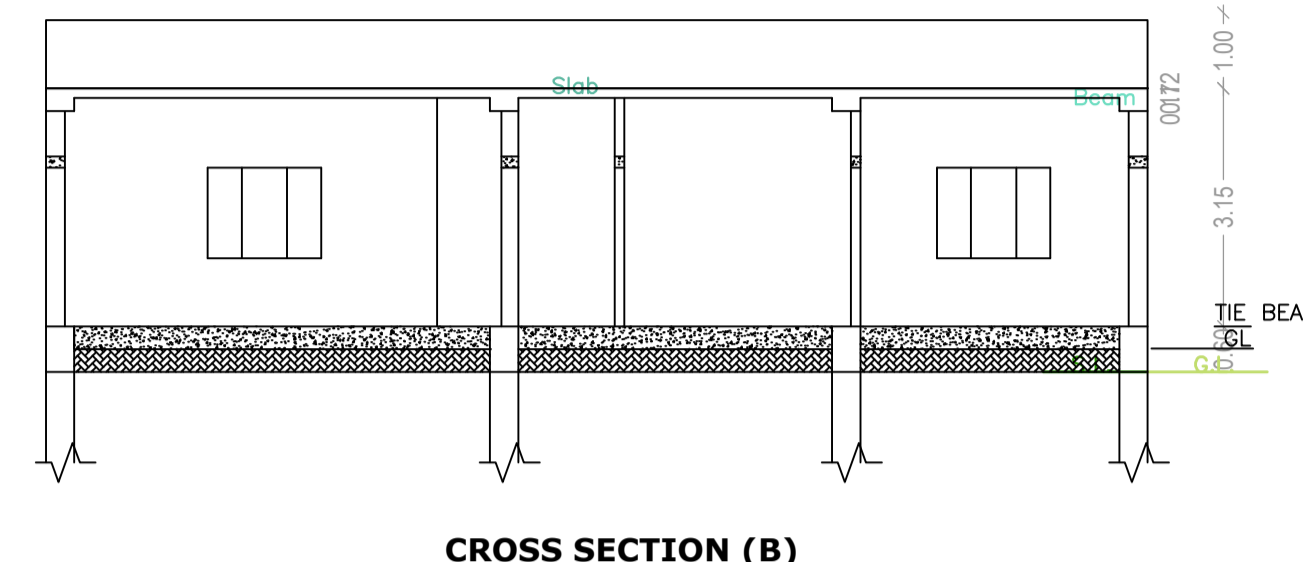
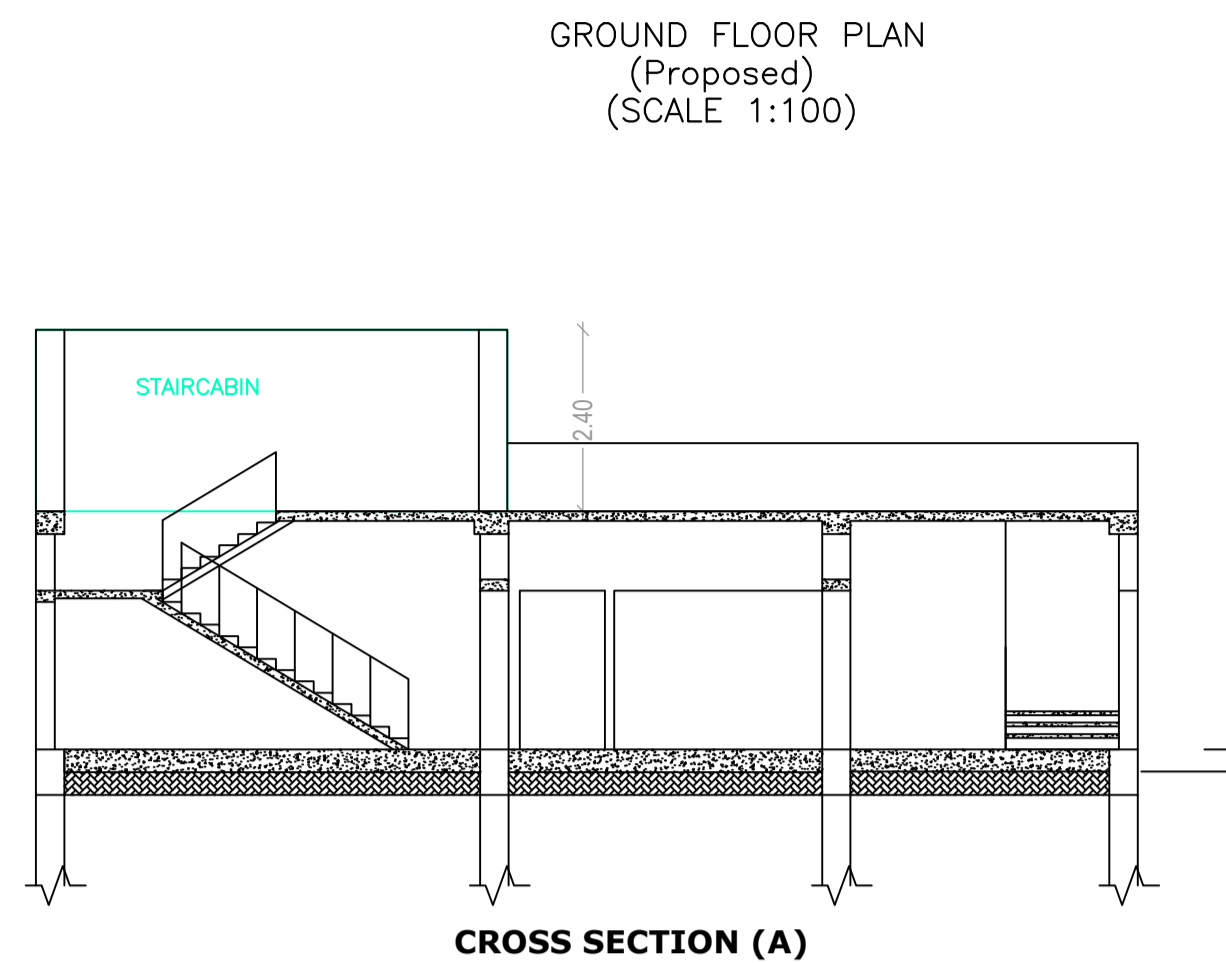
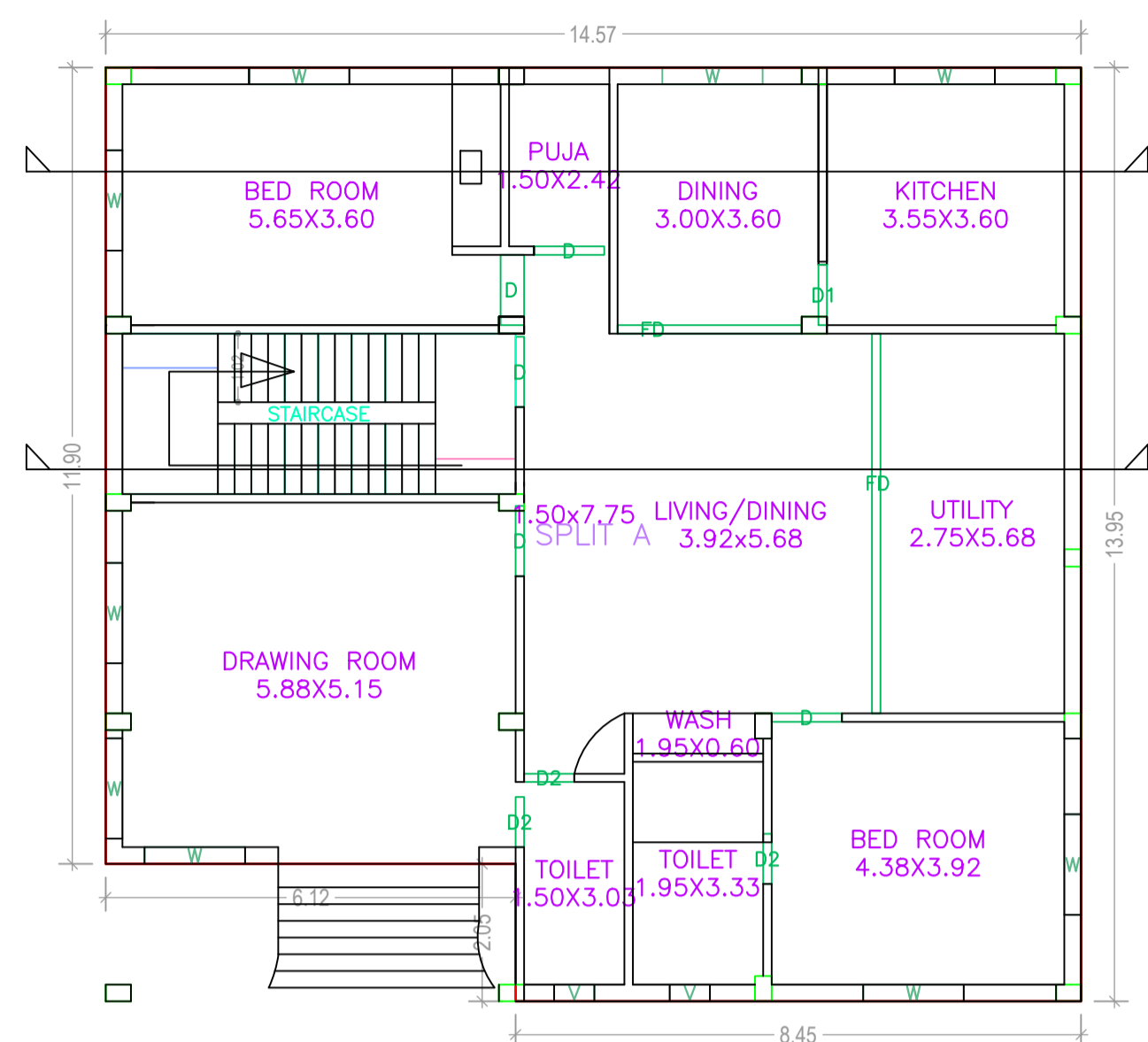

FRONT ELEVATION

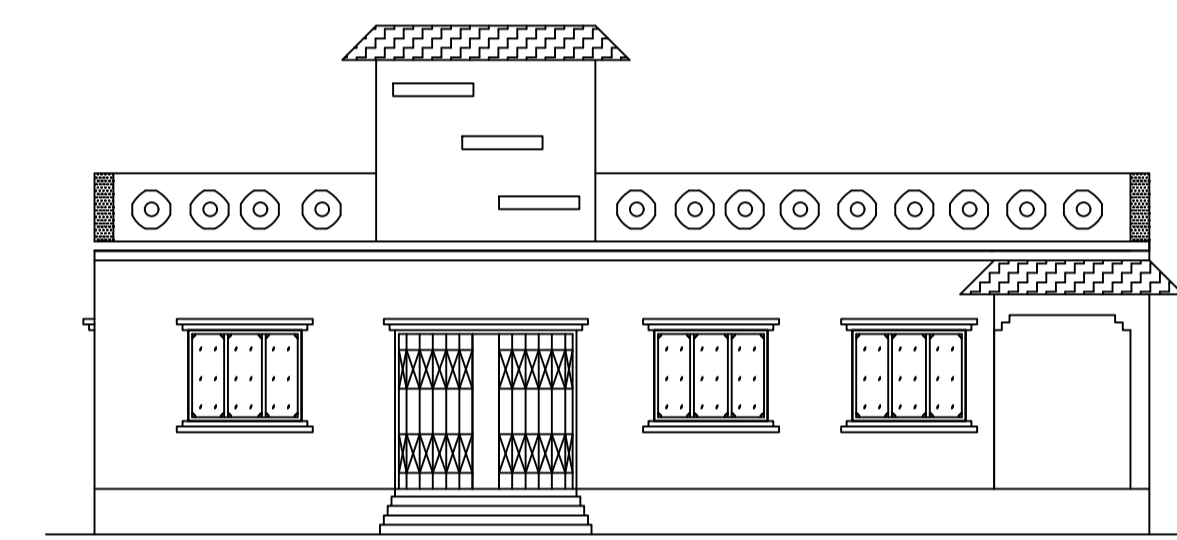

CROSS ELEVATION

GROUND FLOOR PLAN (Proposed) (SCALE 1:100)

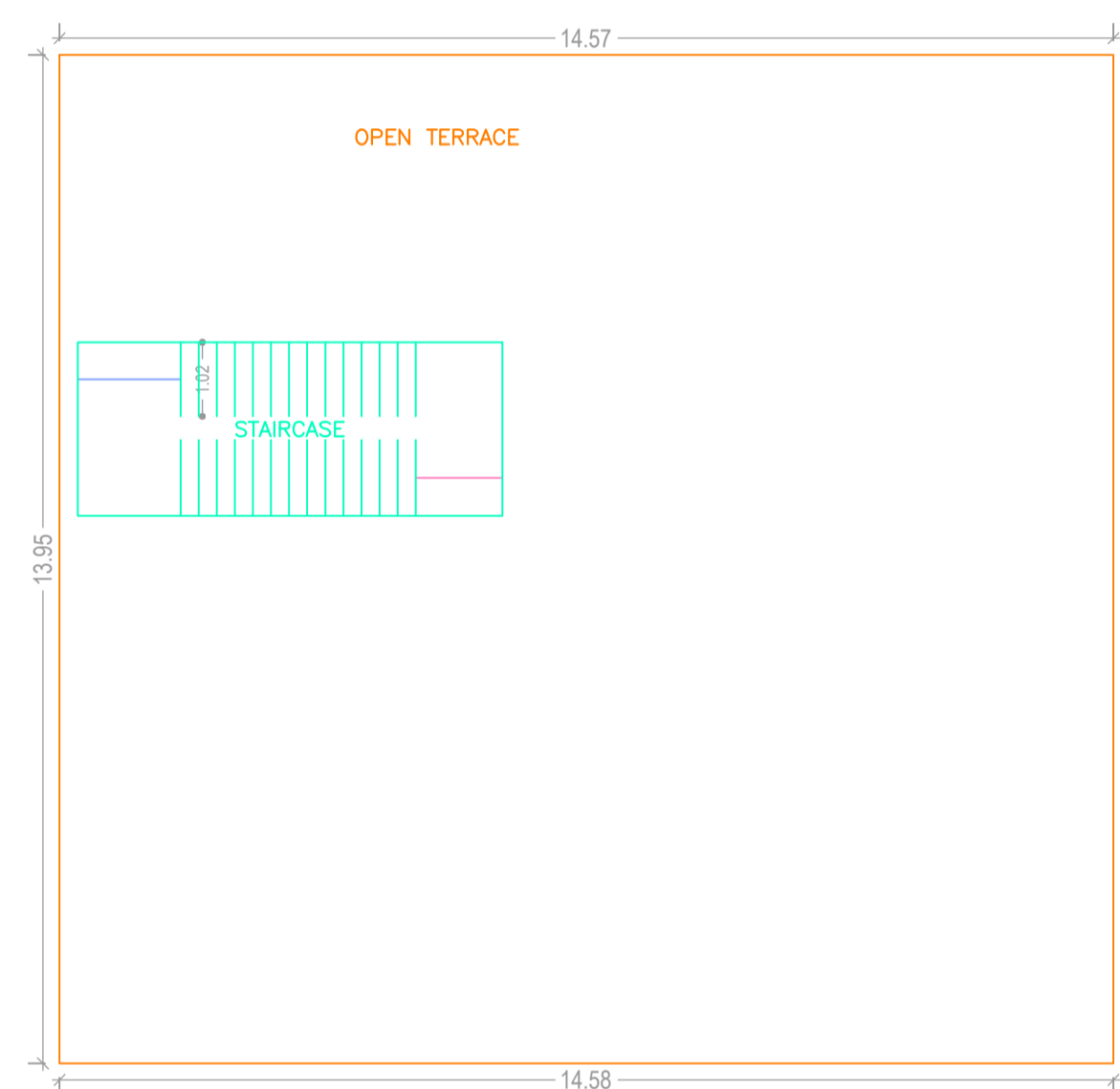

TERRACE FLOOR PLAN (SCALE 1:100)

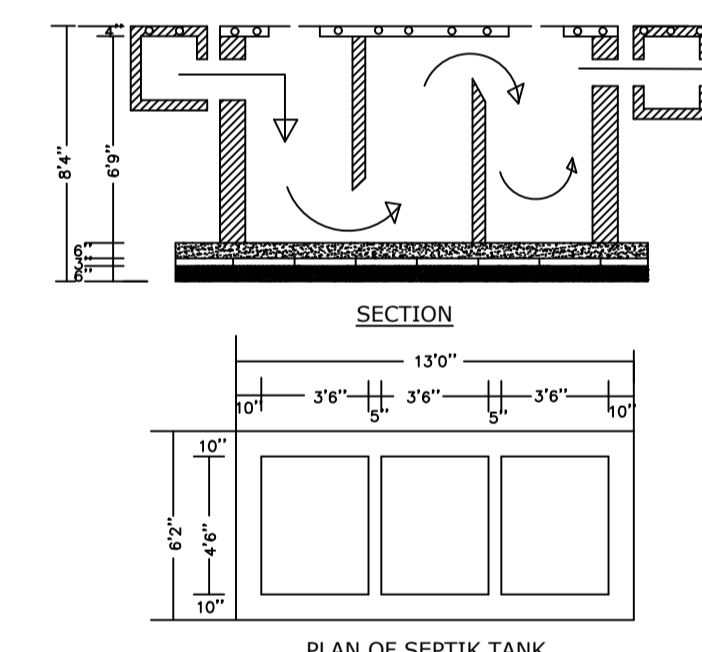

PLAN OF SEPTIC TANK

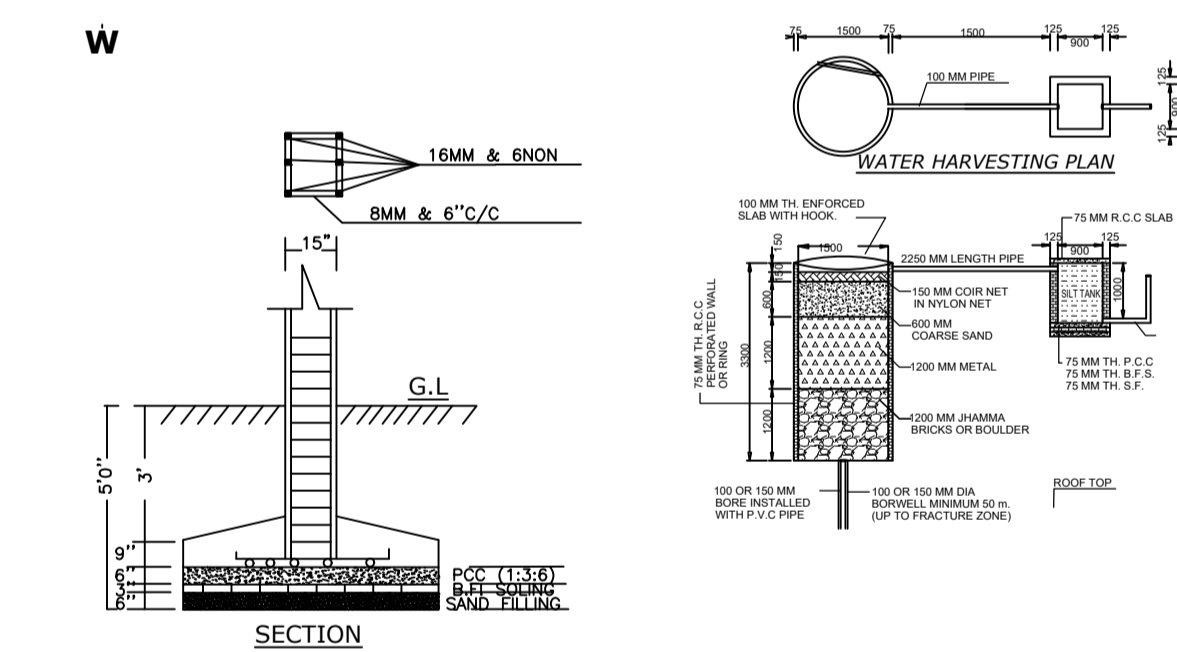

SECTION

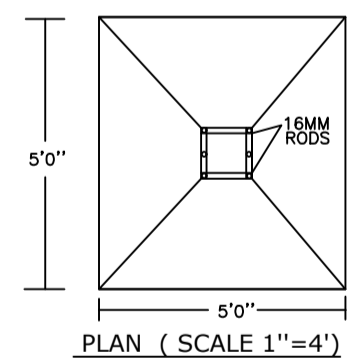

PLAN (SCALE 1"=4')

Building :A (RESIDENTIAL)					
Floor Name	Total Built Up Area (Sq.mt.)	Proposed FAR Area (Sq.mt.)	Total FAR Area (Sq.mt.)	Total Consumed Additional FAR Area (Sq.mt.)	Tnmt (No.)
Ground Floor	190.76	190.76	190.76	190.76	01
Terrace Floor	0.00	0.00	0.00	0.00	00
Total :	190.76	190.76	190.76	190.76	01
Total Number of Same Buildings	1				
	190.76	190.76	190.76	190.76	01

SCHEDULE OF DOOR:

BUILDING NAME	NAME	LENGTH	HEIGHT	NOS
A (RESIDENTIAL)	D2	0.75	2.10	03
A (RESIDENTIAL)	D1		2.10	01
A (RESIDENTIAL)	D	1.05	2.10	
A (RESIDENTIAL)	FD	2.75	2.10	01
		5.68	2.10	01

SCHEDULE OF WINDOW/VENTILATION:

BUILDING NAME	NAME	LENGTH	HEIGHT	NOS
A (RESIDENTIAL)	V	0.60	0.90	02
A (RESIDENTIAL)	W	1.50	1.20	09

UnitBUA Table for Building :A (RESIDENTIAL)

FLOOR	Name	UnitBUA Type	UnitBUA Area	Carpet Area	No. of Rooms	No. of Tenement
GROUND FLOOR PLAN	SPLIT A	FLAT	162.17	161.84	11	1
Total:	-	-	162.17	161.84	11	1

LTP NAME AND SIGNATURE	STRUCTURAL ENG'S NAME AND SIGNATURE	BUILDER NAME AND SIGNATURE	DIGITAL SIGNATURE
RAJIB KUMAR SAHA JNP/ARC/0004/2017			