

FRONT ELEVATION

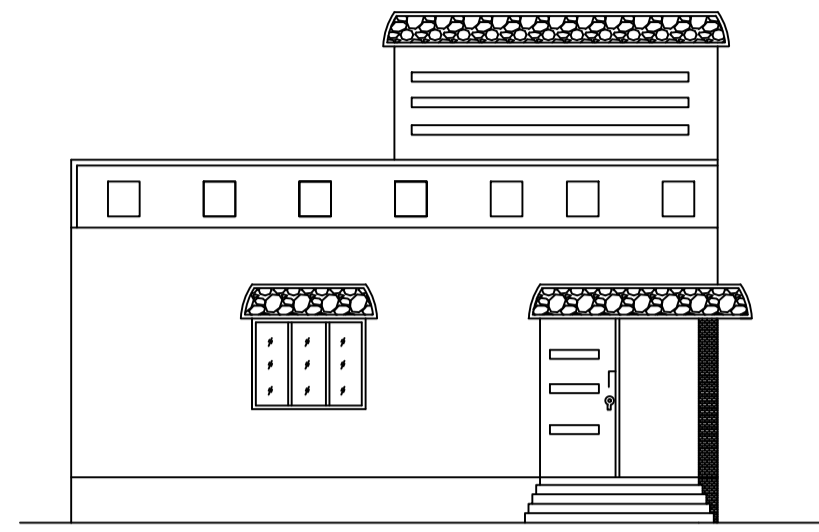

CROSS ELEVATION

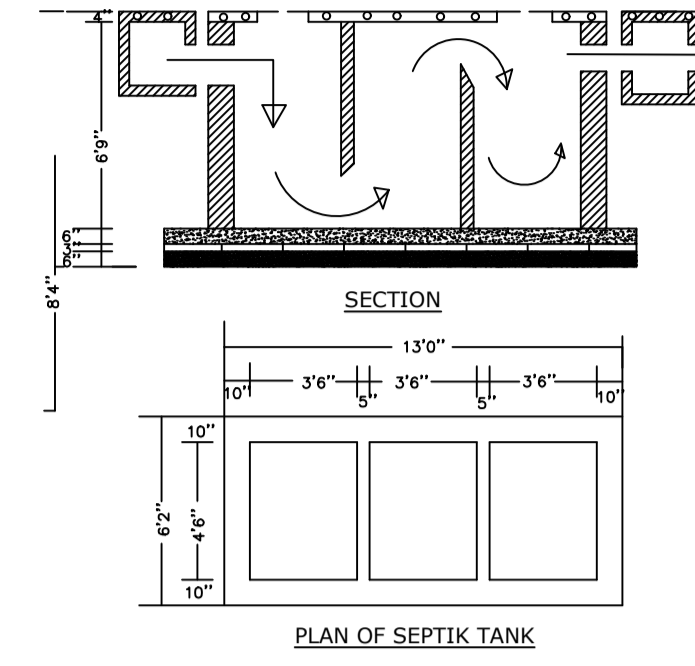
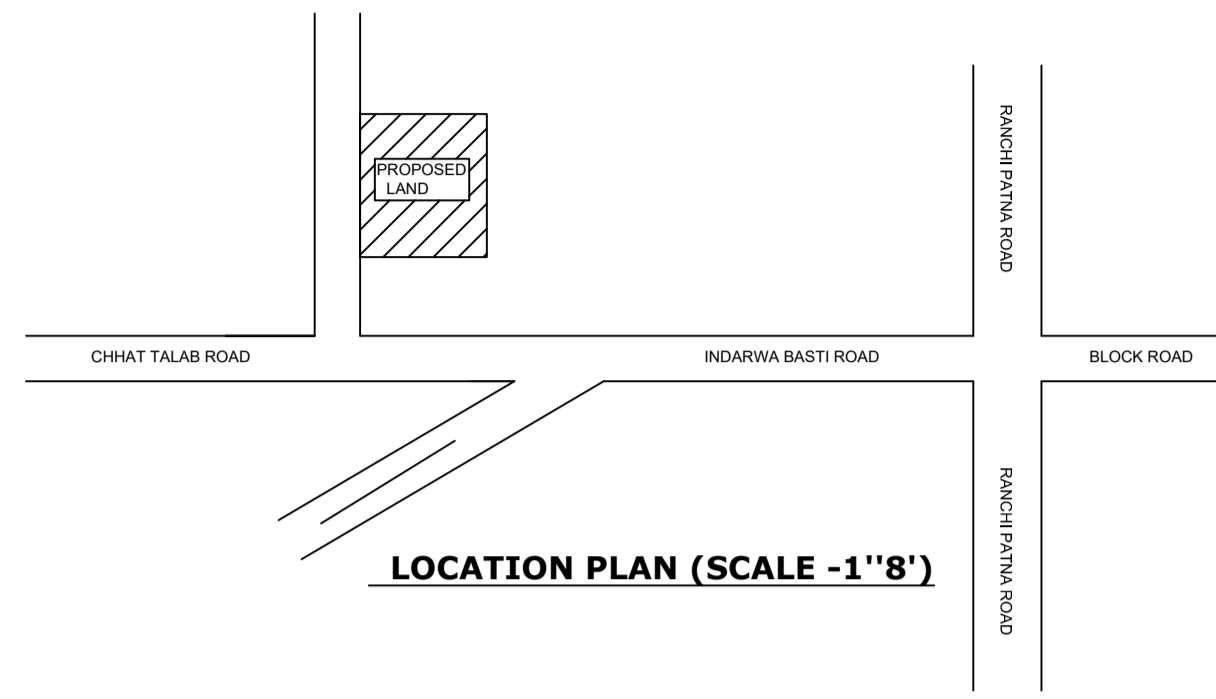

Proposal Basic Information

Proposal File No.	JNP/BP/0079/W05/2018
Owner Name	ANIL YADAV
Khata No	07
Plot No	1880
Village Name	Asana
Use	Residential
Other Residential Building	

Floor Name	Total Built Up Area (Sq.mt.)	Proposed FAR Area (Sq.mt.)	Total FAR Area (Sq.mt.)	Total Consumed Additional FAR Area (Sq.mt.)	Tnmt (No.)
Ground Floor	95.63	95.63	95.63	95.63	01
Terrace Floor	0.00	0.00	0.00	0.00	00
Total	95.63	95.63	95.63	95.63	01
Total Number of Same Buildings	1				
Total	95.63	95.63	95.63	95.63	01

Buildingwise Floor FAR Details

Floor Name	Building Name		Total	
	Proposed Built Up Area (Sq.mt.)	Proposed FAR Area (Sq.mt.)	Total Proposed Built Up Area (Sq.mt.)	Total FAR Area (Sq.mt.)
Ground Floor	95.63	95.63	95.63	95.63
Terrace Floor	0.00	0.00	0.00	0.00
Total	95.63	95.63	95.63	95.63

FAR & Tenement Details (Table 4c-1)

Building	No. of Same Bldg	Total Built Up Area (Sq.mt.)	Proposed FAR Area (Sq.mt.)	Total FAR Area (Sq.mt.)	Total Consumed Additional FAR Area (Sq.mt.)	Tnmt (No.)
A (RESIDENTIAL)	1	95.63	95.63	95.63	95.63	01
Grand Total	1	95.63	95.63	95.63	95.63	01

SCHEDULE OF DOOR:

BUILDING NAME	NAME	LENGTH	HEIGHT	NOS
A (RESIDENTIAL)	D2	0.75	2.10	02
A (RESIDENTIAL)	D1	0.90	2.10	01
A (RESIDENTIAL)	D	1.05	2.10	03
A (RESIDENTIAL)	D	1.17	2.10	01

SCHEDULE OF WINDOW/VENTILATION:

BUILDING NAME	NAME	LENGTH	HEIGHT	NOS
A (RESIDENTIAL)	V	0.60	0.60	02
A (RESIDENTIAL)	W1	0.90	1.20	01
A (RESIDENTIAL)	W	1.50	1.20	05

COLOR INDEX

PLOT BOUNDARY	Black
ABUTTING ROAD	Green
PROPOSED CONSTRUCTION	Red
COMMON PLOT	Yellow
ROAD WIDENING AREA	Blue
EXISTING (To be retained)	Blue
EXISTING (To be demolished)	Yellow

AREA STATEMENT	VERSION NO.: 1.0.30
JHUMRITILAIYA NAGAR PARISHAD	VERSION DATE: 30/06/2018

PROJECT DETAIL:	
Region: JHARKHAND URBAN LOCAL BODIES	Plot Use: Residential
District: KODERMA	Plot SubUse: Other Residential Building
Authority: JHUMRITILAIYA NAGAR PARISHAD	PlotNearbyReligiousStructure: NA
Inward_No: JNP/BP/0079/W05/2018	Plot/SubPlot No: 1880
Application Type: General Proposal	North: Road Width - 3.60
Project Type: Building Permission	South: Plot No. - NJJ
Nature of Development: New	East: Plot No. - PLOT OF JAGDISH YADAV
Location of Development Area: Old Area	West: Plot No. - PLOT OF JAGDISH YADAV

AREA DETAILS:		SQ.MT.
AREA OF PLOT (Minimum)	(A)	156.60
NET AREA OF PLOT (Gross Plot Area - Deduction from Gross Plot area)	(A-Deductions)	156.60

Deduction for Balance Plot Area (from Gross Plot Area)		18.35
Common Plot		18.35
BALANCE AREA OF PLOT (Net Plot Area - Recreational/Amenity space)		138.25
PLOT AREA FOR COVERAGE (Net Plot Area)		156.60
Plot Area for FAR (Net Plot Area + Road/Widening Area)		156.60

COVERAGE CHECK		
Permissible Coverage area (70.00 %)		109.62
Proposed Coverage Area (61.07 %)		95.63
Total Prop. Coverage Area (61.07 %)		95.63
Balance coverage area (8.93 %)		13.99

FAR CHECK		
Perm. FAR Area (1.50)		234.90
Total Perm. FAR area		234.90
Residential FAR		95.63
Proposed FAR Area		95.63
Total Proposed FAR Area		95.63
Consumed FAR (Factor)		0.61
Balance FAR Area		139.27

BUILT UP AREA CHECK		
Total Proposed BuiltUp Area		95.63
ARCHITECT (Regd)	RAJIB KUMAR SAHA	
ENGINEER (Regd)		
SUPERVISOR (Regd)		
OWNER (Regd)	ANIL YADAV	
DEVELOPMENT AUTHORITY		LOCAL BODY

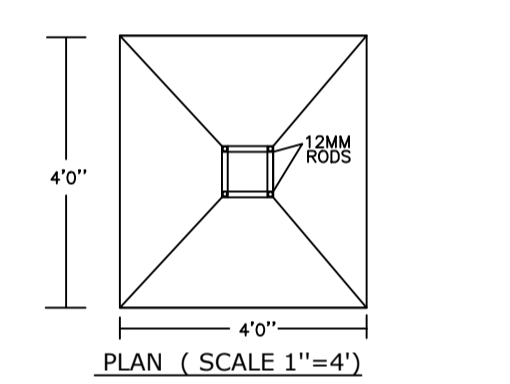
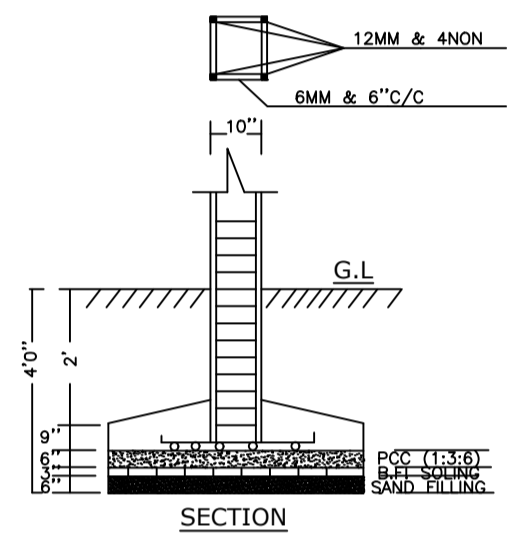
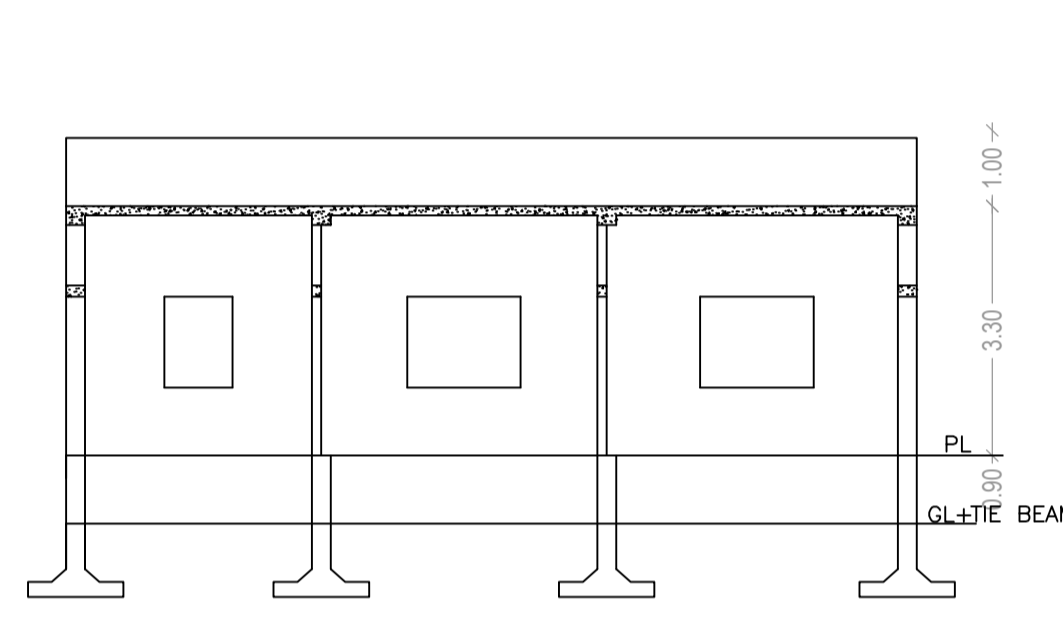
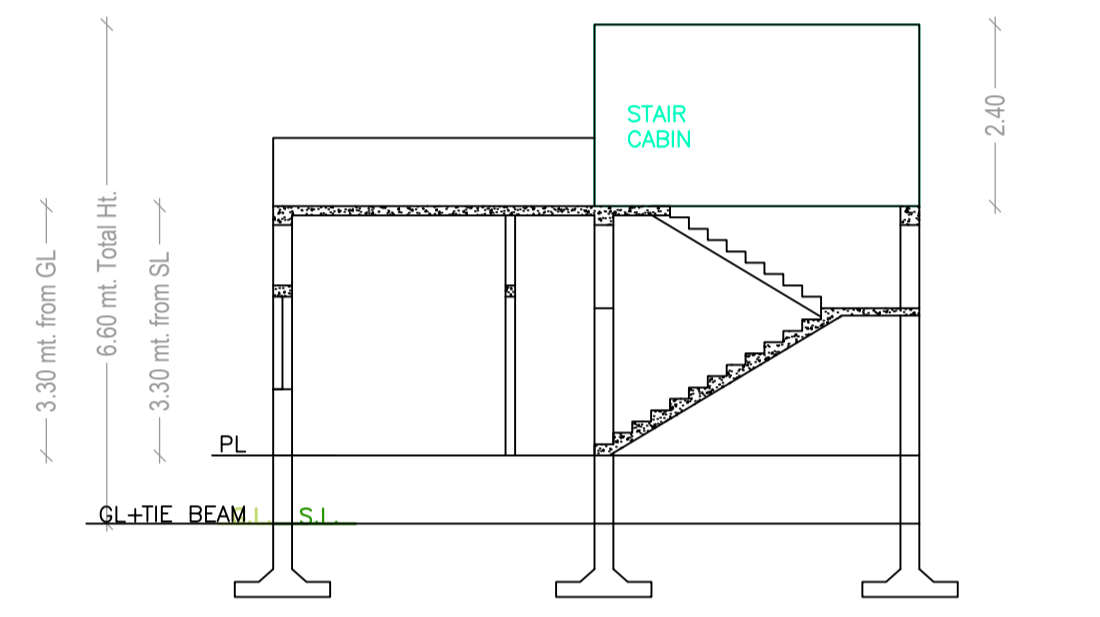

UnitBUA Table for Building :A (RESIDENTIAL)

FLOOR	Name	UnitBUA Type	UnitBUA Area	Carpet Area	No. of Rooms	No. of Tenement
GROUND FLOOR PLAN	SPLIT 1	FLAT	76.09	75.70	8	1
Total	-	-	76.09	75.70	8	1

Building USE/SUBUSE Details

Building Name	Building Use	Building SubUse	Building Structure
A (RESIDENTIAL)	Residential	Bungalow Dwelling / Non Apartment	Non-Highrise

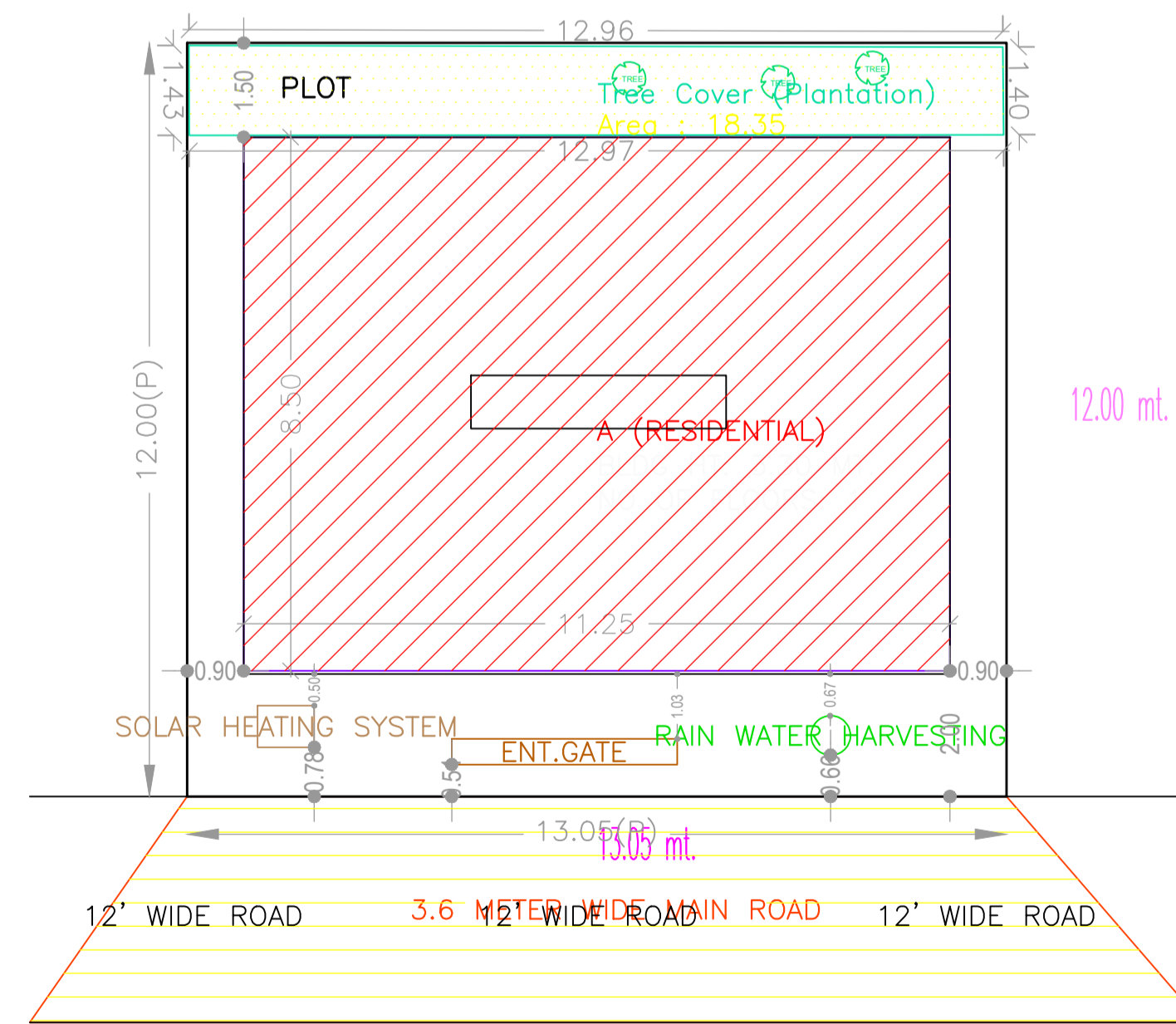
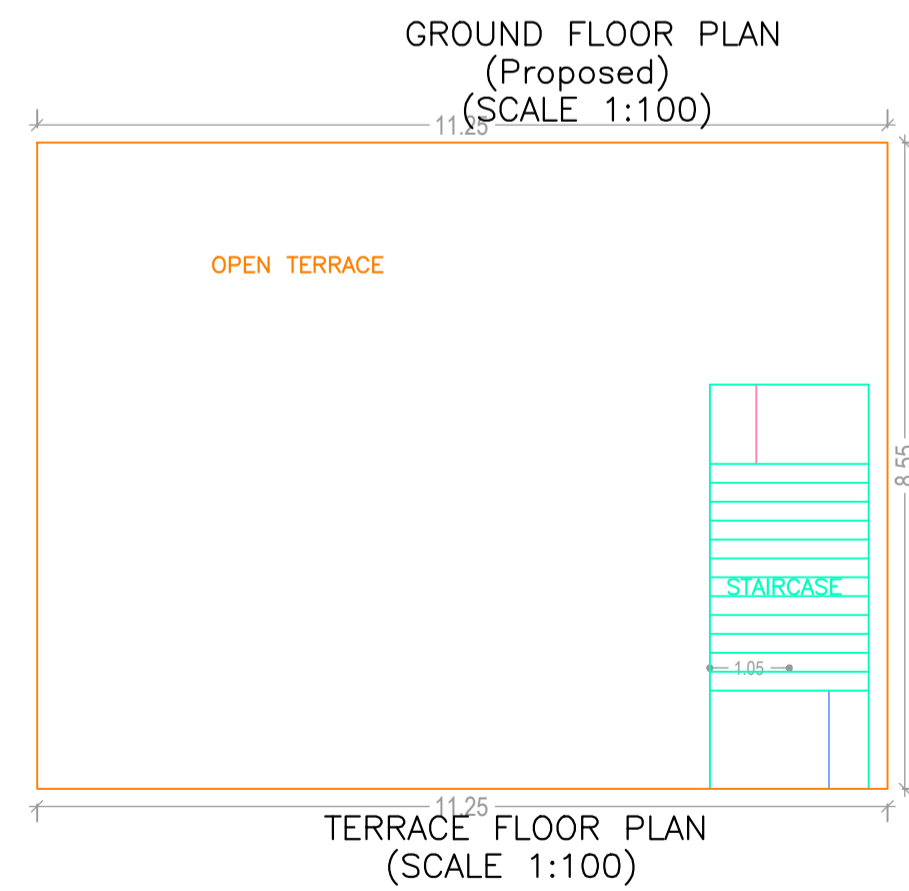
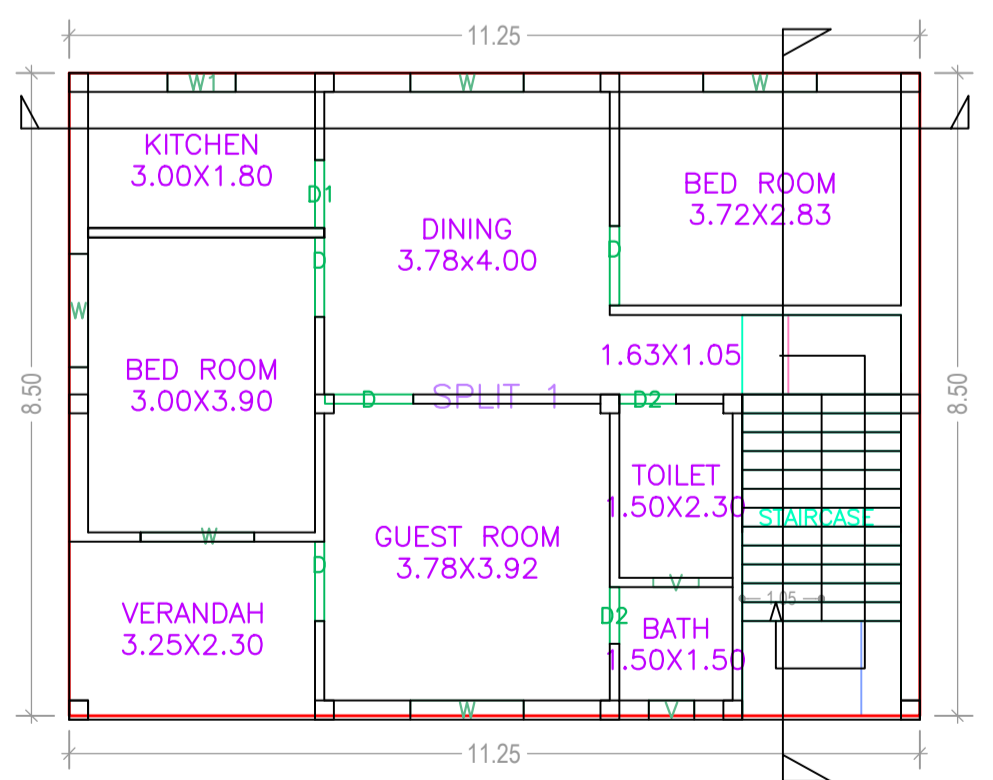
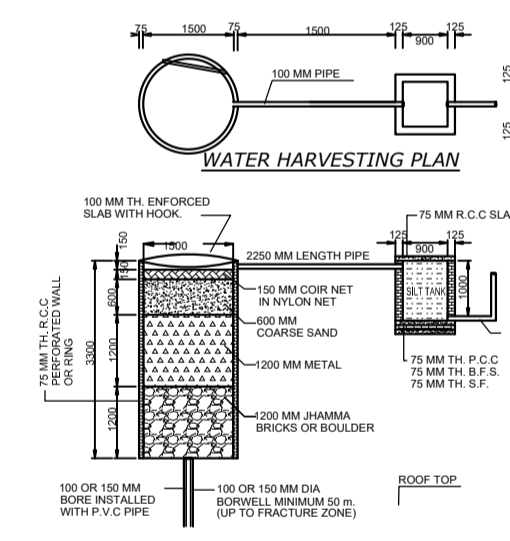

LTP NAME AND SIGNATURE	STRUCTURAL ENG'S NAME AND SIGNATURE	BUILDER NAME AND SIGNATURE	DIGITAL SIGNATURE
RAJIB KUMAR SAHA JNP/ARC/0004/2017			