

Building -AAA (RITESH DUGAR MUKESH DUGAR)

Floor Name	Total Built Up Area (Sq.mt.)	Proposed FAR Area (Sq.mt.)	Total FAR Area (Sq.mt.)	Total Consumed Additional FAR Area (Sq.mt.)	Tnmt (No.)
Basement Floor	21.39	21.39	21.39	21.39	01
Ground Floor	21.39	21.39	21.39	21.39	00
First Floor	21.39	21.39	21.39	21.39	00
Terrace Floor	0.00	0.00	0.00	0.00	00
Total :	64.17	64.17	64.17	64.17	01
Total Number of Same Buildings	1				
Total :	64.17	64.17	64.17	64.17	01

SCHEDULE OF DOOR:

BUILDING NAME	NAME	LENGTH	HEIGHT	NOS
AAA (RITESH DUGAR MUKESH DUGAR)	D2	0.75	2.10	01
AAA (RITESH DUGAR MUKESH DUGAR)	D	1.00	2.13	03

SCHEDULE OF WINDOW/VENTILATION:

BUILDING NAME	NAME	LENGTH	HEIGHT	NOS
AAA (RITESH DUGAR MUKESH DUGAR)	V	0.60	0.60	01
AAA (RITESH DUGAR MUKESH DUGAR)	W1	1.50	1.20	02
AAA (RITESH DUGAR MUKESH DUGAR)	W	2.00	1.20	01

UnitBUA Table for Building -AAA (RITESH DUGAR MUKESH DUGAR)

FLOOR	Name	UnitBUA Type	UnitBUA Area	Carpet Area	No. of Rooms	No. of Tenement
BASEMENT FLOOR PLAN	SPLIT flat a	FLAT	34.70	33.46	1	1
GROUND FLOOR PLAN	SPLIT flat a	FLAT	0.00	0.00	3	0
FIRST FLOOR PLAN	SPLIT flat a	FLAT	0.00	0.00	1	0
Total:	-	-	34.70	33.46	5	1

FAR & Tenement Details (Table 4c-1)

Building	No. of Same Bldg	Total Built Up Area (Sq.mt.)	Proposed FAR Area (Sq.mt.)	Total FAR Area (Sq.mt.)	Total Consumed Additional FAR Area (Sq.mt.)	Tnmt (No.)
AAA (RITESH DUGAR MUKESH DUGAR)	1	64.17	64.17	64.17	64.17	01
Grand Total :	1	64.17	64.17	64.17	64.17	01

Proposal Basic Information

Proposal File No.	JNP/IBP/0019/W11/2019
Owner Name	1. RITESH KUMAR DUGAR 2. MUKESH KUMAR DUGAR
Khata No	802
Plot No	7398/7941
Village Name	Tilaiya
Use	Residential
SubUse	Bungalow/ Dwelling / Non Apartment

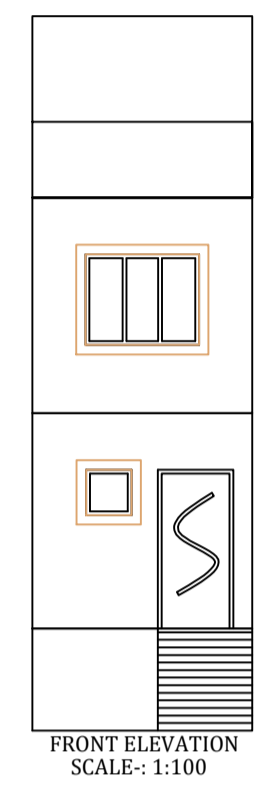
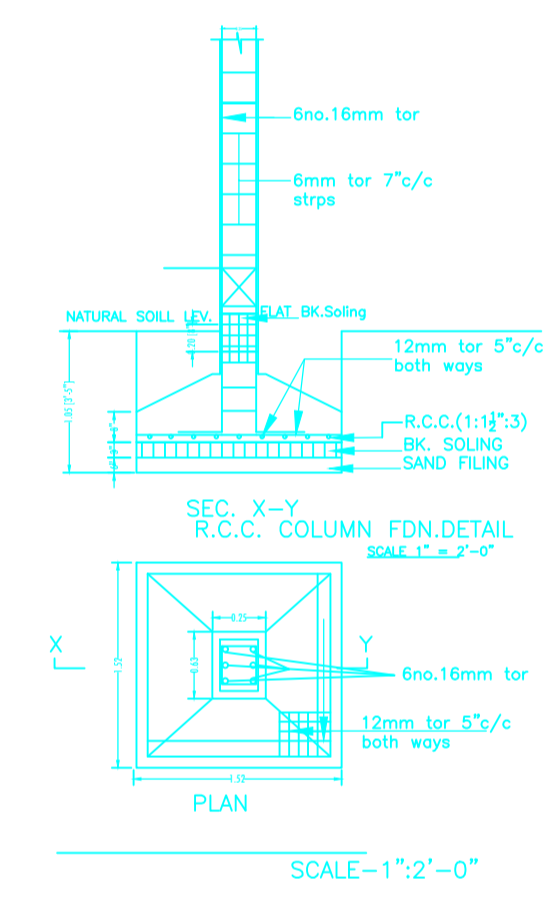
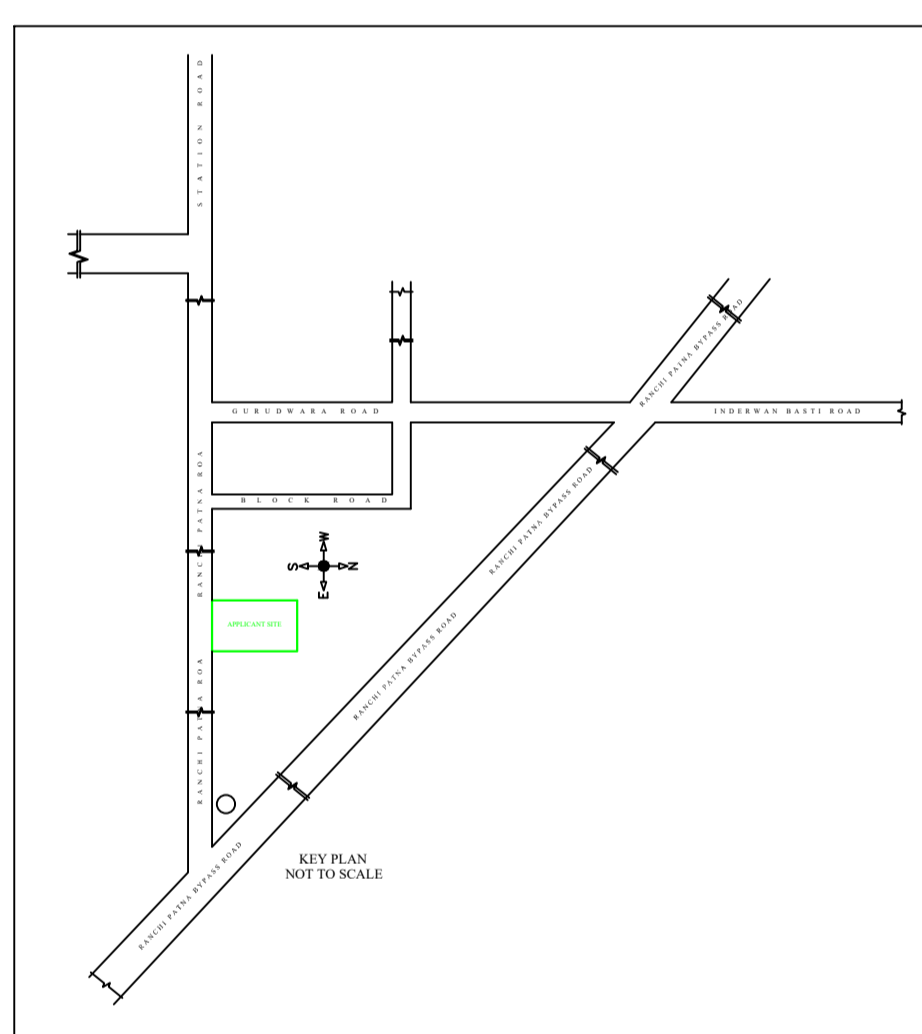
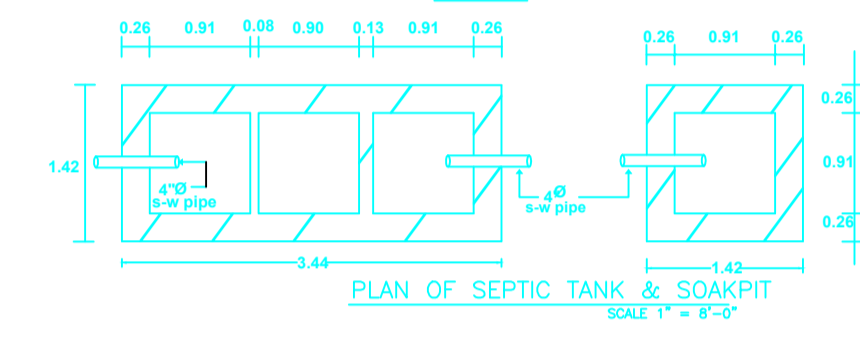
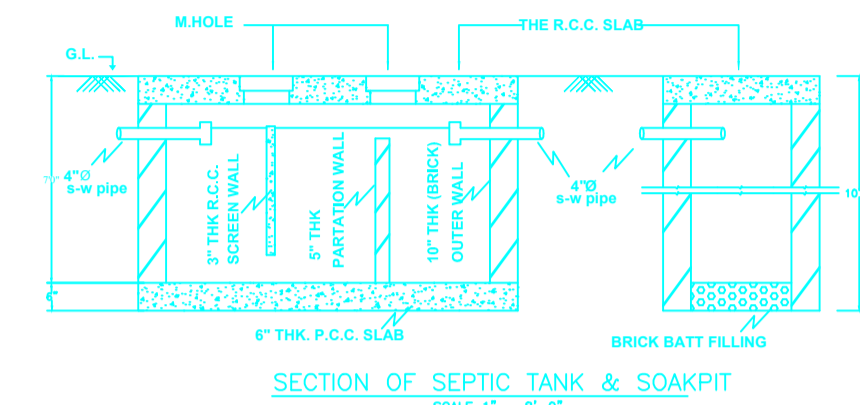

AREA STATEMENT
JHUMRITILAIYA NAGAR PARISHAD
VERSION NO. : 1.0.35
VERSION DATE: 13/03/2019

PROJECT DETAIL:
Region: JHARKHAND URBAN LOCAL BODIES
District: KODERMA
Authority: JHUMRITILAIYA NAGAR PARISHAD
Inward No: JNP/IBP/0019/W11/2019
Application Type: General Proposal
Project Type: Building Permission
Nature of Development: New
Location of Development Area: Old Area

Plot Use: Residential
Plot SubUse: Bungalow/ Dwelling / Non Apartment
PlotNearby/ReligiousStructure: NA
North: Plot No. - LAND OF SUJHIR KUMAR BHADANI & OTHERS
South: Road Width - 30M WIDE RANCHI PATNA ROAD
East: Plot No. - LAND OF DILIP KUMAR BARAHPURIA

AREA DETAILS:		SQ.MT.
AREA OF PLOT (Minimum)	(A)	
NET AREA OF PLOT(Gross Plot Area - Deduction from Gross Plot area)	(A-Deductions)	37.15
Deduction for Balance Plot Area(from Gross Plot Area)		
Common Plot		4.14
BALANCE AREA OF PLOT(Net Plot Area - Recreational/Amenity space)	(A-Deductions)	33.01
PLOT AREA FOR COVERAGE(Net Plot Area)		37.15
Plot Area for FAR (Net Plot Area + RoadWidening Area)	(A-Deductions)	37.15
COVERAGE CHECK		
Permissible Coverage area (70.00 %)		26.01
Proposed Coverage Area (57.58 %)		21.39
Total Prop. Coverage Area (57.58 %)		21.39
Balance coverage area (12.44 %)		4.62
FAR CHECK		
Perm. FAR Area (2.00)		74.30
Total Perm. FAR area		74.30
Residential FAR		64.17
Proposed FAR Area		64.17
Total Proposed FAR Area		64.17
Consumed FAR (Factor)		1.73
Balance FAR Area		10.13
BUILT UP AREA CHECK		64.17
Total Proposed BuiltUp Area		64.17
ARCHITECT (Regd)	MD SHOAB ALAM	
ENGINEER (Regd)		
SUPERVISOR (Regd)		
OWNER (Regd)	1. RITESH KUMAR DUGAR 2. MUKESH KUMAR DUGAR	
DEVELOPMENT AUTHORITY	LOCAL BODY	

COLOR INDEX

PLOT BOUNDARY	Black
ABUTTING ROAD	Green
PROPOSED CONSTRUCTION	Red
COMMON PLOT	Yellow
ROAD WIDENING AREA	Blue
EXISTING (To be retained)	Orange
EXISTING (To be demolished)	White

Buildingwise Floor FAR Details

Floor Name	Building Name		Total	
	Proposed Built Up Area (Sq.mt.)	Proposed FAR Area (Sq.mt.)	Total Proposed Built Up Area (Sq.mt.)	Total FAR Area (Sq.mt.)
Basement Floor	21.39	21.39	21.39	21.39
Ground Floor	21.39	21.39	21.39	21.39
First Floor	21.39	21.39	21.39	21.39
Terrace Floor	0.00	0.00	0.00	0.00
Total :	64.17	64.17	64.17	64.17

Building USE/SUBUSE Details

Building Name	Building Use	Building SubUse	Building Structure
AAA (RITESH DUGAR MUKESH DUGAR)	Residential	Bungalow/ Dwelling / Non Apartment	Non-Highrise

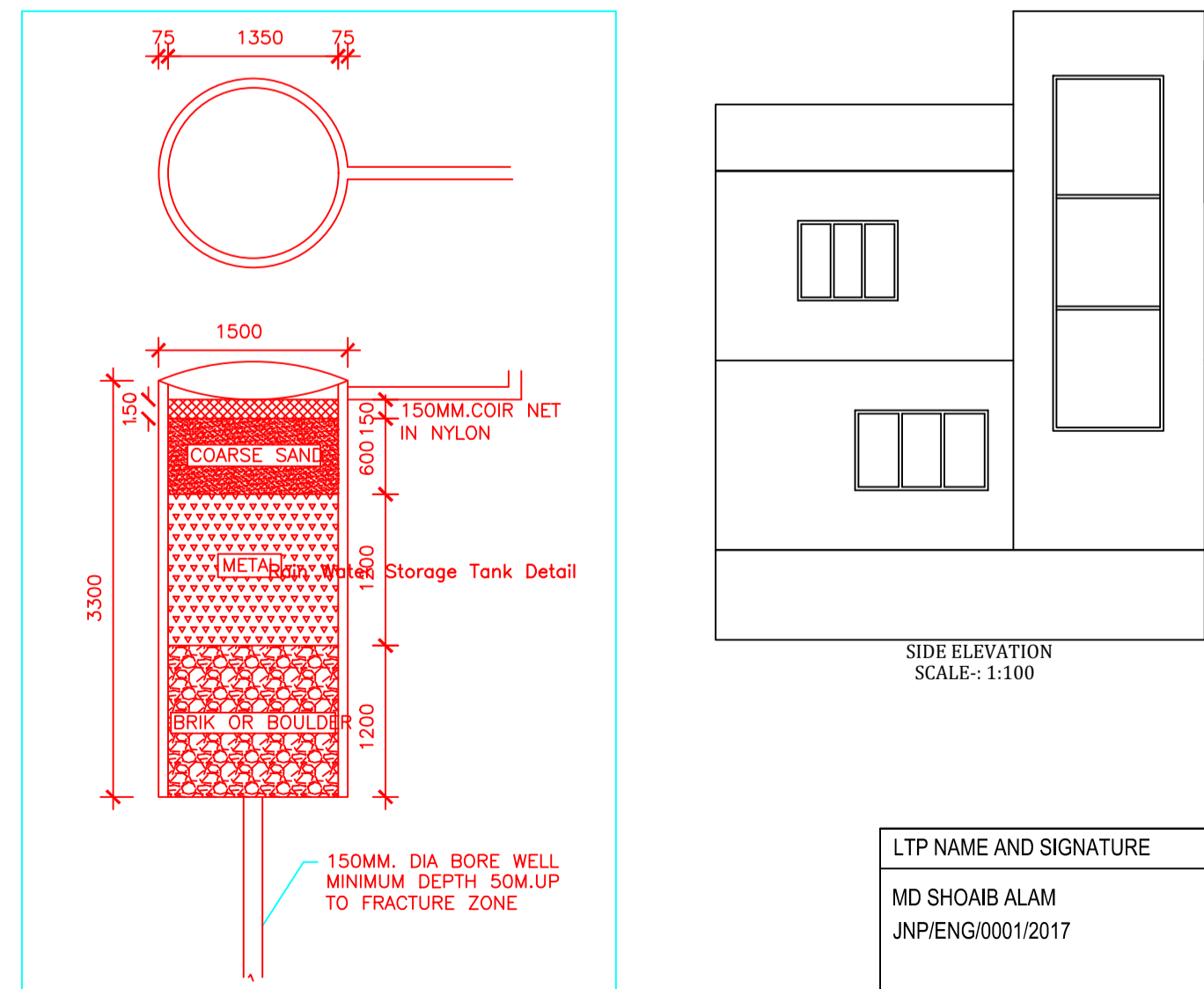

LTP NAME AND SIGNATURE	STRUCTURAL ENG'S NAME AND SIGNATURE	BUILDER NAME AND SIGNATURE	DIGITAL SIGNATURE
MD SHOAB ALAM JNP/ENG/001/2017			