

BABITA DEVI SITE PLAN

FAR & Tenement Details (Table 4c-1)

Building	No. of Same Bldg	Total Built Up Area (Sq.mt.)	Deductions (Area in Sq.mt.) Parking	Proposed FAR Area (Sq.mt.) Resi.	Total FAR Area (Sq.mt.)	Total Consumed Additional FAR Area (Sq.mt.)	Tnmt (No.)
A (BABITA DEVI HOUSE)	1	210.35	18.37	191.98	191.98	191.98	01
Grand Total :	1	210.35	18.37	191.98	191.98	191.98	01

Proposal Basic Information

Proposal File No.	JNP/BP/0045/W02/2019
Owner Name	BABITA DEVI
Khata No	145
Plot No	3228
Village Name	Tilaiya
Use	Residential
SubUse	Bungalow/ Dwelling / Non Apartment

AREA STATEMENT	VERSION NO. : 1.0.41
JHUMRITILAIYA NAGAR PARISHAD	VERSION DATE: 29/04/2019
PROJECT DETAIL:	
Region: JHARKHAND URBAN LOCAL BODIES	Plot Use: Residential
District: KODERMA	Plot SubUse: Bungalow/ Dwelling / Non Apartment
Authority: JHUMRITILAIYA NAGAR PARISHAD	PlotNearbyReligiousStructure: NA
Inward No: JNP/BP/0045/W02/2019	Plot/SubPlot No: 3228
Application Type: General Proposal	North: Road Width - 3.048
Project Type: Building Permission	South: Plot No. - RAM KISUN CHOUDHARY & OTHERS(P. N. -3228(P)
Nature of Development: New	East: Plot No. - PLOT No - 3228(P)
Location of Development Area: Old Area	West: Road Width - 3.65
AREA DETAILS:	
AREA OF PLOT (Minimum)	(A) 258.46
NET AREA OF PLOT (Gross Plot Area - Deduction from Gross Plot Area)	(A-Deductions) 258.46
Deduction for Balance Plot Area (from Gross Plot Area)	
Common Plot	30.17
BALANCE AREA OF PLOT (Net Plot Area - Recreational/Amenity space)	(A-Deductions) 228.28
PLOT AREA FOR COVERAGE (Net Plot Area)	(A-Deductions) 258.46
Plot Area for FAR (Net Plot Area + Road Widening Area)	(A-Deductions) 258.46
COVERAGE CHECK	
Permissible Coverage area (60.00 %)	155.08
Proposed Coverage Area (40.69 %)	105.17
Total Prop. Coverage Area (40.69 %)	105.17
Balance coverage area (19.31 %)	49.91
FAR CHECK	
Perm. FAR Area (1.50)	387.69
Total Perm. FAR area	387.69
Residential FAR	191.98
Proposed FAR Area	191.98
Total Proposed FAR Area	191.98
Consumed FAR (Factor)	0.74
Balance FAR Area	195.71
BUILT UP AREA CHECK	
Total Proposed BuiltUp Area	210.35
ARCHITECT (Regd)	UPENDRA
ENGINEER (Regd)	
SUPERVISOR (Regd)	
OWNER (Regd)	BABITA DEVI
DEVELOPMENT AUTHORITY LOCAL BODY	

COLOR INDEX	
PLOT BOUNDARY	Black
ABUTTING ROAD	Green
PROPOSED CONSTRUCTION	Red
COMMON PLOT	Yellow
ROAD WIDENING AREA	Blue
EXISTING (To be retained)	Blue
EXISTING (To be demolished)	Yellow

Buildingwise Floor FAR Details

Floor Name	Building Name A (BABITA DEVI HOUSE)		Total	
	Proposed Built Up Area (Sq.mt.)	Proposed FAR Area (Sq.mt.)	Total Proposed Built Up Area (Sq.mt.)	Total FAR Area (Sq.mt.)
Ground Floor	105.18	86.81	105.18	86.81
First Floor	105.17	105.17	105.17	105.17
Terrace Floor	0.00	0.00	0.00	0.00
Total :	210.35	191.98	210.35	191.98

Building USE/SUBUSE Details

Building Name	Building Use	Building SubUse	Building Structure
A (BABITA DEVI HOUSE)	Residential	Bungalow/ Dwelling / Non Apartment	Non-Highrise

LTP NAME AND SIGNATURE	STRUCTURAL ENG'S NAME AND SIGNATURE	BUILDER NAME AND SIGNATURE	DIGITAL SIGNATURE
UPENDRA JNP/ENG/0012/2017			

Proposal Basic Information

Proposal File No.	JNP/EP/0045/W02/2019
Owner Name	BABITA DEVI
Khata No	145
Plot No	3228
Village Name	Tilaiya
Use	Residential
SubUse	Bungalow/ Dwelling / Non Apartment

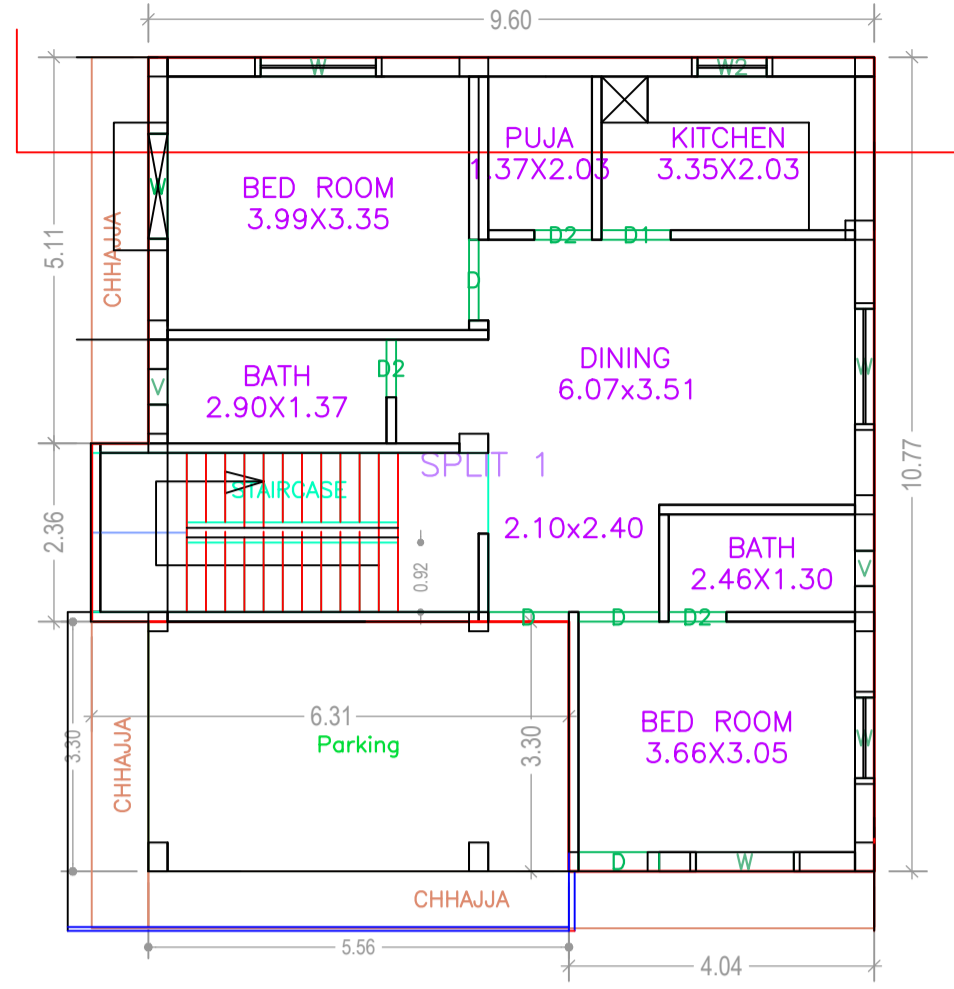

GROUND FLOOR PLAN (Proposed) (SCALE 1:100)

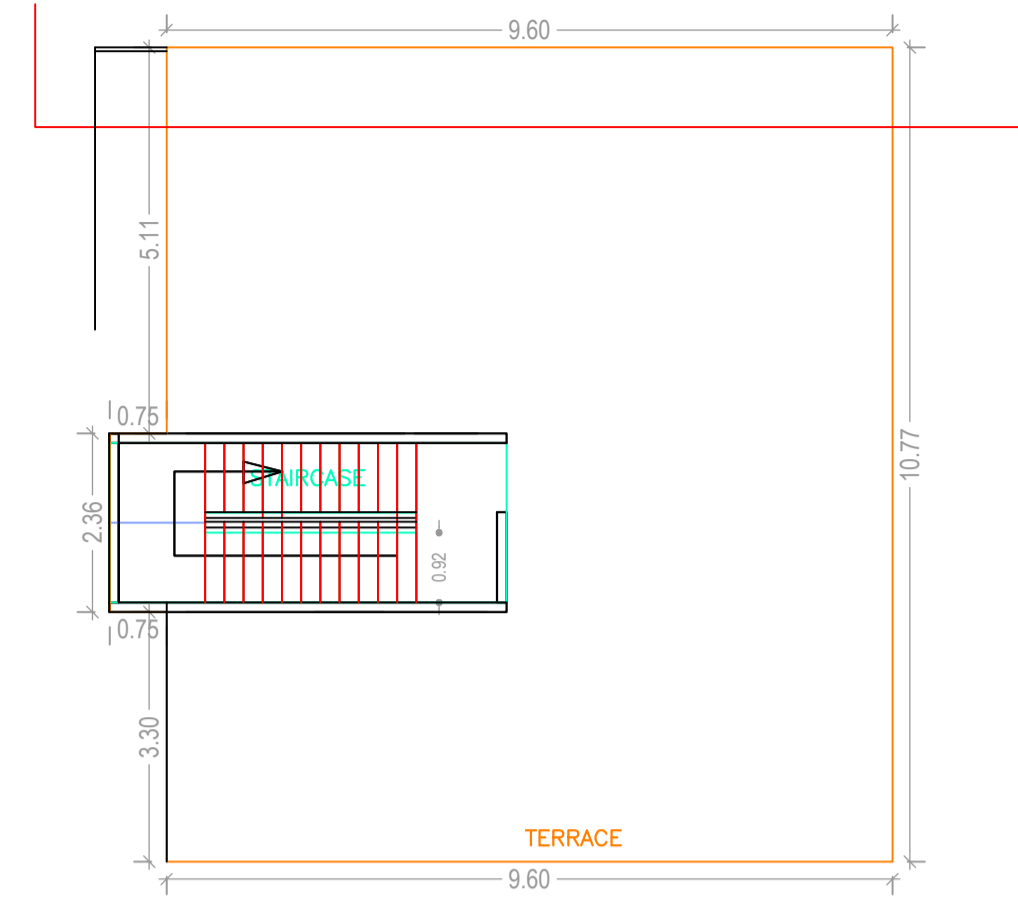

TERRACE FLOOR PLAN (SCALE 1:100)

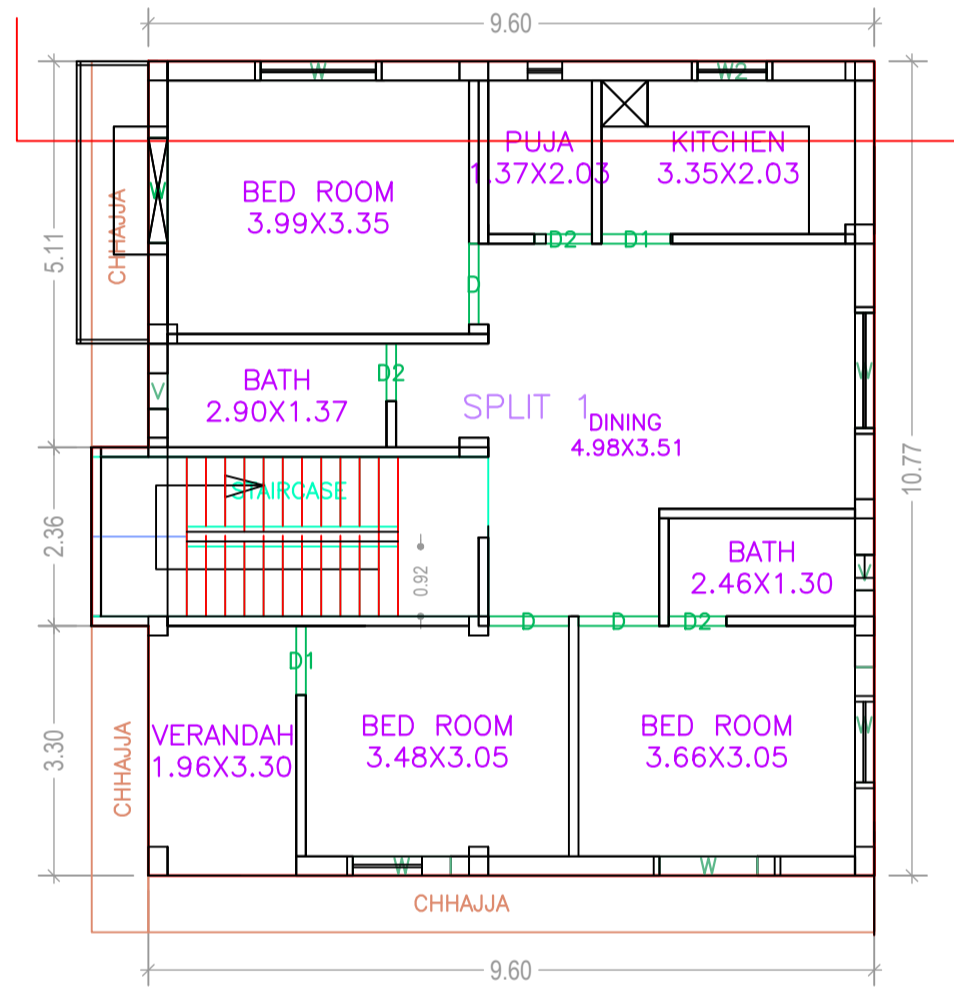

FIRST FLOOR PLAN (Proposed) (SCALE 1:100)

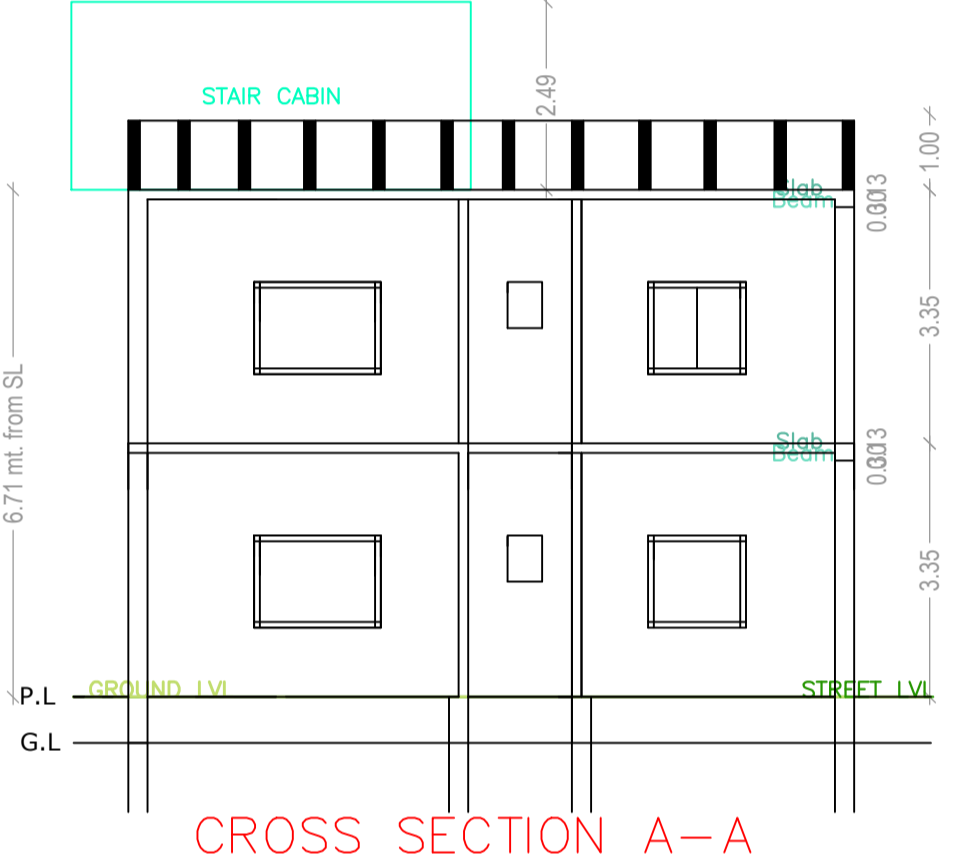

CROSS SECTION A-A

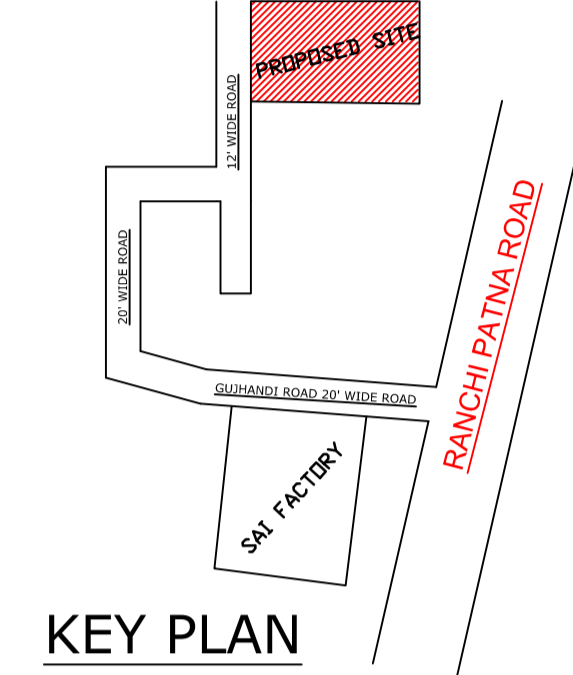

KEY PLAN

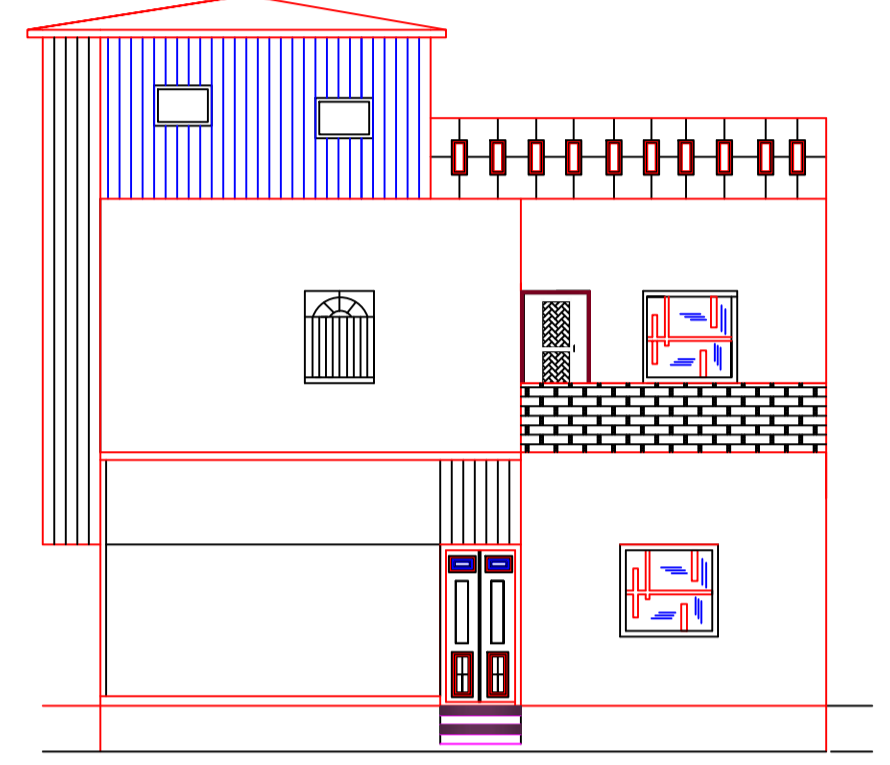

FRONT ELEVATION

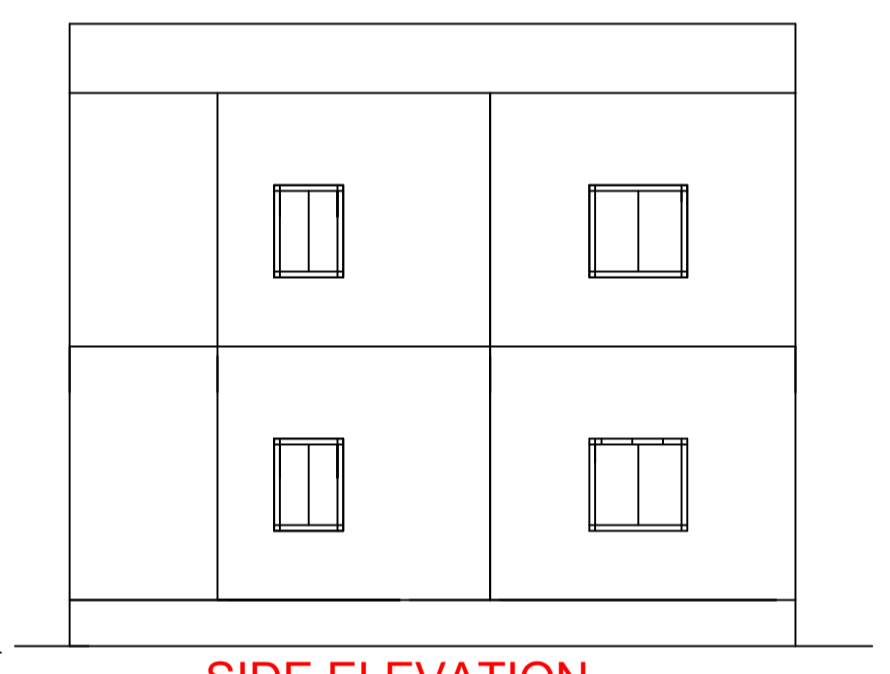

SIDE ELEVATION

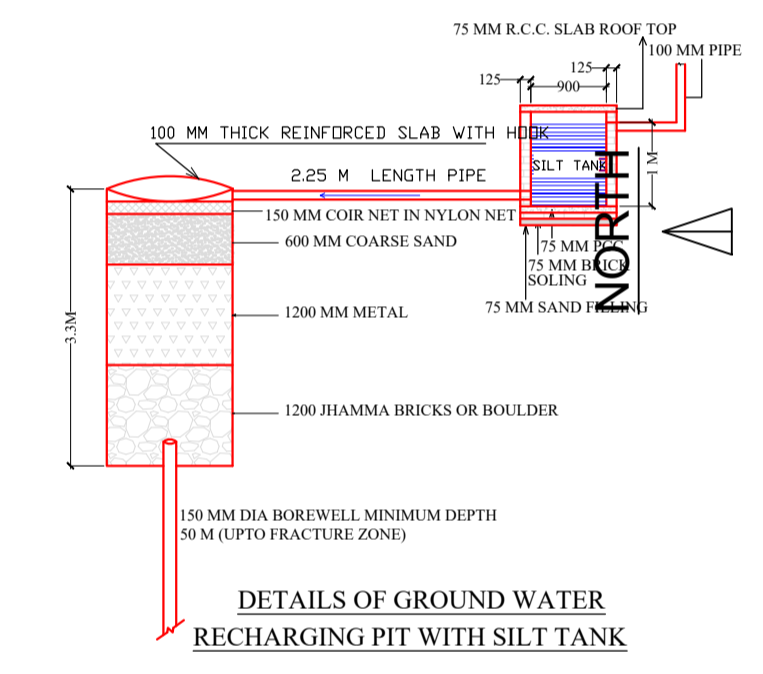

DETAILS OF GROUND WATER RECHARGING PIT WITH SILT TANK

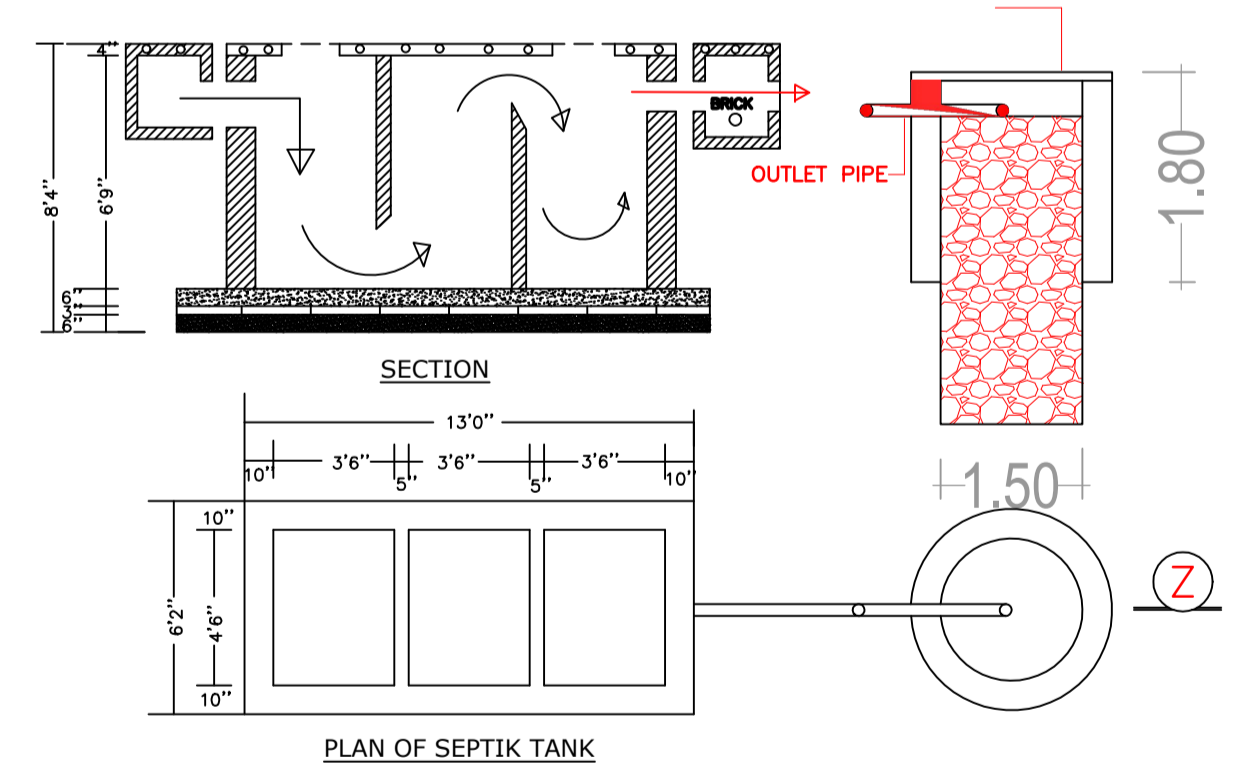
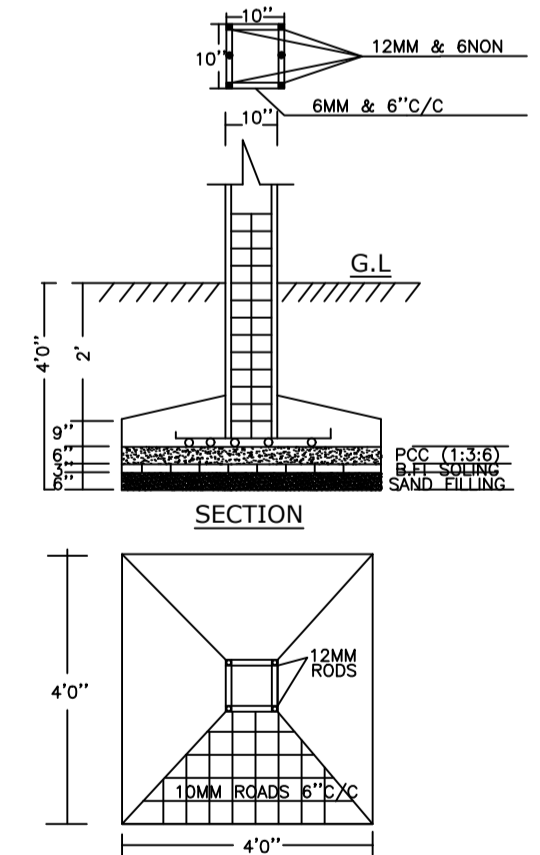

PLAN OF SEPTIK TANK

SCHEDULE OF DOOR:

BUILDING NAME	NAME	LENGTH	HEIGHT	NOS
A (BABITA DEVI HOUSE)	D2	0.76	2.10	06
A (BABITA DEVI HOUSE)	D1	0.91	2.10	03
A (BABITA DEVI HOUSE)	D	1.07	2.10	07
A (BABITA DEVI HOUSE)	W	1.39	2.10	02

SCHEDULE OF WINDOW/VENTILATION:

BUILDING NAME	NAME	LENGTH	HEIGHT	NOS
A (BABITA DEVI HOUSE)	V	0.47	1.20	04
A (BABITA DEVI HOUSE)	W2	0.91	1.20	02
A (BABITA DEVI HOUSE)	W	1.07	1.20	01
A (BABITA DEVI HOUSE)	W	1.30	1.20	03
A (BABITA DEVI HOUSE)	W	1.52	1.20	04

UnitBUA Table for Building :A (BABITA DEVI HOUSE)

FLOOR	Name	UnitBUA Type	UnitBUA Area	Carpet Area	No. of Rooms	No. of Tenement
GROUND FLOOR PLAN	SPLIT 1	FLAT	191.98	172.99	7	1
FIRST FLOOR PLAN	SPLIT 1	FLAT	0.00	0.00	8	0
Total:	-	-	191.98	172.99	15	1

Building :A (BABITA DEVI HOUSE)

Floor Name	Total Built Up Area (Sq.mt.)	Deductions (Area in Sq.mt.)	Proposed FAR Area (Sq.mt.)	Total FAR Area (Sq.mt.)	Total Consumed Additional FAR Area (Sq.mt.)	Trmt (No.)
Ground Floor	18.37	18.37	86.81	86.81	86.81	01
First Floor	105.17	0.00	105.17	105.17	105.17	00
Terrace Floor	0.00	0.00	0.00	0.00	0.00	00
Total:	210.35	18.37	191.98	191.98	191.98	01
Total Number of Same Buildings	1					
Total:	210.35	18.37	191.98	191.98	191.98	01

LTP NAME AND SIGNATURE	STRUCTURAL ENG'S NAME AND SIGNATURE	BUILDER NAME AND SIGNATURE	DIGITAL SIGNATURE
UPENDRA JNP/ENG/0012/2017			