

FAR & Tenement Details (Table 4c-1)

Building	No. of Same Bldg	Total Built Up Area (Sq.mt.)	Proposed FAR Area (Sq.mt.) Resi.	Total FAR Area (Sq.mt.)	Total Consumed Additional FAR Area (Sq.mt.)	Tnmt (No.)
A (MALTI DEVI HOUSE)	1	185.32	185.32	185.32	185.32	01
Grand Total:	1	185.32	185.32	185.32	185.32	01

Proposal Basic Information

Proposal File No.	JNP/IBP/0043/W01/2019
Owner Name	MALTI DEVI
Khata No	25
Plot No	46/888
Village Name	Nawada
Use	Residential
SubUse	Bungalow/ Dwelling / Non Apartment

AREA STATEMENT

AREA OF PLOT (Minimum)	(A)	SQ.MT.
AREA OF PLOT (Minimum)	(A)	161.51
Deduction for NetPlot Area		
Road Widening Area		6.36
Total		6.36
NET AREA OF PLOT(Gross Plot Area - Deduction from Gross Plot area)	(A-Deductions)	155.15
Deduction for Balance Plot Area(from Gross Plot Area)		
Road Widening Area		6.36
Common Plot		20.74
Total		27.10
BALANCE AREA OF PLOT(Net Plot Area - Recreational/Amenity space)	(A-Deductions)	134.41
PLOT AREA FOR COVERAGE(Net Plot Area)	(A-Deductions)	155.15
Plot Area for FAR (Net Plot Area + RoadWidening Area)	(A-Deductions)	155.15
COVERAGE CHECK		
Permissible Coverage area (70.00 %)		108.60
Proposed Coverage Area (59.72 %)		92.66
Total Prop. Coverage Area (59.72 %)		92.66
Balance coverage area (10.27 %)		15.94
FAR CHECK		
Perm. FAR Area (1.50)		232.72
Total Perm. FAR area		232.72
Residential FAR		185.32
Proposed FAR Area		185.32
Total Proposed FAR Area		185.32
Consumed FAR (Factor)		1.19
Balance FAR Area		47.40
BUILT UP AREA CHECK		
Total Proposed BuiltUp Area		185.32
ARCHITECT (Regd)	UPENDRA	
ENGINEER (Regd)		
SUPERVISOR (Regd)		
OWNER (Regd)	MALTI DEVI	
DEVELOPMENT AUTHORITY	LOCAL BODY	

COLOR INDEX

PLOT BOUNDARY	Black
ABUTTING ROAD	Red
PROPOSED CONSTRUCTION	Green
COMMON PLOT	Yellow
ROAD WIDENING AREA	Blue
EXISTING (To be retained)	Light Blue
EXISTING (To be demolished)	Light Yellow

Building :A (MALTI DEVI HOUSE)

Floor Name	Total Built Up Area (Sq.mt.)	Proposed FAR Area (Sq.mt.) Resi.	Total FAR Area (Sq.mt.)	Total Consumed Additional FAR Area (Sq.mt.)	Tnmt (No.)
Ground Floor	92.66	92.66	92.66	92.66	01
First Floor	92.66	92.66	92.66	92.66	00
Terrace Floor	0.00	0.00	0.00	0.00	00
Total:	185.32	185.32	185.32	185.32	01
Total Number of Same Buildings	1				
Total:	185.32	185.32	185.32	185.32	01

SCHEDULE OF DOOR:

BUILDING NAME	NAME	LENGTH	HEIGHT	NOS
A (MALTI DEVI HOUSE)	D2	0.76	2.10	02
A (MALTI DEVI HOUSE)	D1	0.91	2.10	04
A (MALTI DEVI HOUSE)	D	1.07	2.10	08

SCHEDULE OF WINDOW/VENTILATION:

BUILDING NAME	NAME	LENGTH	HEIGHT	NOS
A (MALTI DEVI HOUSE)	V	0.46	1.20	04
A (MALTI DEVI HOUSE)	W1	0.91	1.20	02
A (MALTI DEVI HOUSE)	W	1.22	1.20	06
A (MALTI DEVI HOUSE)	W	1.37	1.20	02
A (MALTI DEVI HOUSE)	W	1.52	1.20	02

UnitBUA Table for Building :A (MALTI DEVI HOUSE)

FLOOR	Name	UnitBUA Type	UnitBUA Area	Carpet Area	No. of Rooms	No. of Tenement
GROUND FLOOR PLAN	SPLIT 1	FLAT	185.32	165.51	8	1
FIRST FLOOR PLAN	SPLIT 1	FLAT	0.00	0.00	8	0
Total:	-	-	185.32	165.51	16	1

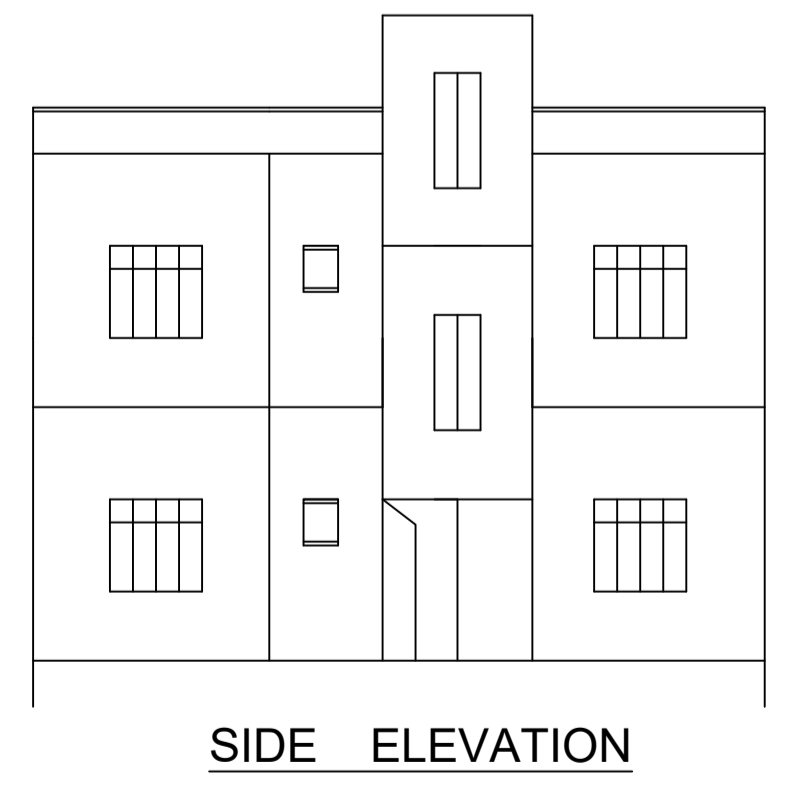
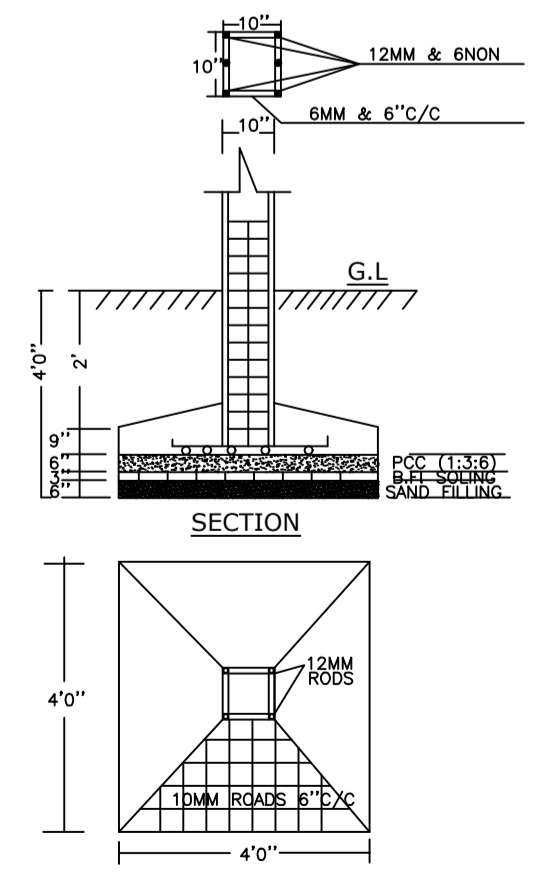

Buildingwise Floor FAR Details

Floor Name	Building Name A (MALTI DEVI HOUSE)		Total	
	Proposed Built Up Area (Sq.mt.)	Proposed FAR Area (Sq.mt.)	Total Proposed Built Up Area (Sq.mt.)	Total FAR Area (Sq.mt.)
Ground Floor	92.66	92.66	92.66	92.66
First Floor	92.66	92.66	92.66	92.66
Terrace Floor	0.00	0.00	0.00	0.00
Total:	185.32	185.32	185.32	185.32

Building USE/SUBUSE Details

Building Name	Building Use	Building SubUse	Building Structure
A (MALTI DEVI HOUSE)	Residential	Bungalow/ Dwelling / Non Apartment	Non-Highrise

LTP NAME AND SIGNATURE	STRUCTURAL ENG'S NAME AND SIGNATURE	BUILDER NAME AND SIGNATURE	DIGITAL SIGNATURE
UPENDRA JNP/ENG/0012/2017			