

GROUND FLOOR PLAN (Proposed) (SCALE 1:100)

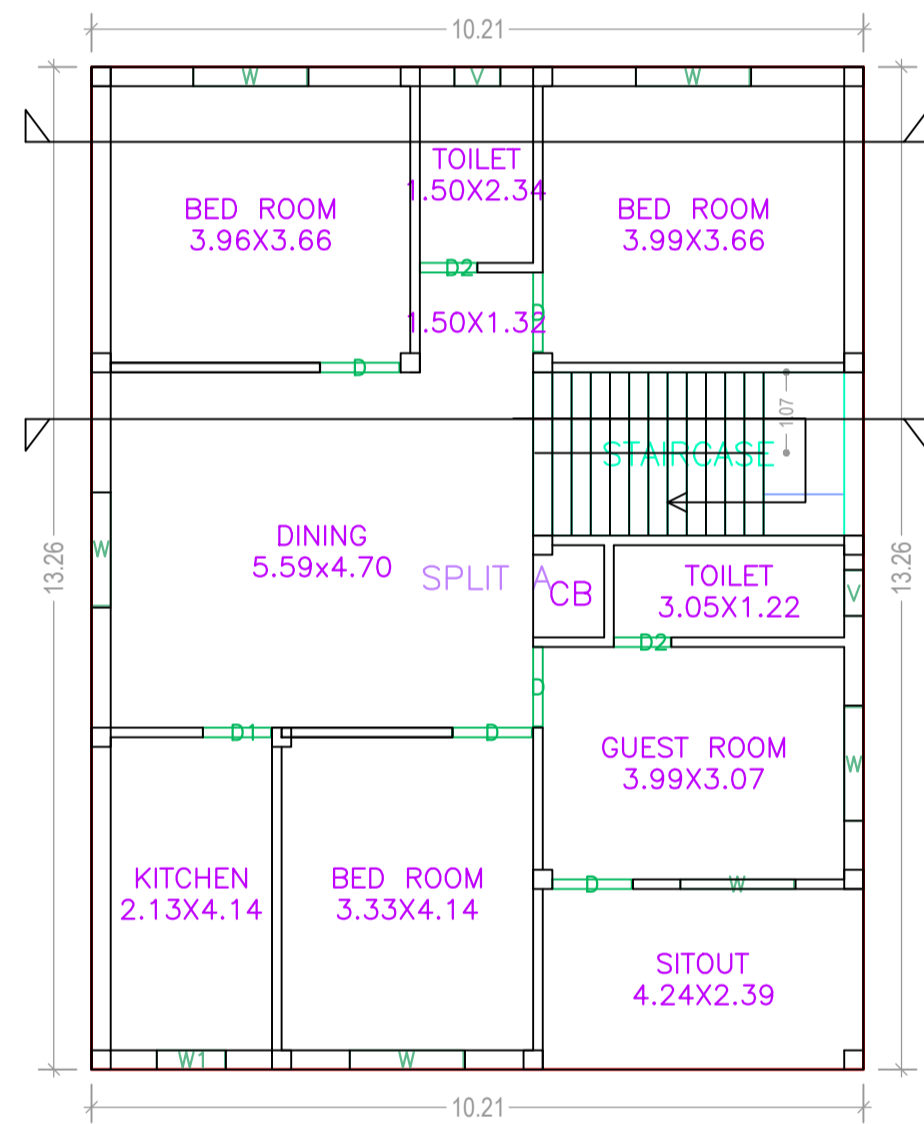

FIRST FLOOR PLAN (Proposed) (SCALE 1:100)

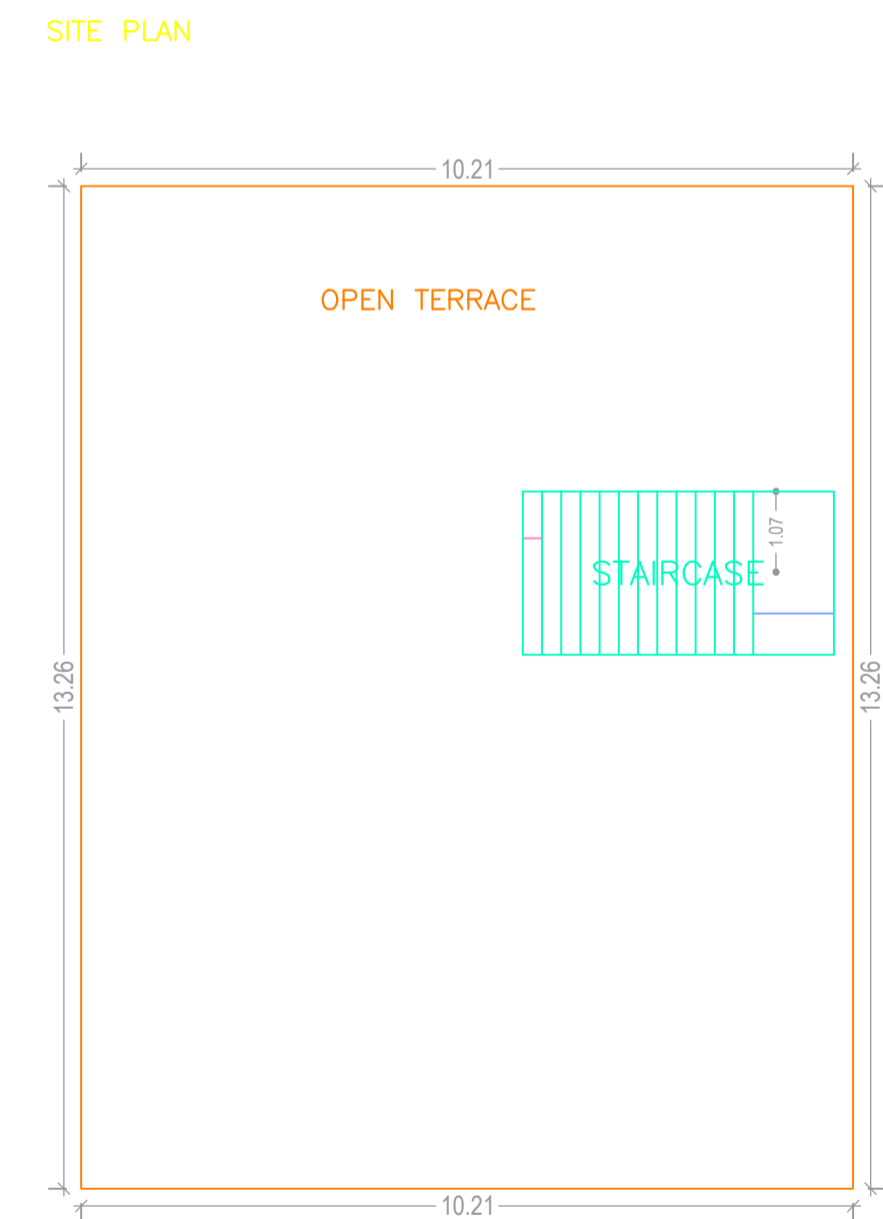

TERRACE FLOOR PLAN (SCALE 1:100)

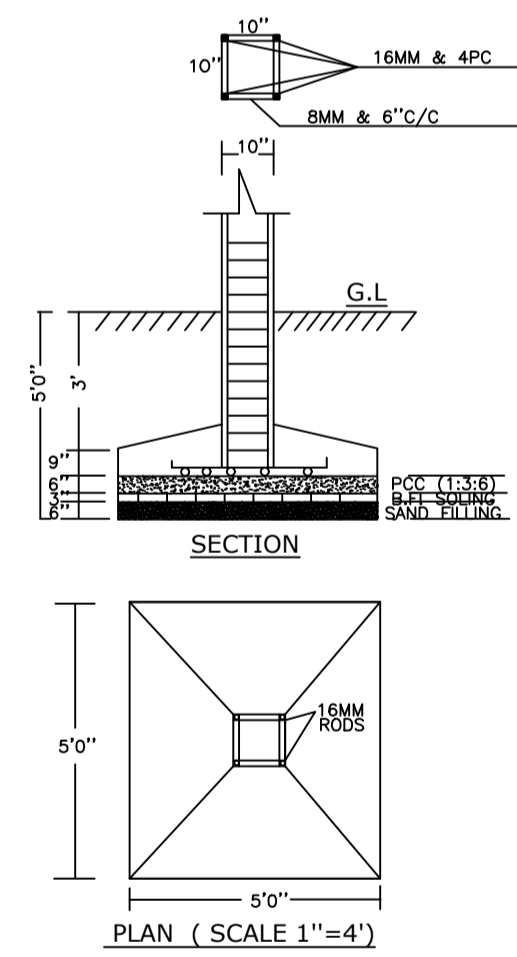

SECTION

PLAN (SCALE 1''=4')



FRONT ELEVATION

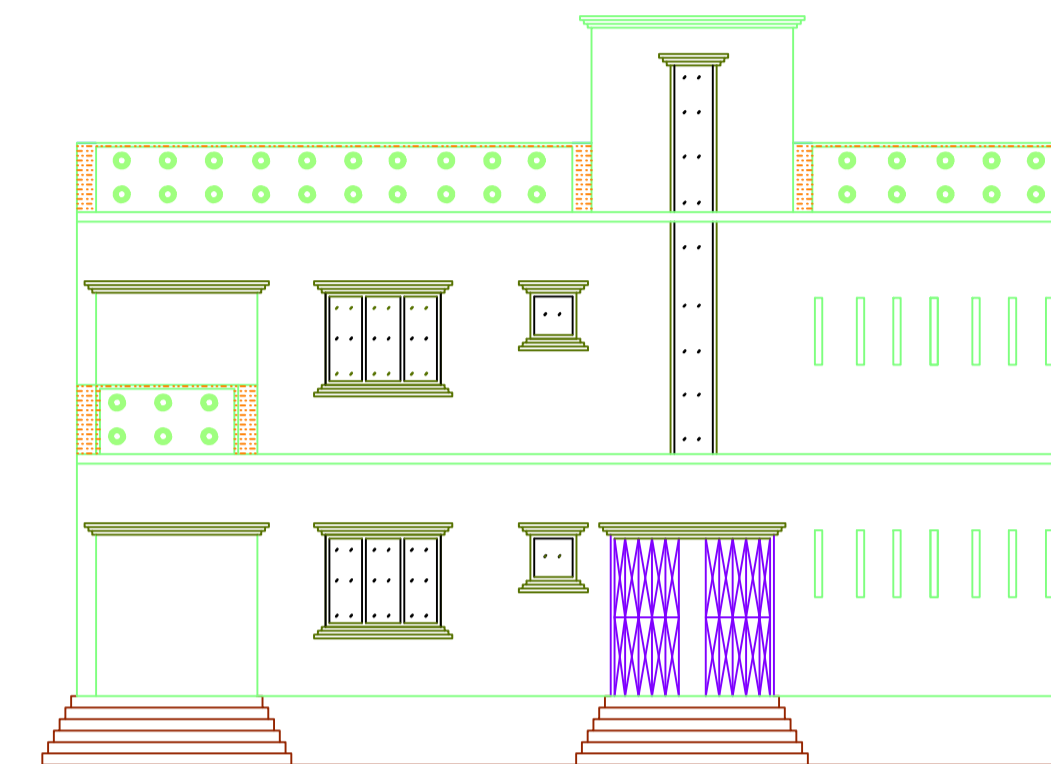

CROSS ELEVATION

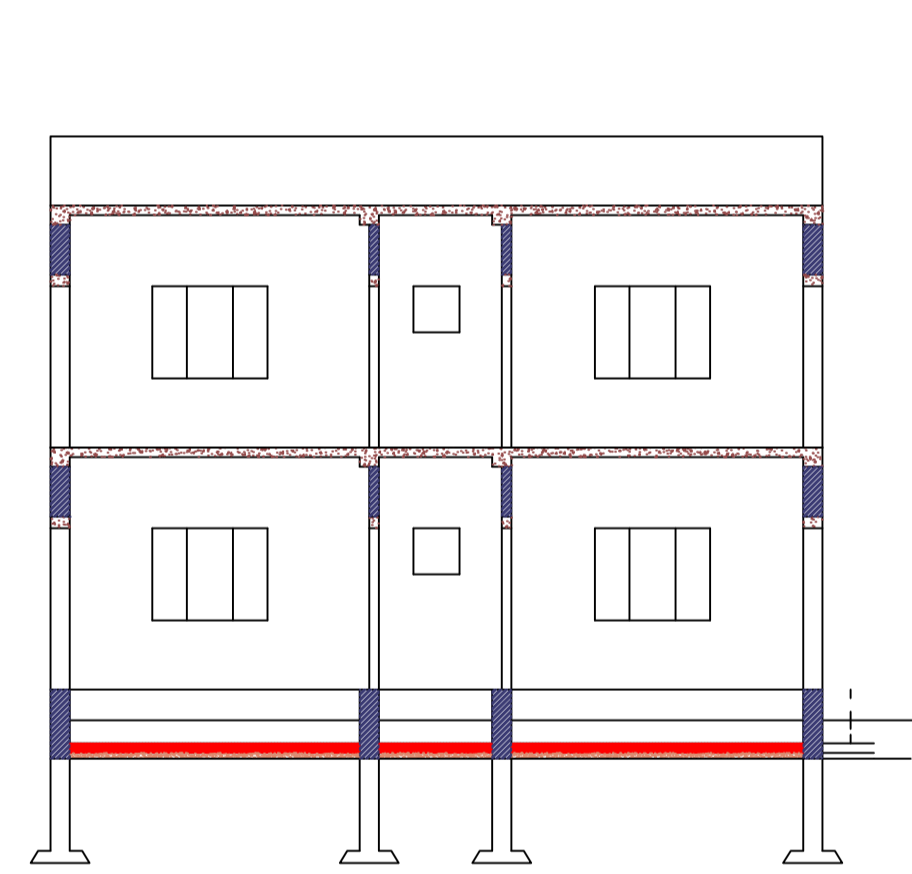

CROSS SECTION (B)

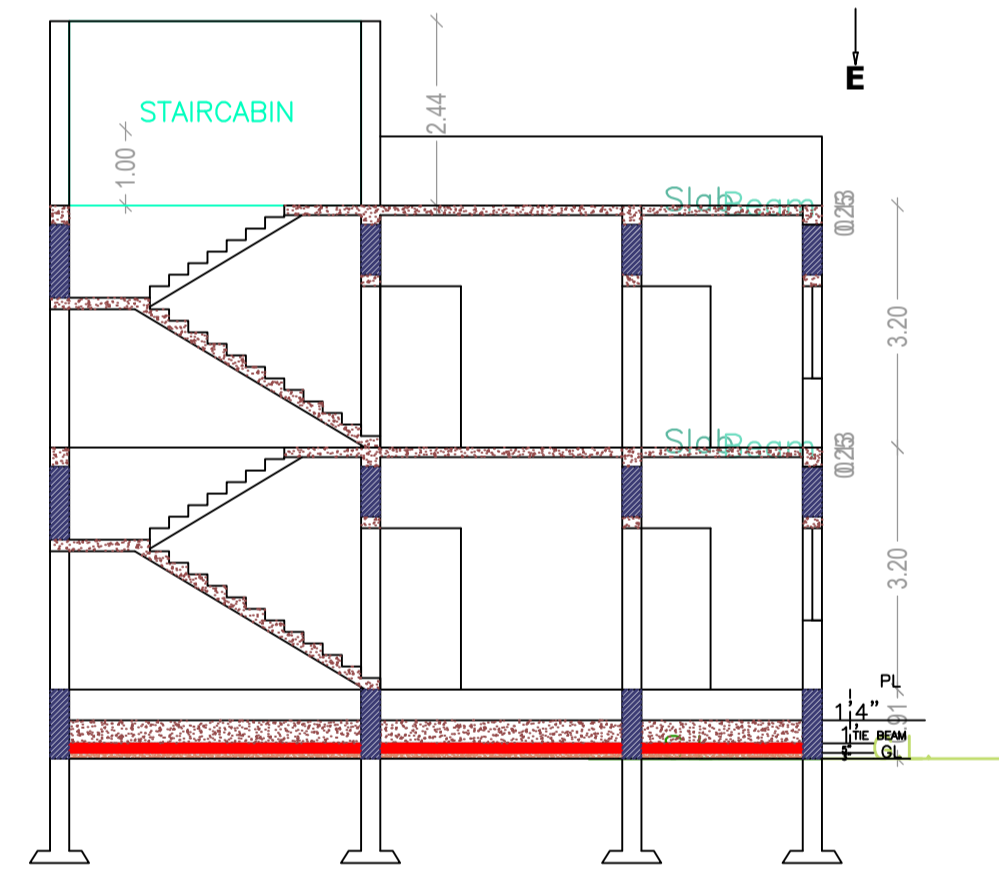

CROSS SECTION (A)

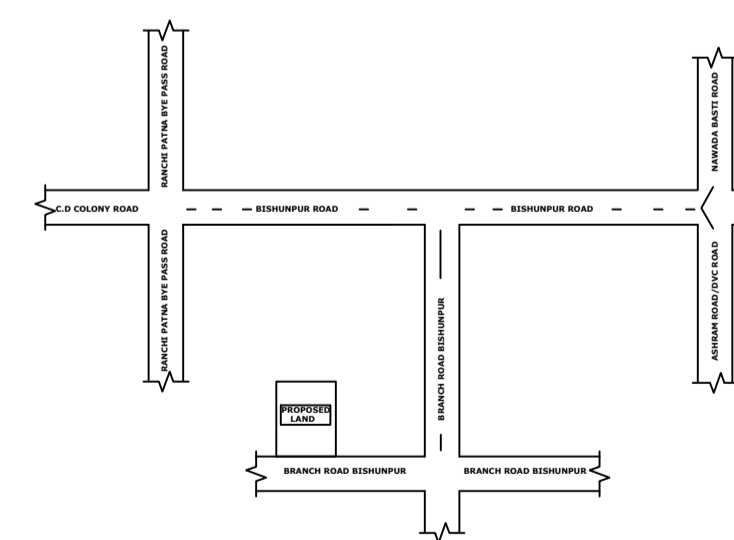

LOCATION PLAN (SCALE -1''=16')

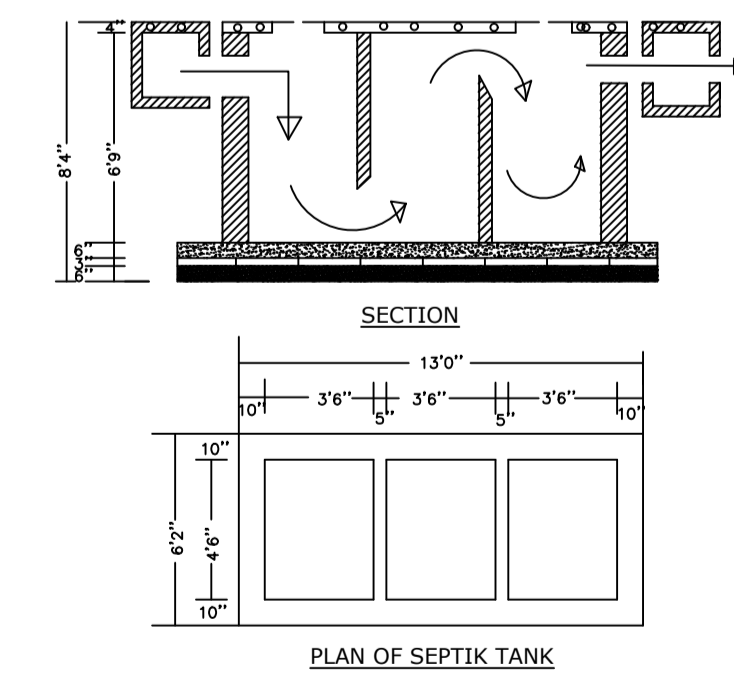

PLAN OF SEPTIC TANK

FAR & Tenement Details (Table 4c-1)

Building	No. of Same Bldg	Total Built Up Area (Sq.mt.)	Proposed FAR Area (Sq.mt.) Resi.	Total FAR Area (Sq.mt.)	Total Consumed Additional FAR Area (Sq.mt.)	Tnmt (No.)
A (RESIDENTIAL)	1	270.76	270.76	270.76	270.76	01
Grand Total :	1	270.76	270.76	270.76	270.76	01

Proposal Basic Information

Proposal File No.	JNP/BP/0048/W01/2019
Owner Name	ASHA KUMARI
Khata No	944
Plot No	3995,3996
Village Name	Tilaiya
Use	Residential
SubUse	Bungalow/ Dwelling / Non Apartment

AREA STATEMENT		VERSION NO. : 1.0.41
JHUMRITILAIYA NAGAR PARISHAD		VERSION DATE: 29/04/2019
PROJECT DETAIL:		
Region: JHARKHAND URBAN LOCAL BODIES	Plot Use: Residential	
District: KODERMA	Plot SubUse: Bungalow/ Dwelling / Non Apartment	
Authority: JHUMRITILAIYA NAGAR PARISHAD	PlotNearbyReligiousStructure: NA	
Inward No: JNP/BP/0048/W01/2019	PlotSubPlot No: 3995,3996	
Application Type: General Proposal	North: Plot No. - 3999,3996	
Project Type: Building Permission	South: Plot No. - 3995 AND USHA KUMARI	
Nature of Development: New	East: Road Width - 4.8 M WIDE ROAD	
Location of Development Area: Old Area	West: Plot No. - 3995 AND NIU VENDOR	
AREA DETAILS:		
AREA OF PLOT (Minimum)	(A)	SQ.MT. 222.97
NET AREA OF PLOT(Gross Plot Area - Deduction from Gross Plot area)	(A-Deductions)	222.97
Deduction for Balance Plot Area(from Gross Plot Area)		
Common Plot		22.43
Total		22.43
BALANCE AREA OF PLOT(Net Plot Area - Recreational/Amenity space)	(A-Deductions)	200.54
PLOT AREA FOR COVERAGE(Net Plot Area)	(A-Deductions)	222.97
Plot Area for FAR (Net Plot Area + Road Widening Area)	(A-Deductions)	222.97
COVERAGE CHECK		
Permissible Coverage area ( 70.00 % )		156.08
Proposed Coverage Area ( 60.72 % )		135.38
Total Prop. Coverage Area ( 60.72 % )		135.38
Balance coverage area ( 9.28 % )		20.70
FAR CHECK		
Perm. FAR Area ( 1.80 )		401.35
Total Perm. FAR area		401.35
Residential FAR		270.77
Proposed FAR Area		270.77
Total Proposed FAR Area		270.77
Consumed FAR (Factor)		1.21
Balance FAR Area		130.58
BUILT UP AREA CHECK		
Total Proposed BuiltUp Area		270.76
ARCHITECT (Regd)	KIRAN KUMARI	
ENGINEER (Regd)		
SUPERVISOR (Regd)		
OWNER (Regd)	ASHA KUMARI	
DEVELOPMENT AUTHORITY		LOCAL BODY

COLOR INDEX	
PLOT BOUNDARY	Black
ABUTTING ROAD	Green
PROPOSED CONSTRUCTION	Red
COMMON PLOT	Yellow
ROAD WIDENING AREA	Blue
EXISTING (To be retained)	Light Blue
EXISTING (To be demolished)	Light Yellow

Buildingwise Floor FAR Details

Floor Name	Building Name A (RESIDENTIAL)		Total	
	Proposed Built Up Area (Sq.mt.)	Proposed FAR Area (Sq.mt.)	Total Proposed Built Up Area (Sq.mt.)	Total FAR Area (Sq.mt.)
Ground Floor	135.38	135.38	135.38	135.38
First Floor	135.38	135.38	135.38	135.38
Terrace Floor	0.00	0.00	0.00	0.00
Total :	270.76	270.76	270.76	270.76

Building USE/SUBUSE Details

Building Name	Building Use	Building SubUse	Building Structure
A (RESIDENTIAL)	Residential	Bungalow/ Dwelling / Non Apartment	Non-Highrise

Building :A (RESIDENTIAL)

Floor Name	Total Built Up Area (Sq.mt.)	Proposed FAR Area (Sq.mt.) Resi.	Total FAR Area (Sq.mt.)	Total Consumed Additional FAR Area (Sq.mt.)	Tnmt (No.)
Ground Floor	135.38	135.38	135.38	135.38	01
First Floor	135.38	135.38	135.38	135.38	00
Terrace Floor	0.00	0.00	0.00	0.00	00
Total :	270.76	270.76	270.76	270.76	01
Total Number of Same Buildings	1				
Total :	270.76	270.76	270.76	270.76	01

SCHEDULE OF DOOR:

BUILDING NAME	NAME	LENGTH	HEIGHT	NOS
A (RESIDENTIAL)	D2	0.75	2.10	04
A (RESIDENTIAL)	D1	0.90	2.10	02
A (RESIDENTIAL)	D	1.05	2.10	10

SCHEDULE OF WINDOW/VENTILATION:

BUILDING NAME	NAME	LENGTH	HEIGHT	NOS
A (RESIDENTIAL)	V	0.60	0.60	02
A (RESIDENTIAL)	V	0.60	0.90	02
A (RESIDENTIAL)	W1	0.90	1.20	02
A (RESIDENTIAL)	W	1.50	1.20	12

UnitBUA Table for Building :A (RESIDENTIAL)

FLOOR	Name	UnitBUA Type	UnitBUA Area	Carpet Area	No. of Rooms	No. of Tenement
GROUND FLOOR PLAN	SPLIT A	FLAT	230.82	229.54	9	1
FIRST FLOOR PLAN	SPLIT A	FLAT	0.00	0.00	9	0
Total:	-	-	230.82	229.54	18	1

LTP NAME AND SIGNATURE	STRUCTURAL ENG'S NAME AND SIGNATURE	BUILDER NAME AND SIGNATURE	DIGITAL SIGNATURE
KIRAN KUMARI JNP/ENG/0001/2019			