

FAR & Tenement Details (Table 4c-1)

Building	No. of Same Bldg	Total Built Up Area (Sq.mt.)	Proposed FAR Area (Sq.mt.) Resi.	Total FAR Area (Sq.mt.)	Total Consumed Additional FAR Area (Sq.mt.)	Tnmt (No.)
A (RESIDENTIAL)	1	206.54	206.54	206.54	206.54	01
Grand Total :	1	206.54	206.54	206.54	206.54	01

Proposal Basic Information

Proposal File No.	JNP/IBP/0046/W23/2019
Owner Name	AJAY KUMAR SINHA
Khata No	106
Plot No	5973
Village Name	Gomo
Use	Residential
SubUse	Bungalow/ Dwelling / Non Apartment

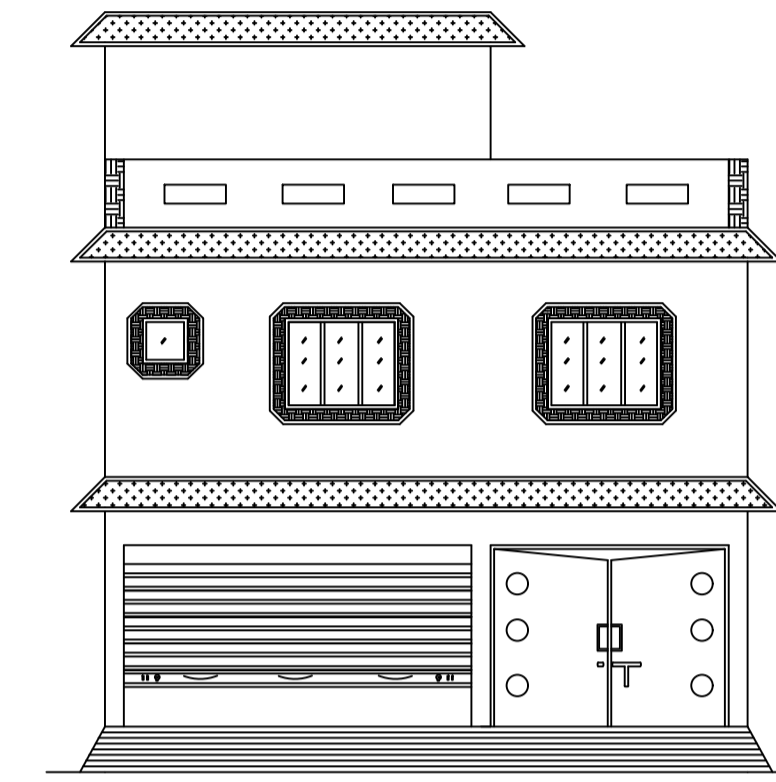

AREA STATEMENT

AREA DETAILS:		SQ.MT.
AREA OF PLOT (Minimum)	(A)	167.12
NET AREA OF PLOT(Gross Plot Area - Deduction from Gross Plot area)	(A-Deductions)	167.12
Deduction for Balance Plot Area:(from Gross Plot Area)		
Common Plot		16.88
Total		16.88
BALANCE AREA OF PLOT(Net Plot Area - Recreational/Amenity space)	(A-Deductions)	150.24
PLOT AREA FOR COVERAGE(Net Plot Area)	(A-Deductions)	167.12
Plot Area for FAR (Net Plot Area + RoadWidening Area)	(A-Deductions)	167.12
COVERAGE CHECK		
Permissible Coverage area (70.00 %)		116.98
Proposed Coverage Area (61.80 %)		103.27
Total Prop. Coverage Area (61.8 %)		103.27
Balance coverage area (8.20 %)		13.71
FAR CHECK		
Perm. FAR Area (1.50)		250.68
Total Perm. FAR area		250.68
Residential FAR		206.55
Proposed FAR Area		206.55
Total Proposed FAR Area		206.55
Consumed FAR (Factor)		1.24
Balance FAR Area		44.13
BUILT UP AREA CHECK		
Total Proposed BuiltUp Area		206.54
ARCHITECT (Regd)	KIRAN KUMARI	
ENGINEER (Regd)		
SUPERVISOR (Regd)		
OWNER (Regd)	AJAY KUMAR SINHA	
DEVELOPMENT AUTHORITY	LOCAL BODY	

SITE PLAN

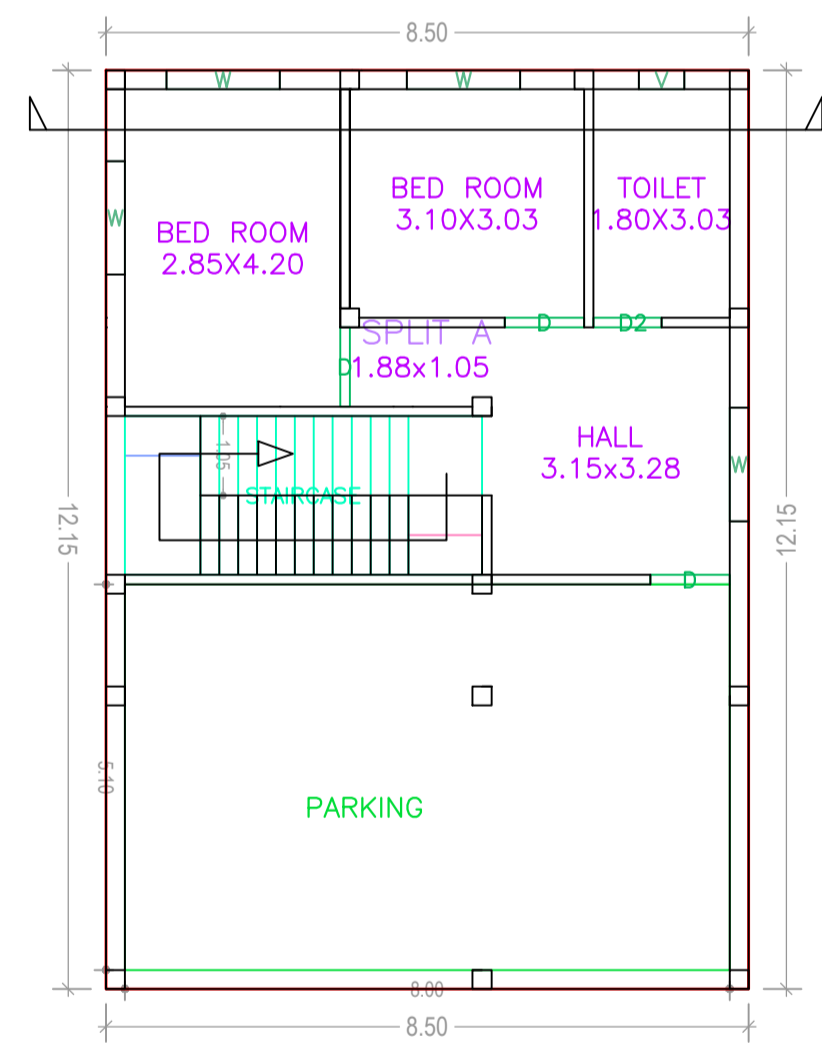

GROUND FLOOR PLAN (Proposed) (SCALE 1:100)

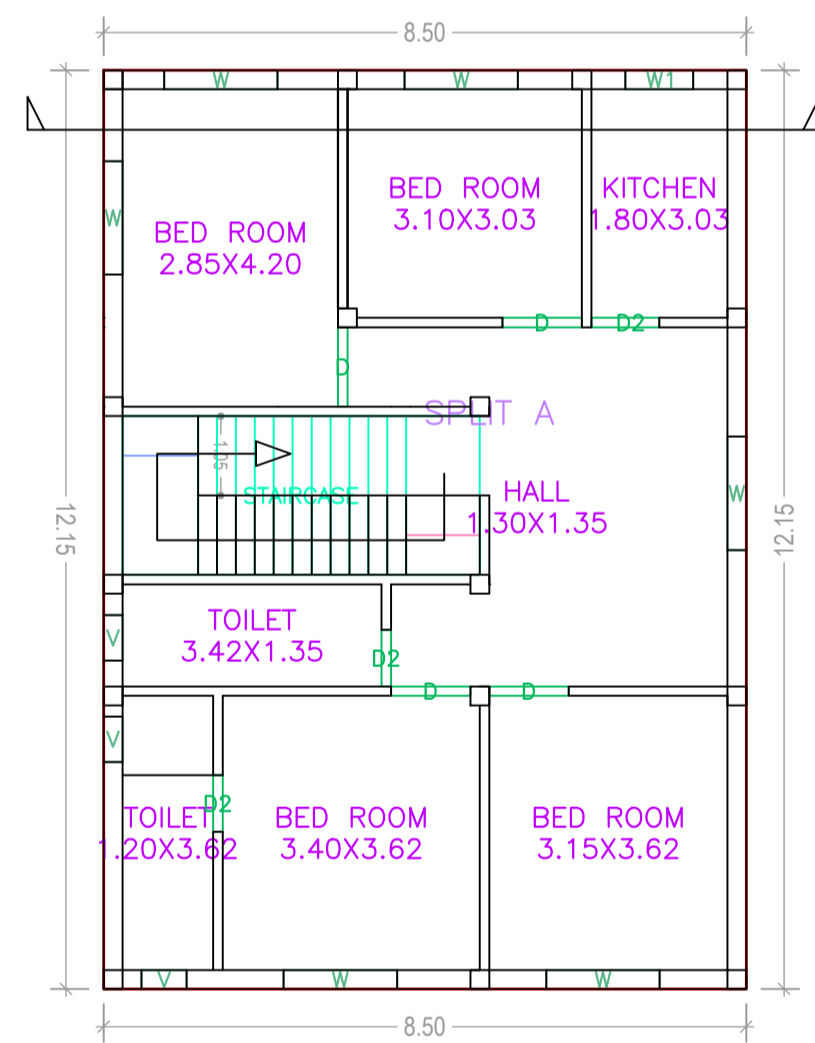

FIRST FLOOR PLAN (Proposed) (SCALE 1:100)

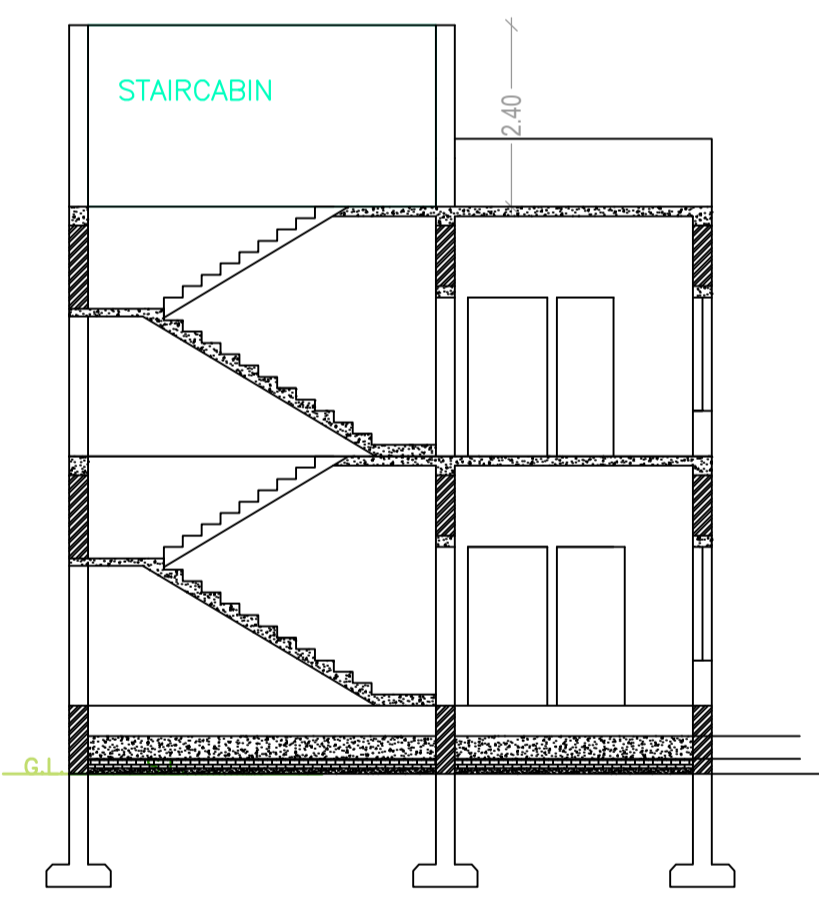

CROSS SECTION (A)

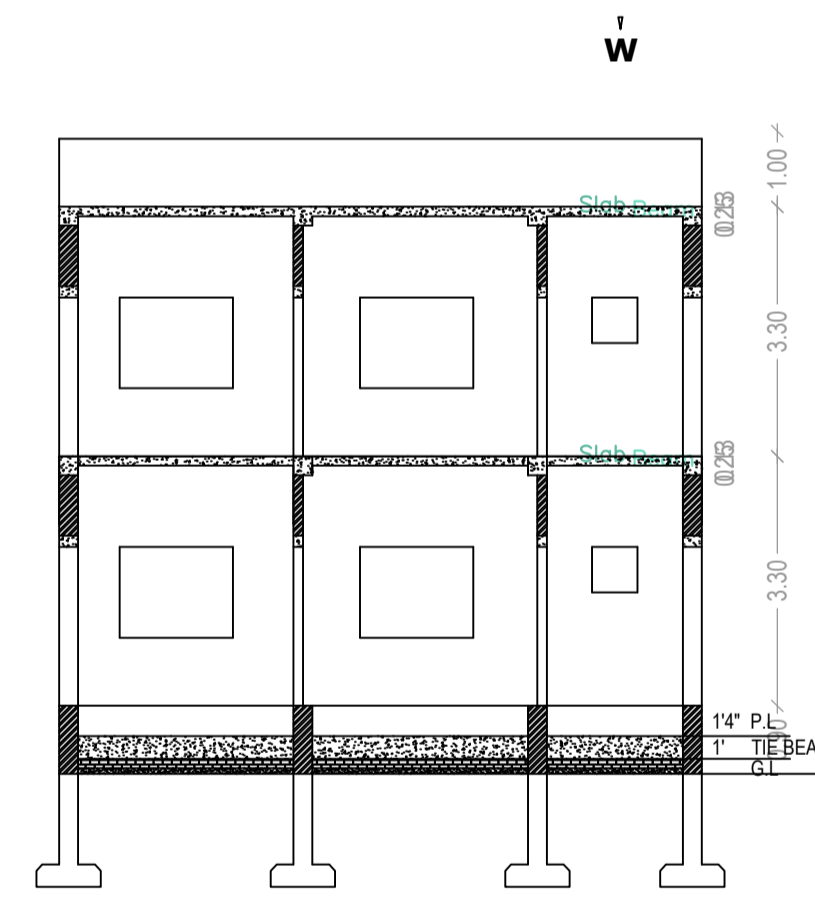

CROSS SECTION (B)

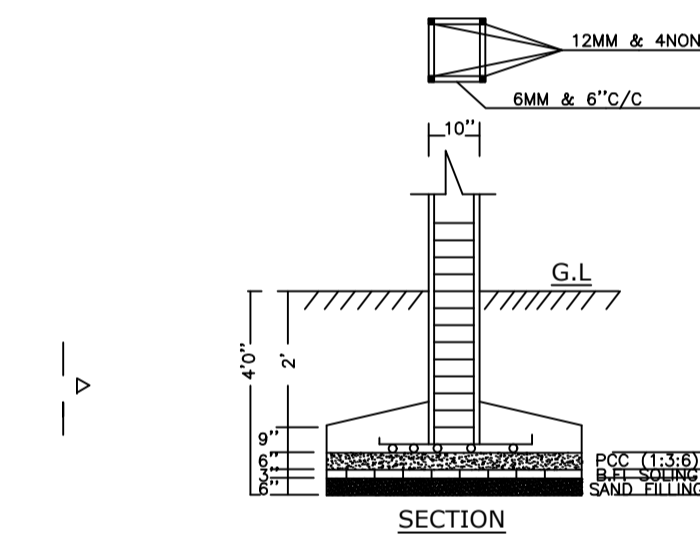

SECTION

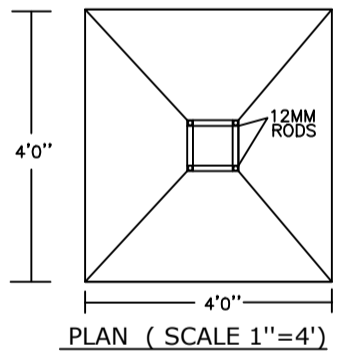

PLAN (SCALE 1\"/>

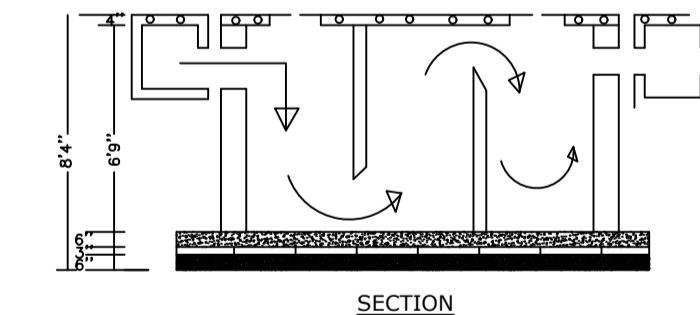

SECTION

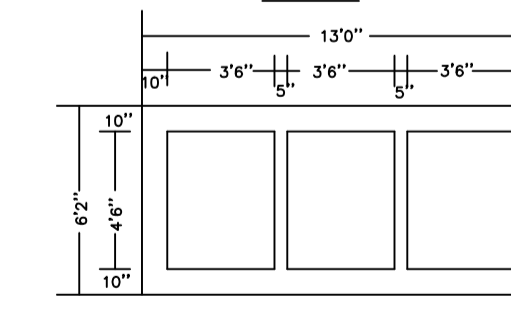

PLAN OF SEPTIC TANK

COLOR INDEX

PLOT BOUNDARY	Black
ABUTTING ROAD	Green
PROPOSED CONSTRUCTION	Red
COMMON PLOT	Yellow
ROAD WIDENING AREA	Blue
EXISTING (To be retained)	Light Blue
EXISTING (To be demolished)	Dark Blue

Buildingwise Floor FAR Details

Floor Name	Building Name A (RESIDENTIAL)		Total	
	Proposed Built Up Area (Sq.mt.)	Proposed FAR Area (Sq.mt.)	Total Proposed Built Up Area (Sq.mt.)	Total FAR Area (Sq.mt.)
Ground Floor	103.27	103.27	103.27	103.27
First Floor	103.27	103.27	103.27	103.27
Terrace Floor	0.00	0.00	0.00	0.00
Total :	206.54	206.54	206.54	206.54

Building USE/SUBUSE Details

Building Name	Building Use	Building SubUse	Building Structure
A (RESIDENTIAL)	Residential	Bungalow/ Dwelling / Non Apartment	Non-Highrise

Building :A (RESIDENTIAL)

Floor Name	Total Built Up Area (Sq.mt.)	Proposed FAR Area (Sq.mt.) Resi.	Total FAR Area (Sq.mt.)	Total Consumed Additional FAR Area (Sq.mt.)	Tnmt (No.)
Ground Floor	103.27	103.27	103.27	103.27	01
First Floor	103.27	103.27	103.27	103.27	00
Terrace Floor	0.00	0.00	0.00	0.00	00
Total :	206.54	206.54	206.54	206.54	01
Total Number of Same Buildings	1				
Total :	206.54	206.54	206.54	206.54	01

SCHEDULE OF DOOR:

BUILDING NAME	NAME	LENGTH	HEIGHT	NOS
A (RESIDENTIAL)	D2	0.75	2.10	02
A (RESIDENTIAL)	D2	0.90	2.10	02
A (RESIDENTIAL)	D	1.05	2.10	07

SCHEDULE OF WINDOW/VENTILATION:

BUILDING NAME	NAME	LENGTH	HEIGHT	NOS
A (RESIDENTIAL)	V	0.60	0.90	04
A (RESIDENTIAL)	W1	0.90	1.20	01
A (RESIDENTIAL)	W	1.50	1.20	10

UnitBUA Table for Building :A (RESIDENTIAL)

FLOOR	Name	UnitBUA Type	UnitBUA Area	Carpet Area	No. of Rooms	No. of Tenement
GROUND FLOOR PLAN	SPLIT A	FLAT	122.41	121.69	4	1
FIRST FLOOR PLAN	SPLIT A	FLAT	0.00	0.00	8	0
Total:	-	-	122.41	121.69	12	1

LTP NAME AND SIGNATURE	STRUCTURAL ENG'S NAME AND SIGNATURE	BUILDER NAME AND SIGNATURE	DIGITAL SIGNATURE
KIRAN KUMARI JNP/ENG/0001/2019			