

SITE PLAN

FAR & Tenement Details (Table 4c-1)

Building	No. of Same Bldg	Total Built Up Area (Sq.mt.)	Proposed FAR Area (Sq.mt.) Resi.	Total FAR Area (Sq.mt.)	Total Consumed Additional FAR Area (Sq.mt.)	Tnmt (No.)
A (RESIDENTIAL)	1	79.64	79.64	79.64	79.64	01
Grand Total :	1	79.64	79.64	79.64	79.64	01

Proposal Basic Information

Proposal File No.	JNP/BI/0073/W/12/2019
Owner Name	SRI ANIL PRASAD BARNWAL SRI ASHOK PRASAD BARNWAL
Khata No	1133
Plot No	7232
Village Name	Tilaiya
Use	Residential
SubUse	Bungalow/ Dwelling / Non Apartment

AREA STATEMENT	VERSION NO. : 1.0.46
JHUMRITILAIYA NAGAR PARISHAD	VERSION DATE: 22/06/2020
PROJECT DETAIL:	
Region : JHARKHAND URBAN LOCAL BODIES	Plot Use: Residential
District : KODERMA	Plot SubUse: Bungalow/ Dwelling / Non Apartment
Authority : JHUMRITILAIYA NAGAR PARISHAD	PlotNearbyReligiousStructure: NA
Inward No : JNP/BI/0073/W/12/2019	Plot/SubPlot No: 7232
Application Type: General Proposal	North: Plot No - SRI MAHAVEER SAW
Project Type: Building Permission	South: Plot No - SRI JAGDISH RAM
Nature of Development: New	East: Plot No - SRI GURUDEO LOHANI
Location of Development Area: Old Area	West: Road Width - 3.65
AREA DETAILS:	SQ. MT.
AREA OF PLOT (Minimum)	(A) 69.72
NET AREA OF PLOT(Gross Plot Area - Deduction from Gross Plot area)	(A-Deductions) 69.72
Deduction for Balance Plot Area(from Gross Plot Area)	
Common Plot	10.12
Total	10.12
BALANCE AREA OF PLOT(Net Plot Area - Recreational/Amenity space)	(A-Deductions) 59.59
PLOT AREA FOR COVERAGE(Net Plot Area)	(A-Deductions) 69.72
Plot Area for FAR (Net Plot Area + RoadWidening Area)	(A-Deductions) 69.72
COVERAGE CHECK	
Permissible Coverage area ( 70.00 % )	48.80
Proposed Coverage Area ( 57.12 % )	39.82
Total Prop. Coverage Area ( 57.12 % )	39.82
Balance coverage area ( 12.88 % )	8.98
FAR CHECK	
Perm. FAR Area ( 1.50 )	104.58
Total Perm. FAR area	104.58
Residential FAR	79.64
Proposed FAR Area	79.64
Total Proposed FAR Area	79.64
Consumed FAR (Factor)	1.14
Balance FAR Area	24.94
BUILT UP AREA CHECK	
Total Proposed BuiltUp Area	79.64
ARCHITECT (Regd)	KIRAN KUMARI
ENGINEER (Regd)	
SUPERVISOR (Regd)	
OWNER (Regd)	SRI ANIL PRASAD BARNWAL SRI ASHOK PRASAD BARNWAL
DEVELOPMENT AUTHORITY	LOCAL BODY

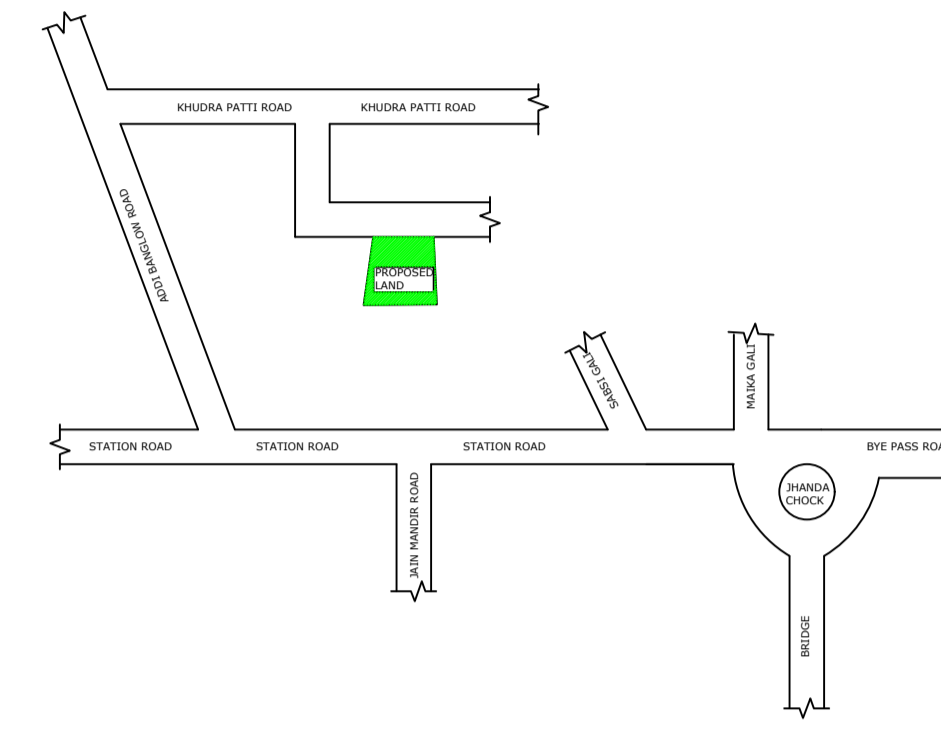

LOCATION PLAN (SCALE -1''16')

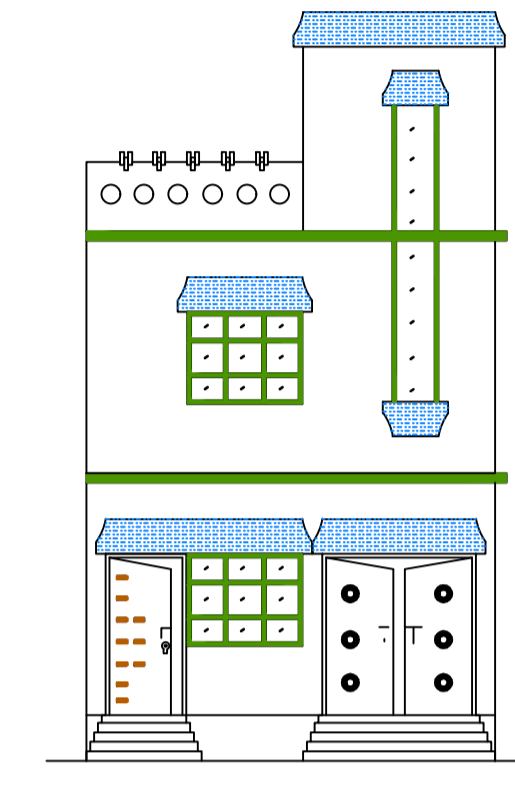

FRONT ELEVATION

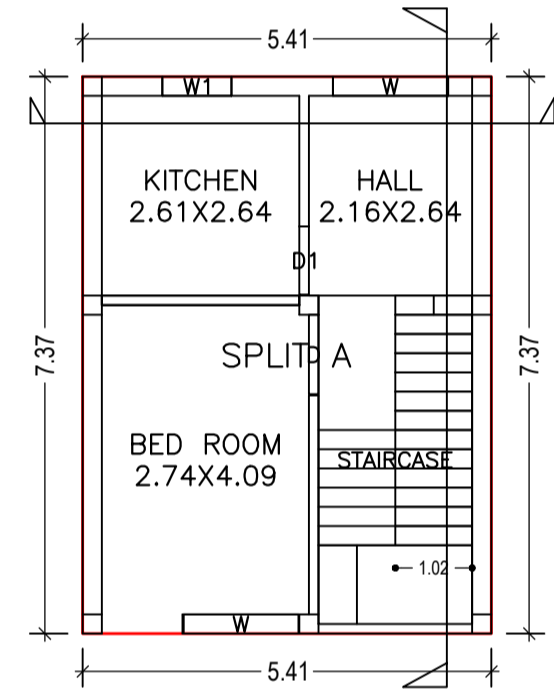

GROUND FLOOR PLAN (Proposed) (SCALE 1:100)

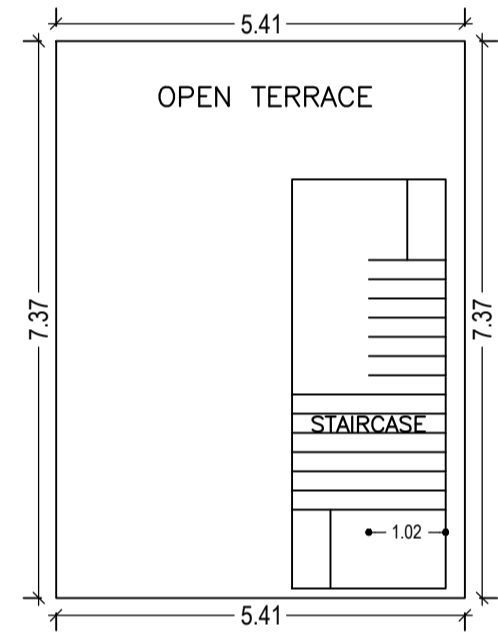

TERRACE FLOOR PLAN (SCALE 1:100)

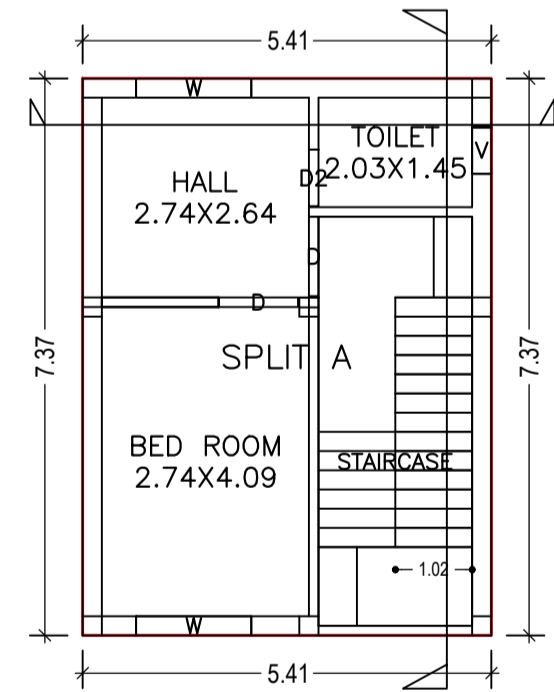

FIRST FLOOR PLAN (Proposed) (SCALE 1:100)

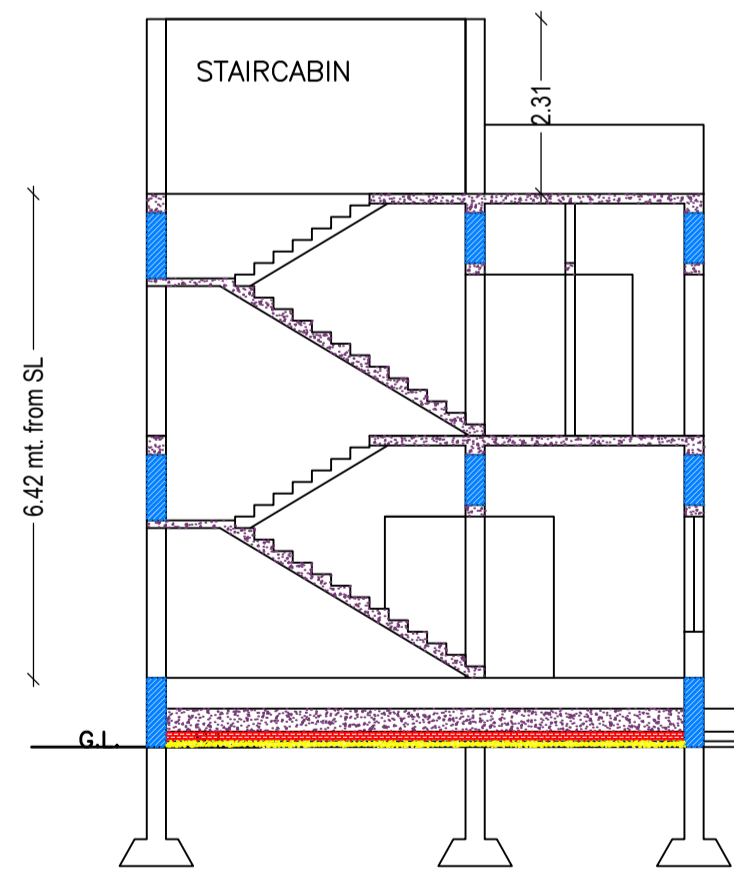

CROSS SECTION (A)

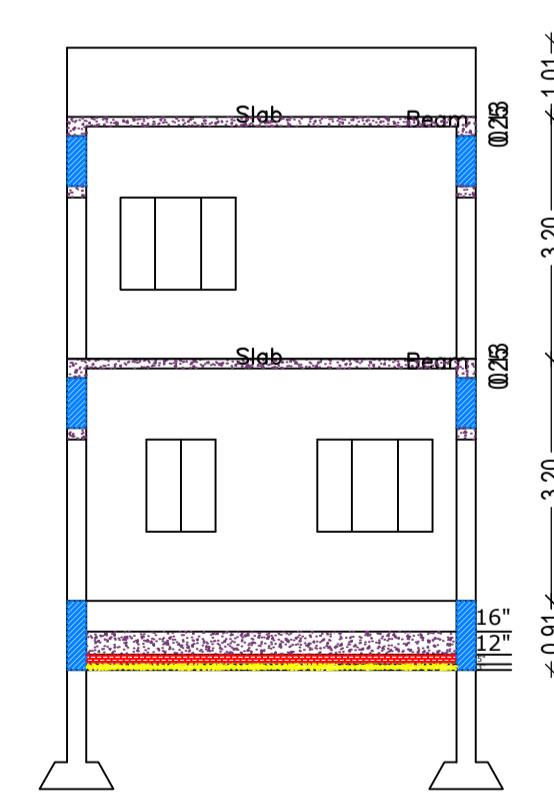

CROSS SECTION (B)

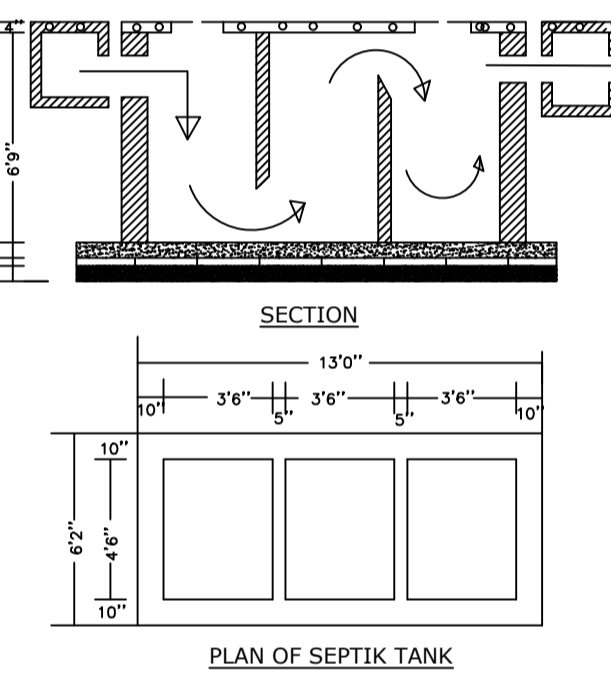
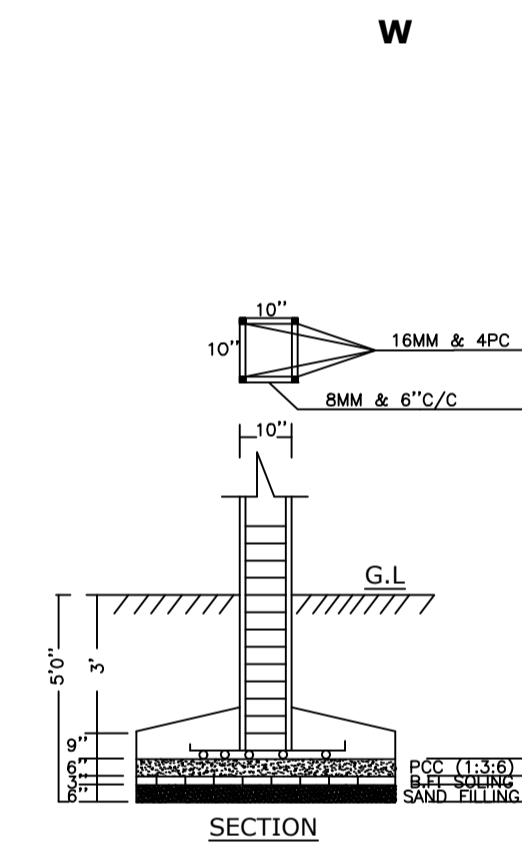

PLAN OF SEPTIC TANK

COLOR INDEX	
PLOT BOUNDARY	[Red Line]
ABUTTING ROAD	[Green Line]
PROPOSED CONSTRUCTION	[Yellow Line]
COMMON PLOT	[Blue Line]
ROAD WIDENING AREA	[Orange Line]
EXISTING (To be retained)	[Black Line]
EXISTING (To be demolished)	[White Line]

Buildingwise Floor FAR Details

Floor Name	Building Name A (RESIDENTIAL)		Total	
	Proposed Built Up Area (Sq.mt.)	Proposed FAR Area (Sq.mt.)	Total Proposed Built Up Area (Sq.mt.)	Total FAR Area (Sq.mt.)
Ground Floor	39.82	39.82	39.82	39.82
First Floor	39.82	39.82	39.82	39.82
Terrace Floor	0.00	0.00	0.00	0.00
Total :	79.64	79.64	79.64	79.64

Building USE/SUBUSE Details

Building Name	Building Use	Building SubUse	Building Structure
A (RESIDENTIAL)	Residential	Bungalow/ Dwelling / Non Apartment	Non-Highrise

Building :A (RESIDENTIAL)

Floor Name	Total Built Up Area (Sq.mt.)	Proposed FAR Area (Sq.mt.) Resi.	Total FAR Area (Sq.mt.)	Total Consumed Additional FAR Area (Sq.mt.)	Tnmt (No.)
Ground Floor	39.82	39.82	39.82	39.82	01
First Floor	39.82	39.82	39.82	39.82	00
Terrace Floor	0.00	0.00	0.00	0.00	00
Total :	79.64	79.64	79.64	79.64	01
Total Number of Same Buildings	1				
Total :	79.64	79.64	79.64	79.64	01

SCHEDULE OF DOOR:

BUILDING NAME	NAME	LENGTH	HEIGHT	NOS
A (RESIDENTIAL)	D2	0.75	2.10	01
A (RESIDENTIAL)	D1	0.90	2.10	01
A (RESIDENTIAL)	D	1.05	2.10	03

SCHEDULE OF WINDOW/VENTILATION:

BUILDING NAME	NAME	LENGTH	HEIGHT	NOS
A (RESIDENTIAL)	V	0.62	0.90	01
A (RESIDENTIAL)	W1	0.91	1.20	01
A (RESIDENTIAL)	W	1.52	1.20	04

UnitBUA Table for Building :A (RESIDENTIAL)

FLOOR	Name	UnitBUA Type	UnitBUA Area	Carpet Area	No. of Rooms	No. of Tenement
GROUND FLOOR PLAN	SPLIT A	FLAT	46.39	45.87	3	1
FIRST FLOOR PLAN	SPLIT A	FLAT	0.00	0.00	3	0
Total:	-	-	46.39	45.87	6	1

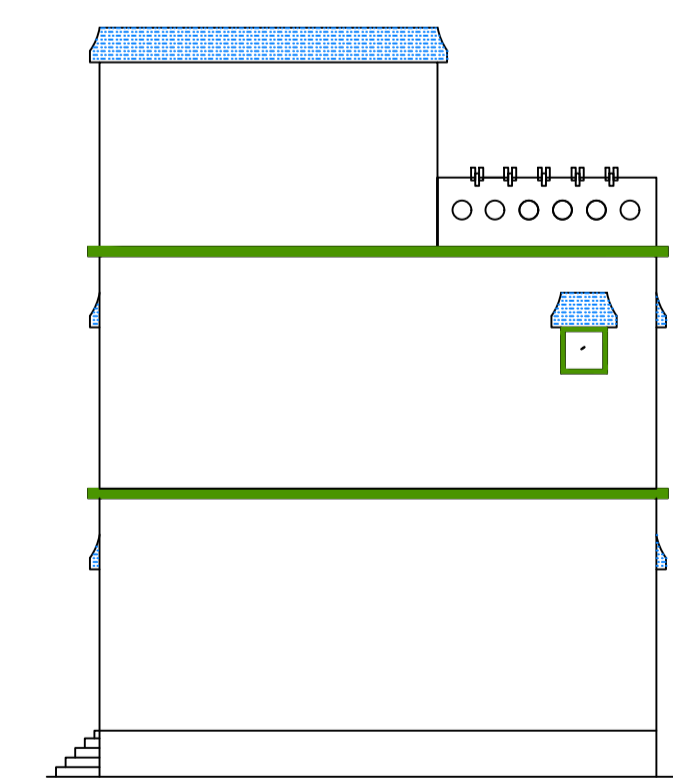

CROSS ELEVATION

LTP NAME AND SIGNATURE	STRUCTURAL ENG'S NAME AND SIGNATURE	BUILDER NAME AND SIGNATURE	DIGITAL SIGNATURE
KIRAN KUMARI JNP/ENG/0001/2019			