

FAR & Tenement Details (Table 4c-1)

Building	No. of Same Bldg	Total Built Up Area (Sq.mt.)	Proposed FAR Area (Sq.mt.) Resi.	Total FAR Area (Sq.mt.)	Total Consumed Additional FAR Area (Sq.mt.)	Tnmt (No.)
A (NITESH KUMAR SINGH)	1	158.82	158.82	158.82	158.82	01
Grand Total :	1	158.82	158.82	158.82	158.82	01

Proposal Basic Information

Proposal File No.	JNP/BP/0005/W22/2019
Owner Name	NITESH KUMAR SINGH
Khata No	618
Plot No	5653
Village Name	Gomo
Use	Residential
SubUse	Residential Bldg/Apartment

AREA STATEMENT	VERSION NO. : 1.0.33	
JHUMRITILAIYA NAGAR PARISHAD		
PROJECT DETAIL:		
Region: JHARKHAND URBAN LOCAL BODIES	Plot Use: Residential	
District: KODERMA	Plot SubUse: Residential Bldg/Apartment	
Authority: JHUMRITILAIYA NAGAR PARISHAD	PlotNearbyReligiousStructure: NA	
Inward No: JNP/BP/0005/W22/2019	Plot/SubPlot No: 5653	
Application Type: General Proposal		
Project Type: Building Permission	South: Plot No. - HOUSE OF MAHESHWAR RAM	
Nature of Development: New	East: Plot No. - LAND OF NITESH KUMAR SINGH	
Location of Development Area: Old Area	West: Plot No. - LAND OF DINESHWAR YADAV	
AREA DETAILS:		SQ.MT.
AREA OF PLOT (Minimum)	(A)	120.87
NET AREA OF PLOT(Gross Plot Area - Deduction from Gross Plot area)	(A-Deductions)	120.87
Deduction for Balance Plot Area(from Gross Plot Area)		
Common Plot		15.80
Total		15.80
BALANCE AREA OF PLOT(Net Plot Area - Recreational/Amenity space)	(A-Deductions)	105.07
PLOT AREA FOR COVERAGE(Net Plot Area)	(A-Deductions)	120.87
Plot Area for FAR (Net Plot Area + RoadWidening Area)	(A-Deductions)	120.87
COVERAGE CHECK		
Permissible Coverage area (70.00 %)		84.61
Proposed Coverage Area (65.70 %)		79.41
Total Prop. Coverage Area (65.7 %)		79.41
Balance coverage area (4.30 %)		5.20
FAR CHECK		
Perm. FAR Area (1.50)		181.31
Total Perm. FAR area		181.31
Residential FAR		158.83
Proposed FAR Area		158.83
Total Proposed FAR Area		158.83
Consumed FAR (Factor)		1.31
Balance FAR Area		22.48
BUILT UP AREA CHECK		
Total Proposed BuiltUp Area		158.82
ARCHITECT (Regd)	UPENDRA	
ENGINEER (Regd)		
SUPERVISOR (Regd)		
OWNER (Regd)	NITESH KUMAR SINGH	
DEVELOPMENT AUTHORITY	LOCAL BODY	

COLOR INDEX	
PLOT BOUNDARY	Black
ABUTTING ROAD	Green
PROPOSED CONSTRUCTION	Red
COMMON PLOT	Yellow
ROAD WIDENING AREA	Blue
EXISTING (To be retained)	Blue
EXISTING (To be demolished)	Yellow

Buildingwise Floor FAR Details

Floor Name	Building Name		Total	
	Proposed Built Up Area (Sq.mt.)	Proposed FAR Area (Sq.mt.)	Total Proposed Built Up Area (Sq.mt.)	Total FAR Area (Sq.mt.)
Ground Floor	79.41	79.41	79.41	79.41
First Floor	79.41	79.41	79.41	79.41
Terrace Floor	0.00	0.00	0.00	0.00
Total :	158.82	158.82	158.82	158.82

Building USE/SUBUSE Details

Building Name	Building Use	Building SubUse	Building Structure
A (NITESH KUMAR SINGH)	Residential	Bungalow/ Dwelling / Non Apartment	Non-Highrise

LTP NAME AND SIGNATURE	STRUCTURAL ENG'S NAME AND SIGNATURE	BUILDER NAME AND SIGNATURE	DIGITAL SIGNATURE
UPENDRA JNP/ENG/0012/2017			

Proposal Basic Information	
Proposal File No.	JNP/EP/0005/W22/2019
Owner Name	NITESH KUMAR SINGH
Khata No	618
Plot No	5653
Village Name	Gomo
Use	Residential
SubUse	Residential Bldg/Apartment

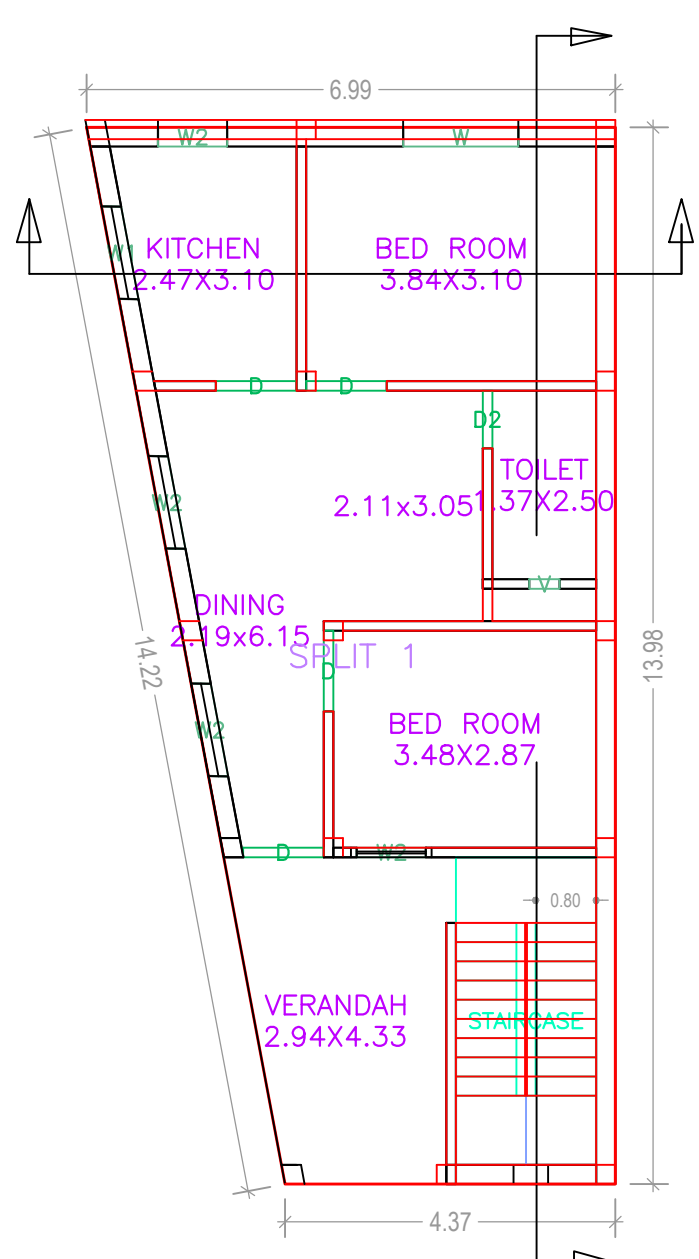

GROUND FLOOR PLAN (Proposed) (SCALE 1:100)

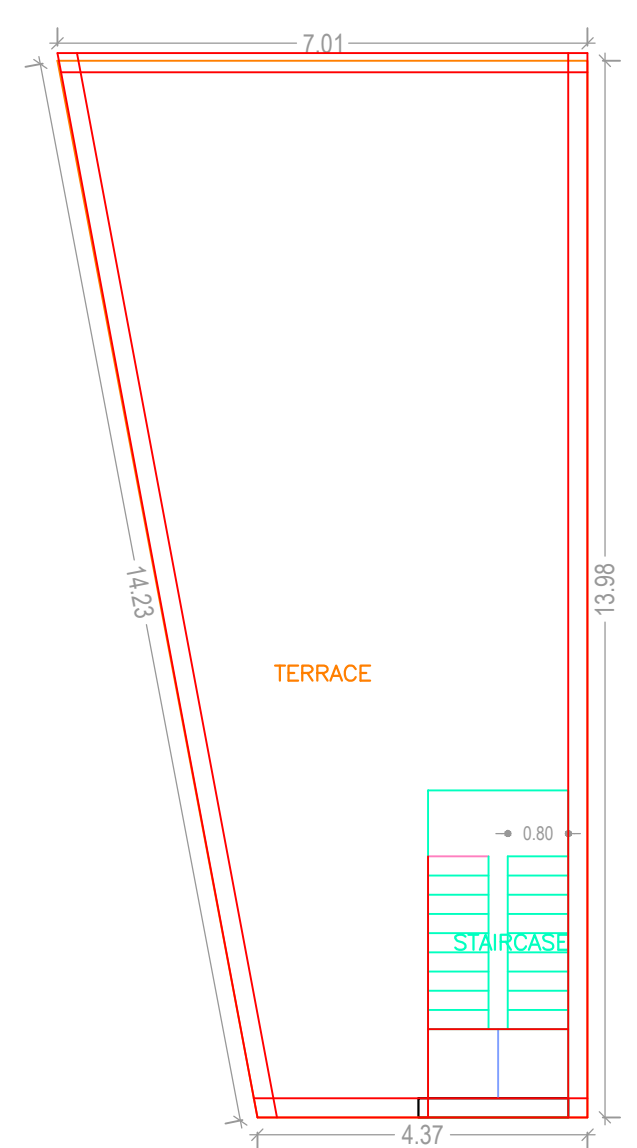

TERRACE FLOOR PLAN (SCALE 1:100)

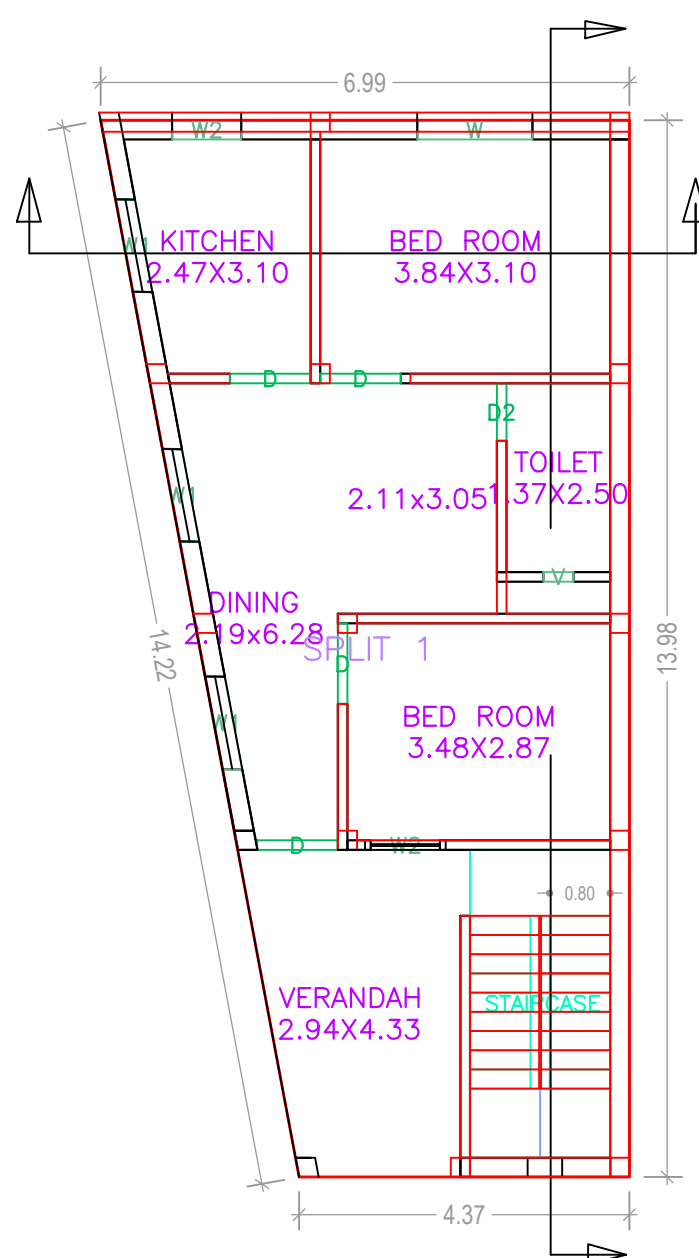

FIRST FLOOR PLAN (Proposed) (SCALE 1:100)

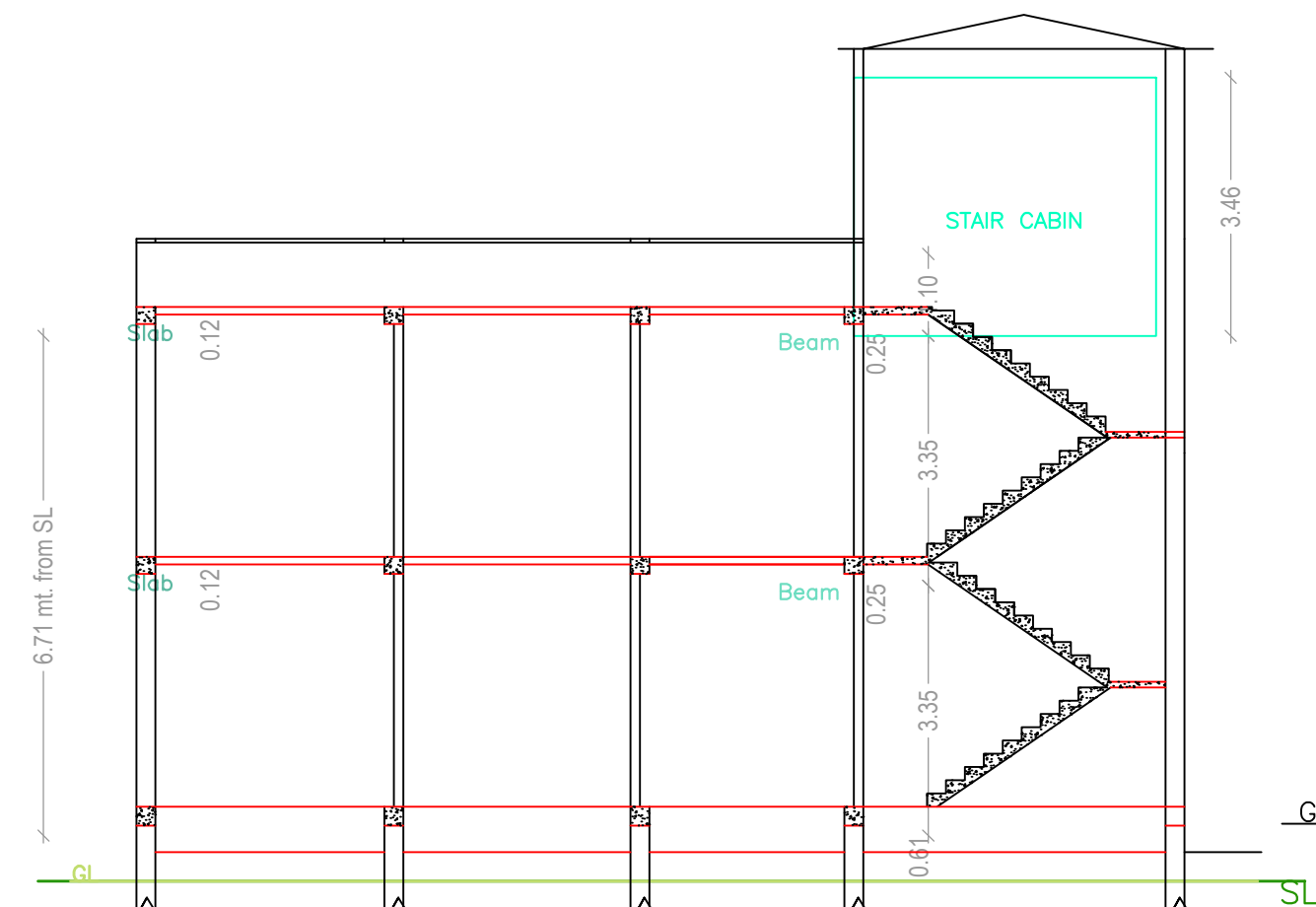

CROSS SECTION (X-Y)

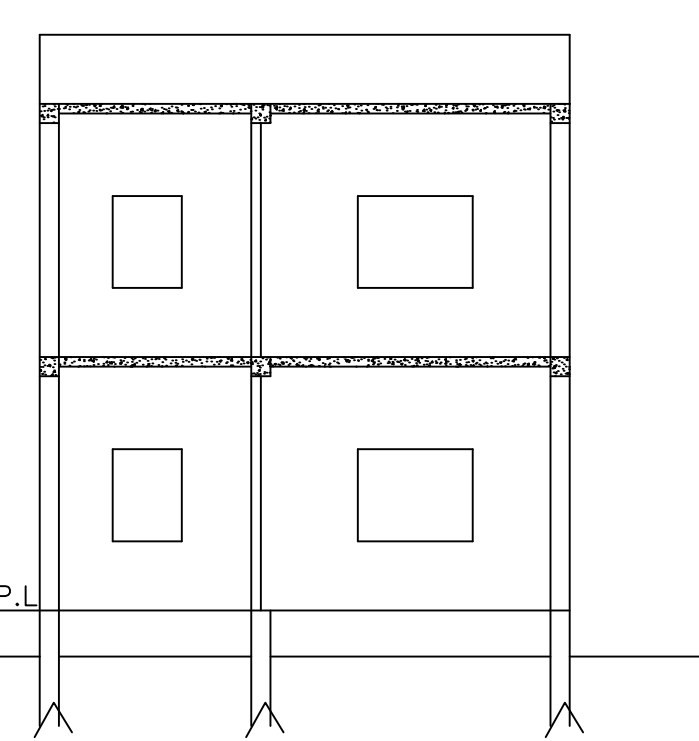

CROSS SECTION (A-B)

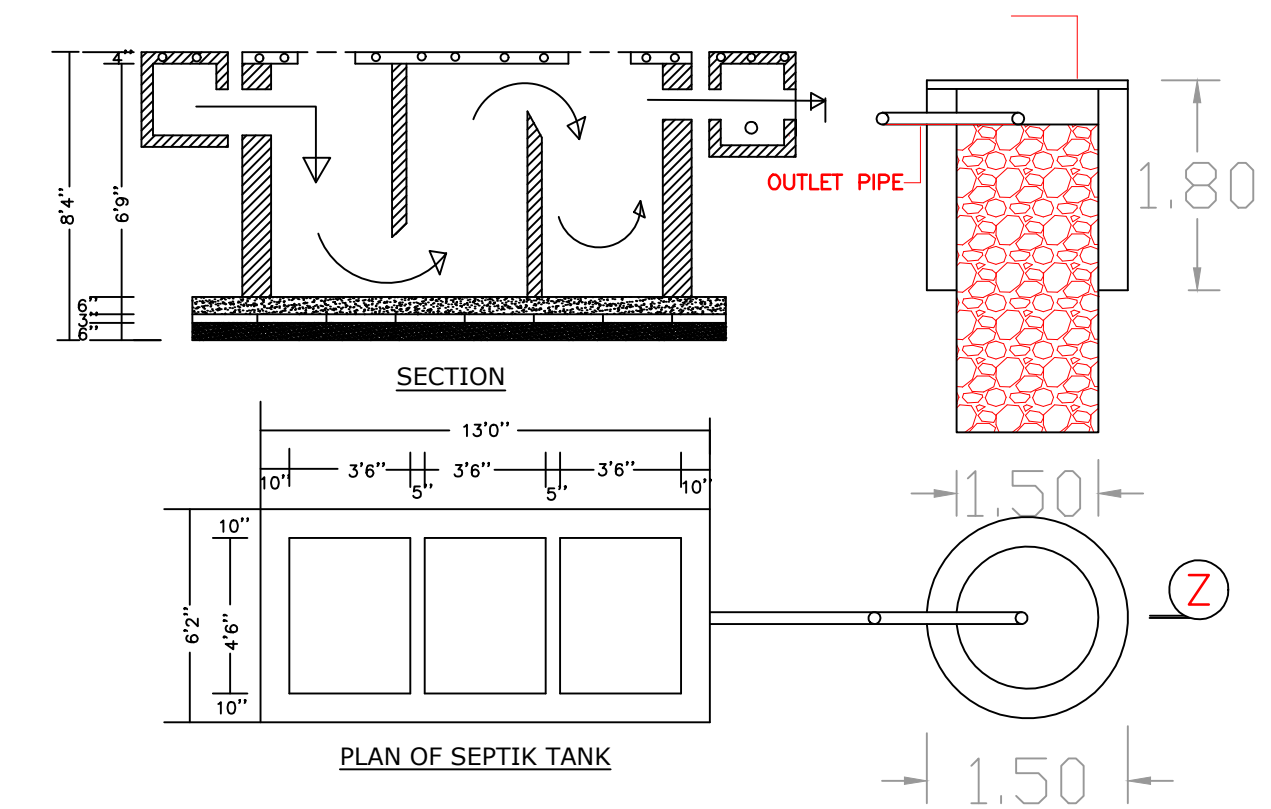
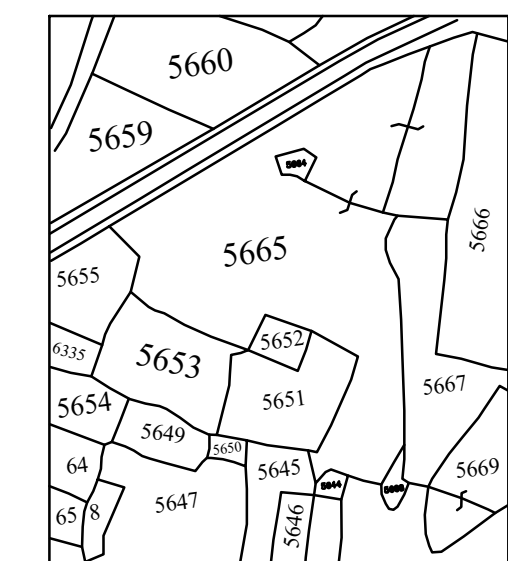

PLAN OF SEPTIK TANK

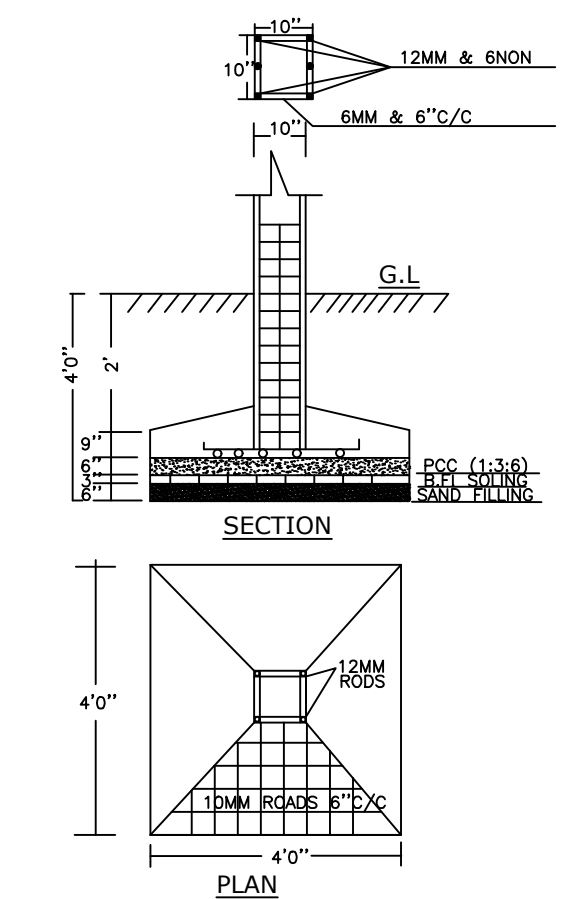
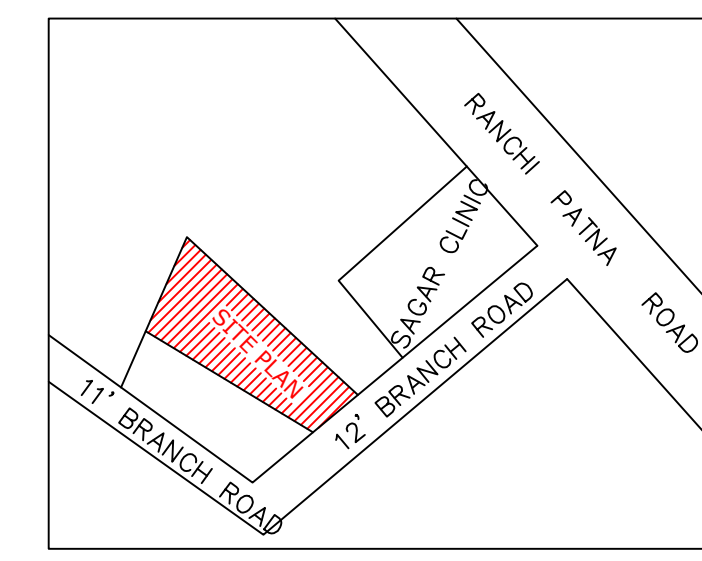

PLAN

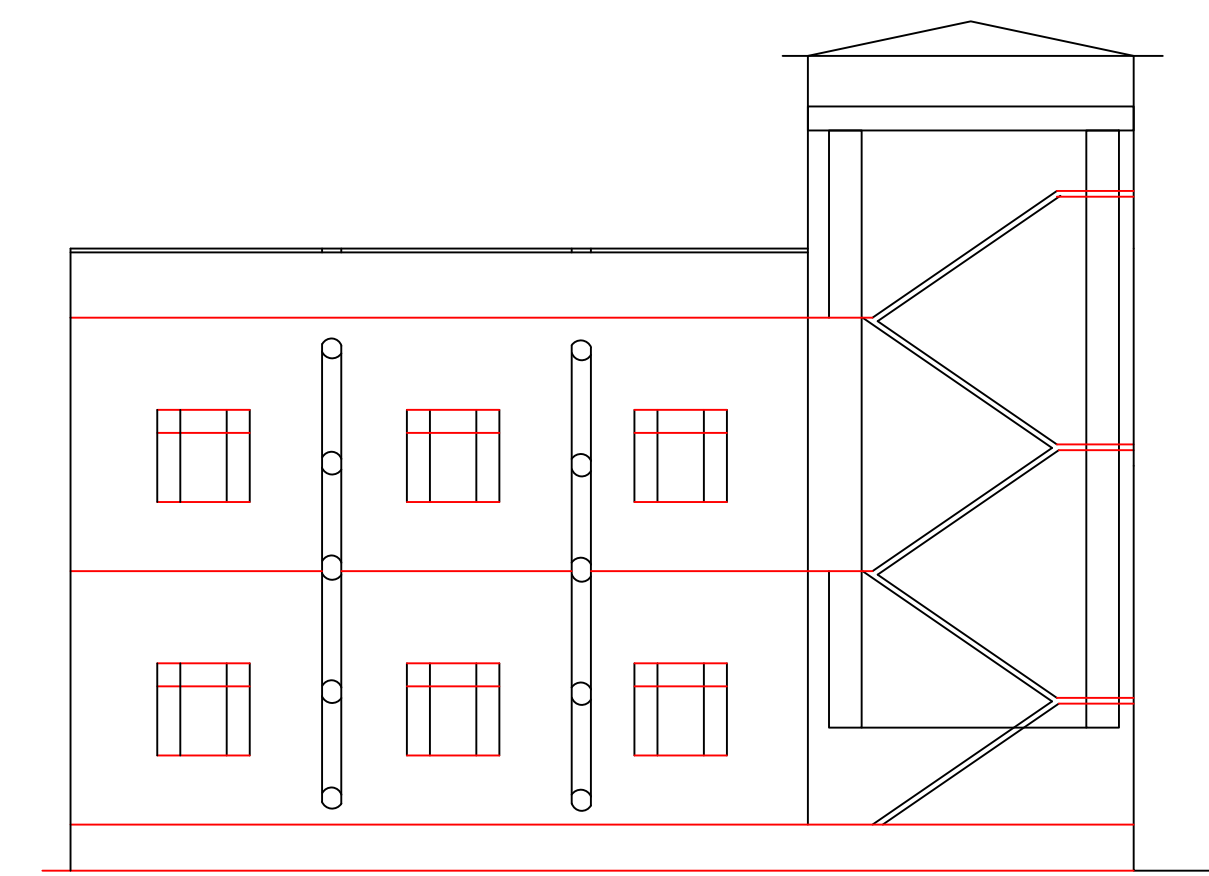

FRONT ELEVATION (LEFT SIDE)

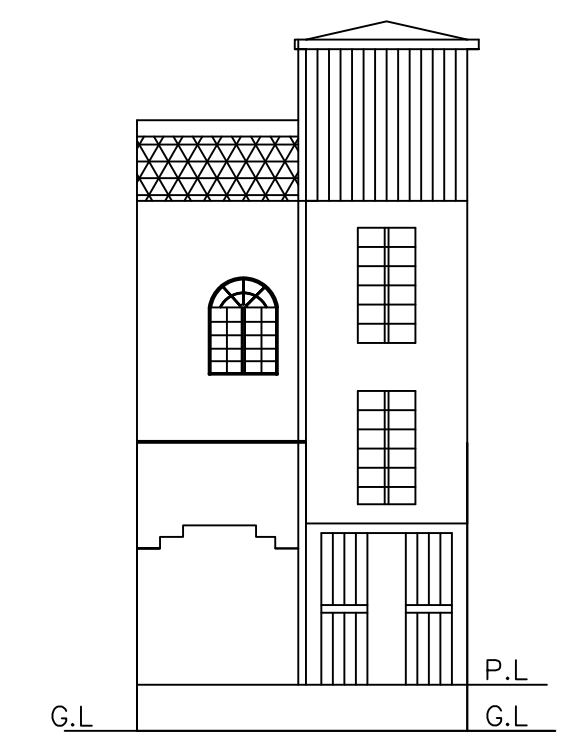

FRONT ELEVATION

Building :A (NITESH KUMAR SINGH)

Floor Name	Total Built Up Area (Sq.mt.)	Proposed FAR Area (Sq.mt.)	Total FAR Area (Sq.mt.)	Total Consumed Additional FAR Area (Sq.mt.)	Tnmt (No.)
Ground Floor	79.41	79.41	79.41	79.41	01
First Floor	79.41	79.41	79.41	79.41	00
Terrace Floor	0.00	0.00	0.00	0.00	00
Total:	158.82	158.82	158.82	158.82	01
Total Number of Same Buildings	1				
Total:	158.82	158.82	158.82	158.82	01

SCHEDULE OF DOOR:

BUILDING NAME	NAME	LENGTH	HEIGHT	NOS
A (NITESH KUMAR SINGH)	D2	0.76	2.10	02
A (NITESH KUMAR SINGH)	D	1.07	2.10	08

SCHEDULE OF WINDOW/VENTILATION:

BUILDING NAME	NAME	LENGTH	HEIGHT	NOS
A (NITESH KUMAR SINGH)	V	0.40	1.20	02
A (NITESH KUMAR SINGH)	W2	0.91	1.20	04
A (NITESH KUMAR SINGH)	W1	1.25	1.20	04
A (NITESH KUMAR SINGH)	W2	1.25	1.20	02
A (NITESH KUMAR SINGH)	W	1.52	1.20	02

UnitBUA Table for Building :A (NITESH KUMAR SINGH)

FLOOR	Name	UnitBUA Type	UnitBUA Area	Carpet Area	No. of Rooms	No. of Tenement
GROUND FLOOR PLAN	SPLIT 1	FLAT	158.83	140.19	6	1
FIRST FLOOR PLAN	SPLIT 1	FLAT	0.00	0.00	6	0
Total:	-	-	158.83	140.19	12	1

LTP NAME AND SIGNATURE	STRUCTURAL ENG'S NAME AND SIGNATURE	BUILDER NAME AND SIGNATURE	DIGITAL SIGNATURE
UPENDRA JNP/ENG/0012/2017			