

Project Title :
PROPOSED BUILDING PLAN FOR:- SMT SHEELA SINHA .W/O - SRI BINOD PD SINHA . MAUZA-MORIYAWAN. WARD NO- 08. P.S-TELAIIYA.P.S NO- 02
KHATA NO:- 33 .PLOT NO:-170 (P) .DISTT- KODERMA (JHARAKHAND)

PROPOSED BUILDING PLAN FOR:- SMT SHEELA SINHA .W/O - SRI BINOD PD SINHA . MAUZA-MORIYAWAN. WARD NO- 08. P.S-TELAIIYA.P.S NO- 02
. KHATA NO:- 33 .PLOT NO:-170 (P) .DISTT- KODERMA (JHARAKHAND)

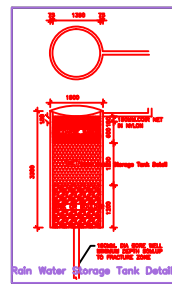
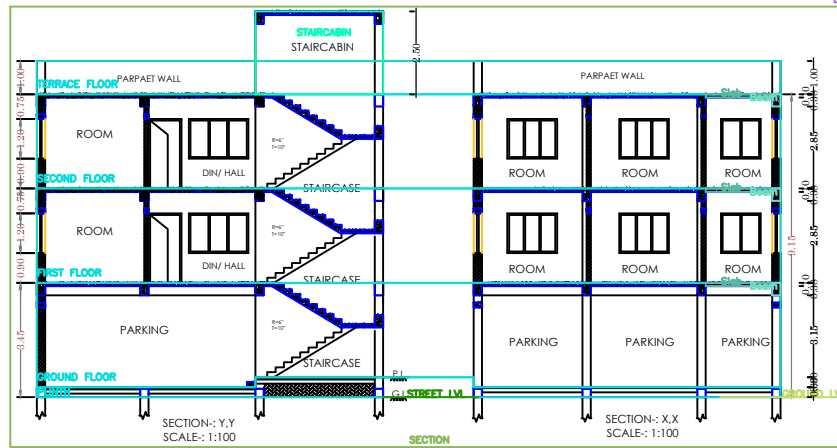
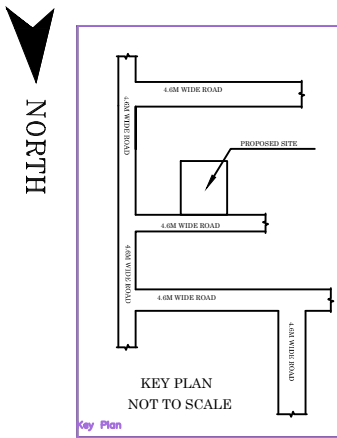
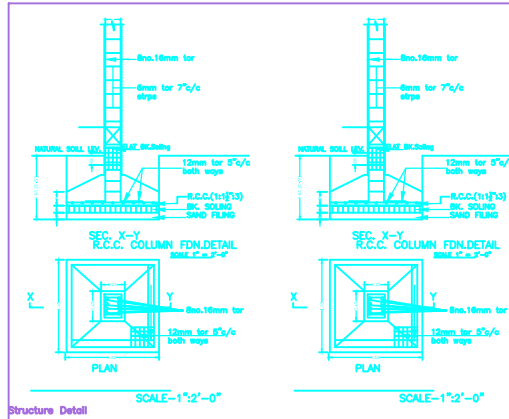
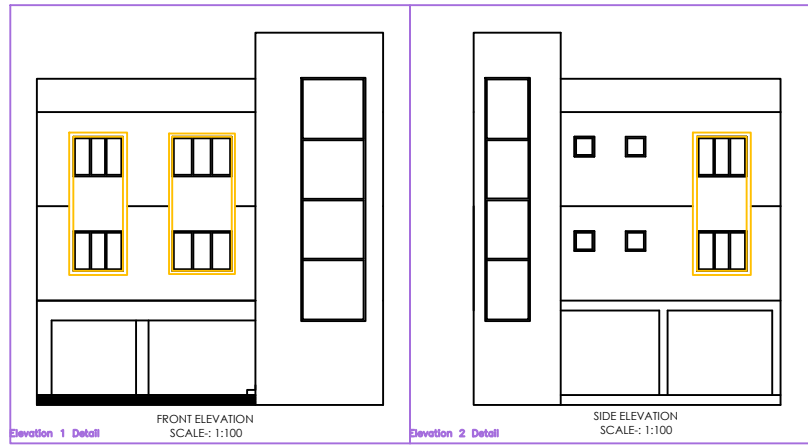

W.H.T -WATER HARVESTING TANK.
S.T -SEPTIC TANK.

NORTH- 4.6M WIDE ROAD
SOUTH - OWN LAND
EAST - OWN LAND
WEST - LAND OF SMT CHANDRALATA BARNWAL

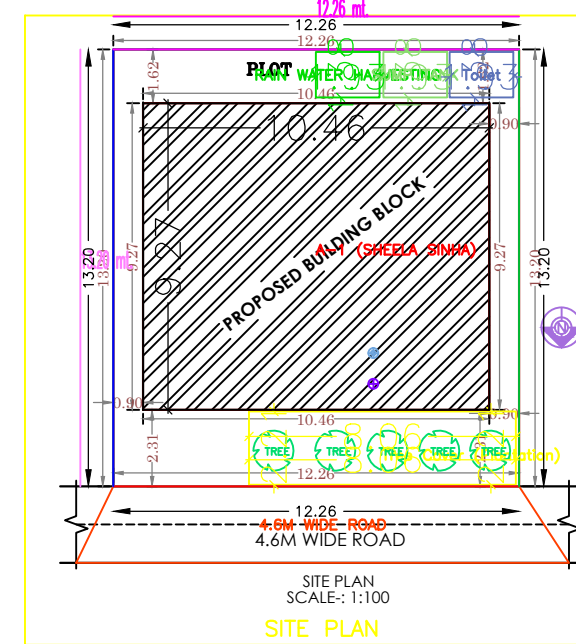
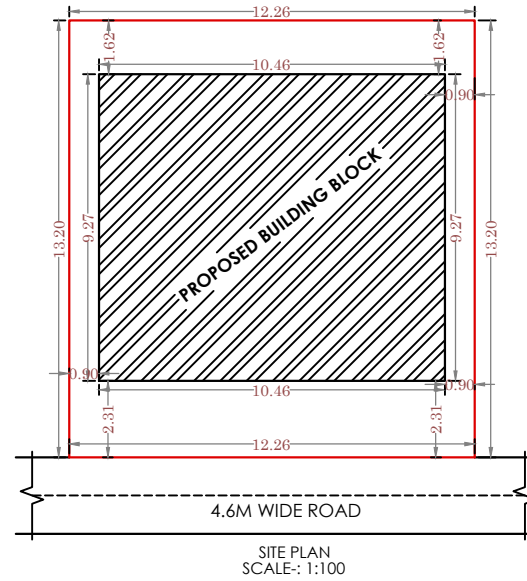
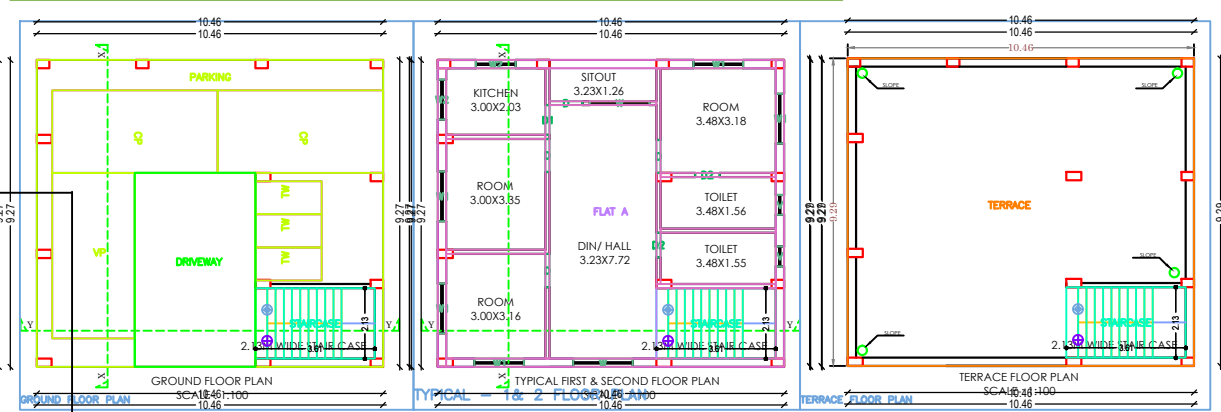
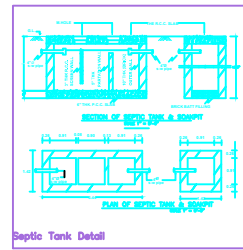

Building :A (SHEELA SINHA)

Floor Name	Total Built Up Area (Sq.mt.)	Deductions (Area in Sq.mt.)	Proposed FAR Area (Sq.mt.)	Add Area In FAR (Sq.mt.)	Total FAR Area (Sq.mt.)	Trmt (No.)
Ground Floor	97.04	89.36	0.00	7.68	7.68	00
First Floor	97.04	0.00	97.04	0.00	97.04	01
Second Floor	97.04	0.00	97.04	0.00	97.04	01
Terrace Floor	0.00	0.00	0.00	0.00	0.00	00
Total	291.12	89.36	194.08	7.68	201.76	02
Total Number of Same Buildings	1					
Total	291.12	89.36	194.08	7.68	201.76	02

SCHEDULE OF JOINERY:

BUILDING NAME	NAME	LENGTH	HEIGHT	NOS
A (SHEELA SINHA)	D2	0.75	2.13	04
A (SHEELA SINHA)	D1	0.80	2.13	02
A (SHEELA SINHA)	D	1.00	2.13	08
Total				14

SCHEDULE OF JOINERY:

BUILDING NAME	NAME	LENGTH	HEIGHT	NOS
A (SHEELA SINHA)	V	0.60	1.00	04
A (SHEELA SINHA)	W2	1.20	1.20	04
A (SHEELA SINHA)	W1	1.50	1.20	10
A (SHEELA SINHA)	W	1.80	1.20	04
Total				22

UnitBUA Table for Building :A (SHEELA SINHA)

FLOOR	Name	UnitBUA Type	UnitBUA Area	Carpet Area	No. of Rooms	No. of Tenement
TYPICAL - 1st	FLATA	FLAT	79.74	75.37	8	2
2 FLOOR PLAN						
Total			159.49	150.74	16	2

AREA STATEMENT: JHUMRILAYA NAGAR PARISHAD		VERSION NO: 1.0.17
PROJECT DETAIL:		VERSION DATE: 01/01/2019
Inward No. :-	Plot Use :- Residential	
Region :- JHARKHAND URBAN LOCAL BODIES	Plot SubUse :- Bungalow/ Dwelling / Non Apartment	
District :- KODERMA	Land Use Zone :- NA	
Application Type :- General Proposal	Abutting Road Width :-	
Project Type :- Building Permission	Plot No. :-	
Nature of Development :- New	Revenue Survey No/Survey No :-	
Location :- Old Area	Thana No :-	
Sub Location :- NA	Holding No :-	
Village/Mauza Name :-	Khata No :-	
North :-	South :-	
East :-	West :-	
AREA DETAILS:		SQ.MT.
AREA OF PLOT (Minimum)	(A)	161.93
Net Plot Area (Gross Plot Area - Deductions from Gross Plot Area)	(A-Deductions)	161.93
Deductions for Balance Plot Area (from Gross Plot Area)		
COOP Area		17.82
Total		17.82
Balance Plot Area (Net Plot Area - Recreational/Amenity space)	(A-Deductions)	144.11
Plot Area for Coverage (Net Plot Area)	(A-Deductions)	161.93
Plot Area for FSI (Net Plot Area + Road/Widening Area)	(A-Deductions)	161.93
Accessory/Use Area		2.85
COVERAGE CHECK		
Proposed Coverage Area (59.93 %)		97.04
Total Coverage Area (59.93 %)		97.04
FAR CHECK		
Proposed Area of FAR		201.76
Total Area of FAR		201.76
BUILT UP AREA CHECK		
Total Proposed BuiltUp Area		291.12
ARCH/ ENGG / SUPERVISOR (Regd)		OWNER
DEVELOPMENT AUTHORITY		LOCAL BODY

COLOR INDEX

Color	Meaning
Black	ABUTTING ROAD
Green	PROPOSED WORK (COVERAGE AREA)
Red	EXISTING (To be retained)
Blue	EXISTING (To be demolished)

Color Index:

PARKING CALCULATION:

Parking Type	Prop No.	Prop Area
Car Parking	2	25.00
Two Wheeler Parking	3	6.00
Other Parking	1	45.86
Total Area	6	76.86

MARGIN DETAIL:

Building / Wing Name	Road Name	Front Margin	Rear Margin	Side1 Margin	Side2 Margin
A-1 (SHEELA SINHA)	4.6M WIDE ROAD	2.31	1.62	0.90	0.90

FAR & Tenement Details (Table 4c-1)

Building	No. of Same Bldg	Total Built Up Area (Sq.mt.)	Deductions (Area in Sq.mt.)	Proposed FAR Area (Sq.mt.)	Add Area In FAR (Sq.mt.)	Total FAR Area (Sq.mt.)	Trmt (No.)
A (SHEELA SINHA)	1	291.12	89.36	194.08	7.68	201.76	02
Grand Total	1	291.12	89.36	194.08	7.68	201.76	02