

SITE PLAN

FAR & Tenement Details (Table 4c-1)

Building	No. of Same Bldg	Total Built Up Area (Sq.mt.)	Proposed FAR Area (Sq.mt.) Resi.	Total FAR Area (Sq.mt.)	Total Consumed Additional FAR Area (Sq.mt.)	Tnmt (No.)
A (RESIDENTIAL)	1	156.12	156.12	156.12	156.12	01
Grand Total :	1	156.12	156.12	156.12	156.12	01

Proposal Basic Information

Proposal File No.	JNP/IBP/0034/W16/2019
Owner Name	AMINA KHATOON
Khata No	OLD/NEW-216/988
Plot No	OLD/NEW-1997/7657
Village Name	Tilaiya
Use	Residential
SubUse	Bungalow/ Dwelling / Non Apartment

AREA STATEMENT	VERSION NO. : 1.0.42
JHUMRITILAIYA NAGAR PARISHAD	VERSION DATE: 29/04/2019
PROJECT DETAIL:	
Region: JHARKHAND URBAN LOCAL BODIES	Plot Use: Residential
District: KODERMA	Plot SubUse: Bungalow/ Dwelling / Non Apartment
Authority: JHUMRITILAIYA NAGAR PARISHAD	PlotNearbyReligiousStructure: NA
Inward No: JNP/IBP/0034/W16/2019	Plot/SubPlot No: OLD/NEW-1997/7657
Application Type: General Proposal	North: Road Width - 4.2 MTR
Project Type: Building Permission	South: Plot No. - PLOT NO-7658
Nature of Development: New	East: Plot No. - 1.8 MTR ROAD
Location of Development Area: Old Area	West: Plot No. - BHATU SIDDIQI
AREA DETAILS:	
AREA OF PLOT (Minimum)	(A) 108.56
NET AREA OF PLOT(Gross Plot Area - Deduction from Gross Plot area)	(A-Deductions) 108.56
Deduction for Balance Plot Area(from Gross Plot Area)	
Common Plot	10.98
Total	10.98
BALANCE AREA OF PLOT(Net Plot Area - Recreational/Amenity space)	(A-Deductions) 97.58
PLOT AREA FOR COVERAGE(Net Plot Area)	(A-Deductions) 108.56
Plot Area for FAR (Net Plot Area + Road Widening Area)	(A-Deductions) 108.56
COVERAGE CHECK	
Permissible Coverage area (70.00 %)	75.99
Proposed Coverage Area (54.48 %)	59.15
Total Prop. Coverage Area (54.48 %)	59.15
Balance coverage area (15.51 %)	16.84
FAR CHECK	
Perm. FAR Area (1.50)	162.84
Total Perm. FAR area	162.84
Residential FAR	156.11
Proposed FAR Area	156.11
Total Proposed FAR Area	156.11
Consumed FAR (Factor)	1.44
Balance FAR Area	6.73
BUILT UP AREA CHECK	
Total Proposed BuiltUp Area	156.12
ARCHITECT (Regd)	KIRAN KUMARI
ENGINEER (Regd)	
SUPERVISOR (Regd)	
OWNER (Regd)	AMINA KHATOON
DEVELOPMENT AUTHORITY	LOCAL BODY

COLOR INDEX	
PLOT BOUNDARY	Black
ABUTTING ROAD	Green
PROPOSED CONSTRUCTION	Red
COMMON PLOT	Yellow
ROAD WIDENING AREA	Blue
EXISTING (To be retained)	Blue
EXISTING (To be demolished)	Yellow

Buildingwise Floor FAR Details

Floor Name	Building Name A (RESIDENTIAL)		Total	
	Proposed Built Up Area (Sq.mt.)	Proposed FAR Area (Sq.mt.)	Total Proposed Built Up Area (Sq.mt.)	Total FAR Area (Sq.mt.)
Ground Floor	59.15	59.15	59.15	59.15
First Floor	66.09	66.09	66.09	66.09
Second Floor	30.88	30.88	30.88	30.88
Terrace Floor	0.00	0.00	0.00	0.00
Total :	156.12	156.12	156.12	156.12

Building USE/SUBUSE Details

Building Name	Building Use	Building SubUse	Building Structure
A (RESIDENTIAL)	Residential	Bungalow/ Dwelling / Non Apartment	Non-Highrise

LTP NAME AND SIGNATURE	STRUCTURAL ENG'S NAME AND SIGNATURE	BUILDER NAME AND SIGNATURE	DIGITAL SIGNATURE
KIRAN KUMARI JNP/ENG/0001/2019			

Proposal Basic Information	
Proposal File No.	JNP/EP/0034/W16/2019
Owner Name	AMINA KHATOON
Khata No	OLDNEW-216/988
Plot No	OLDNEW-1997/7657
Village Name	Tilaiya
Use	Residential
SubUse	Bungalow/ Dwelling / Non Apartment

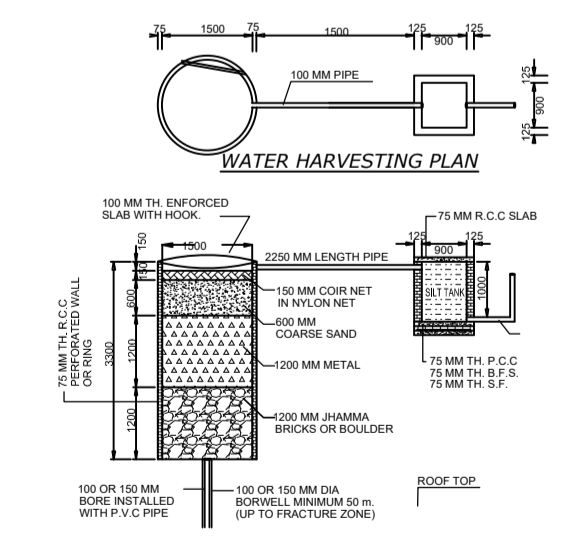
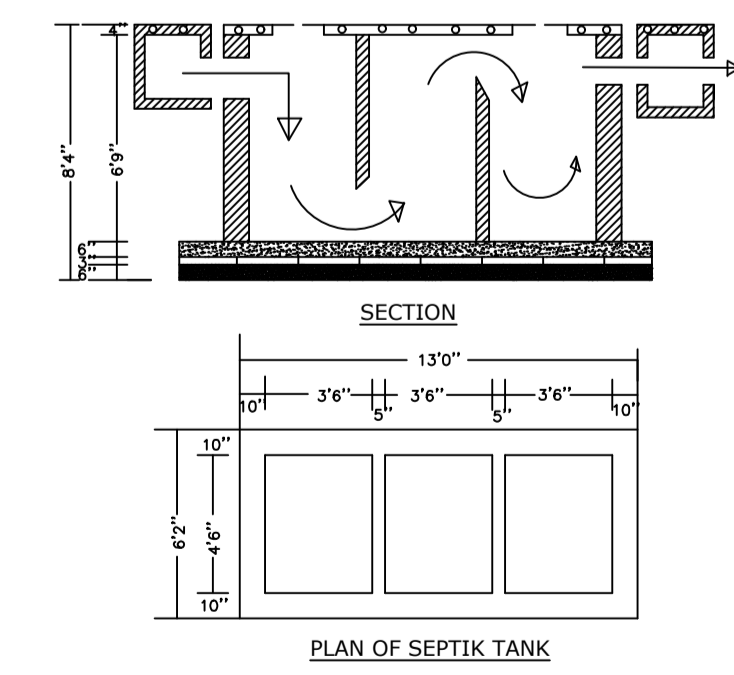
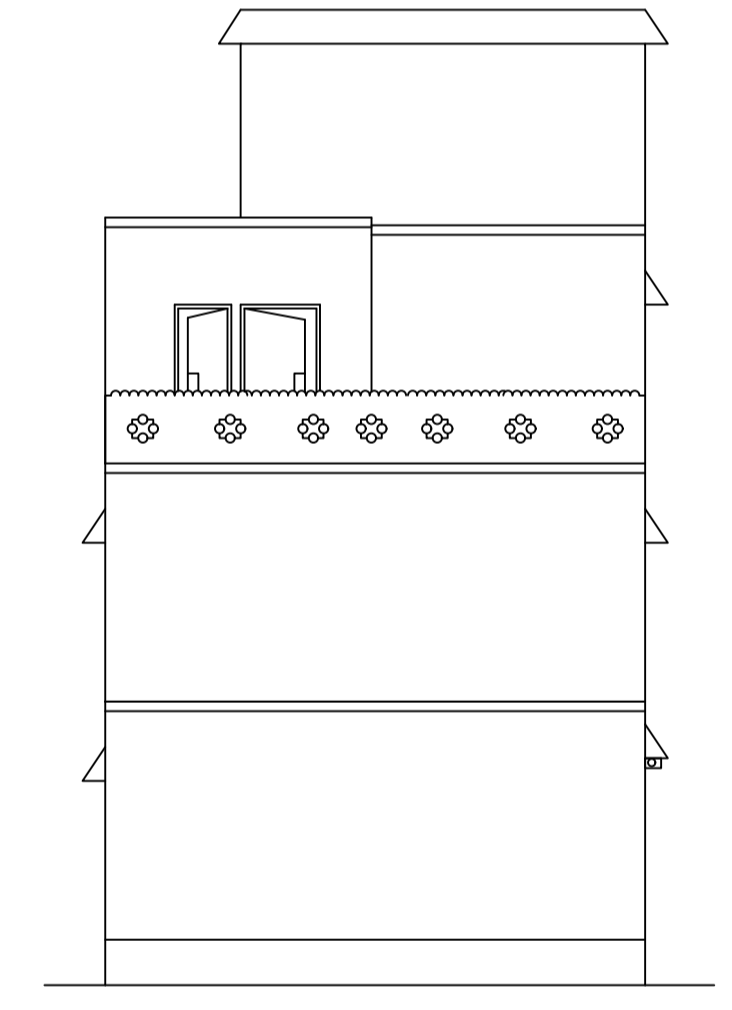
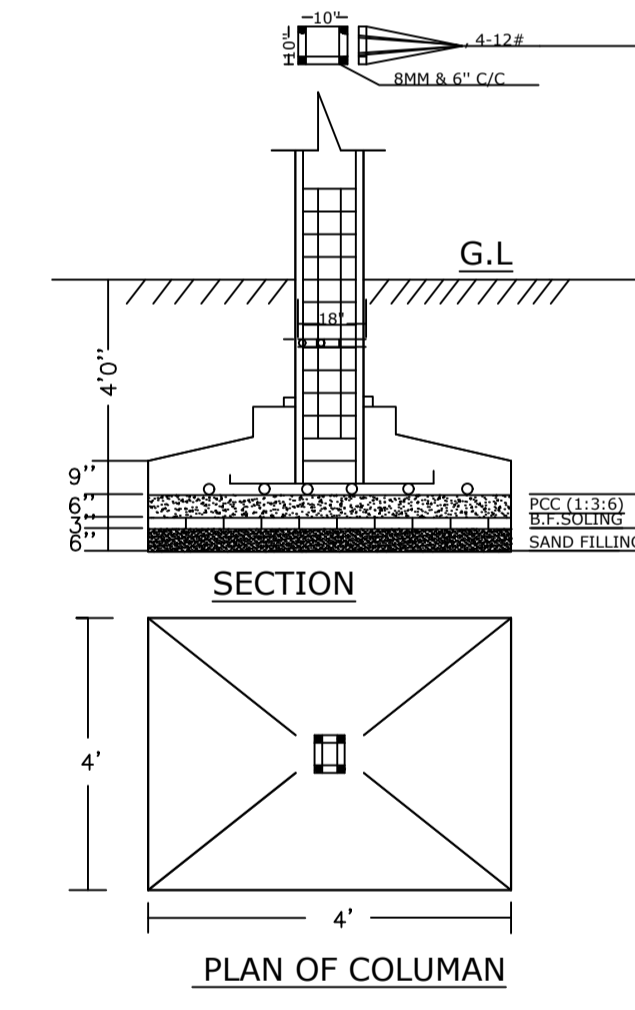
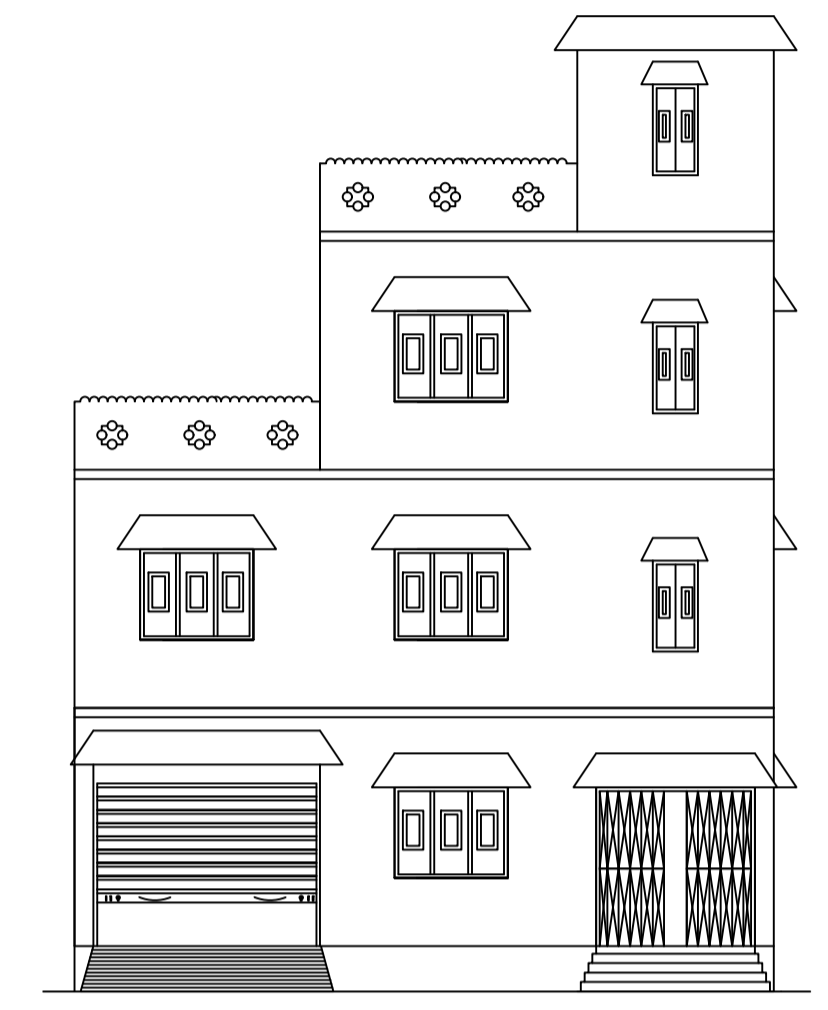
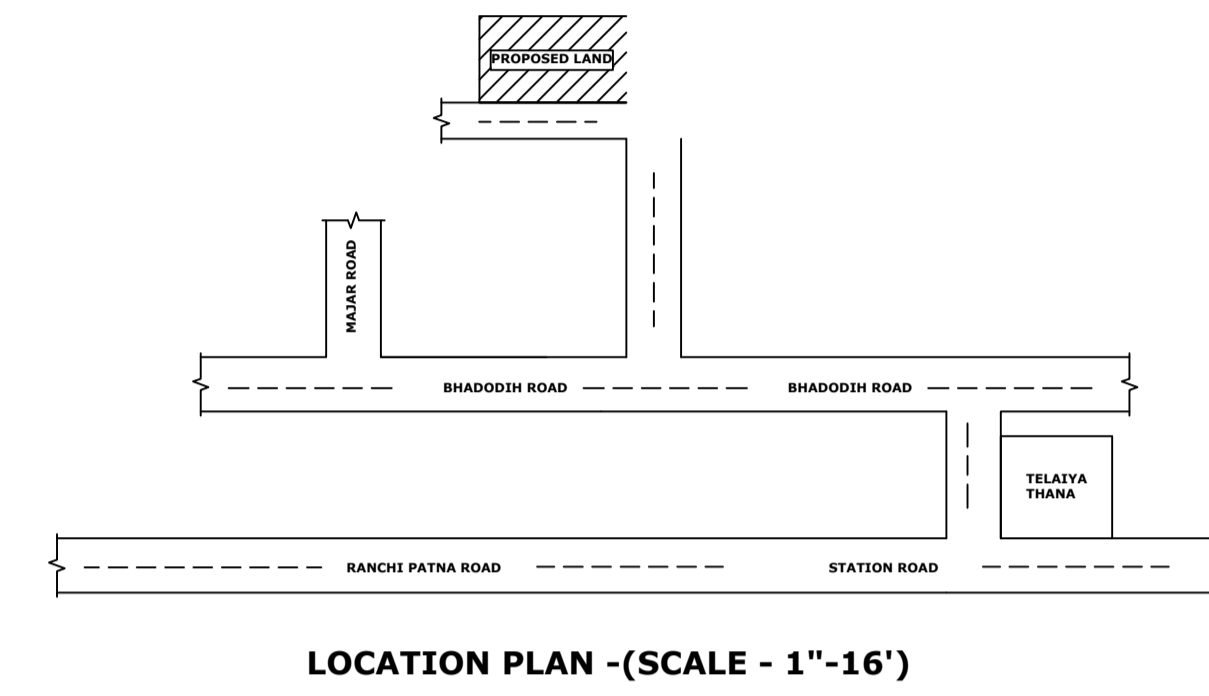
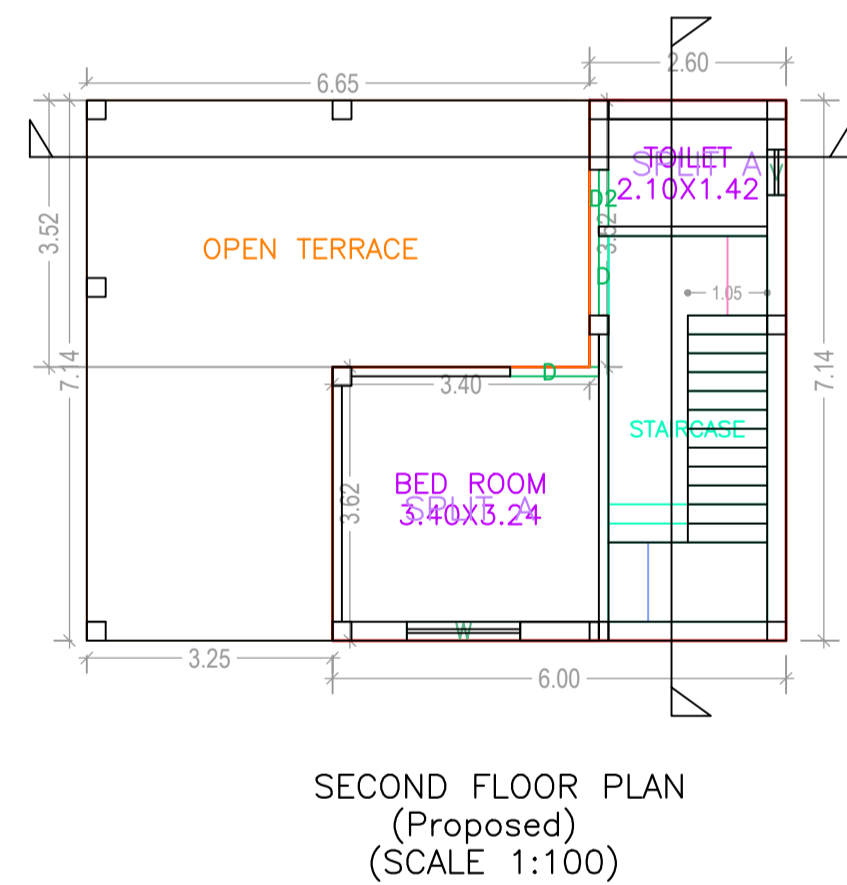
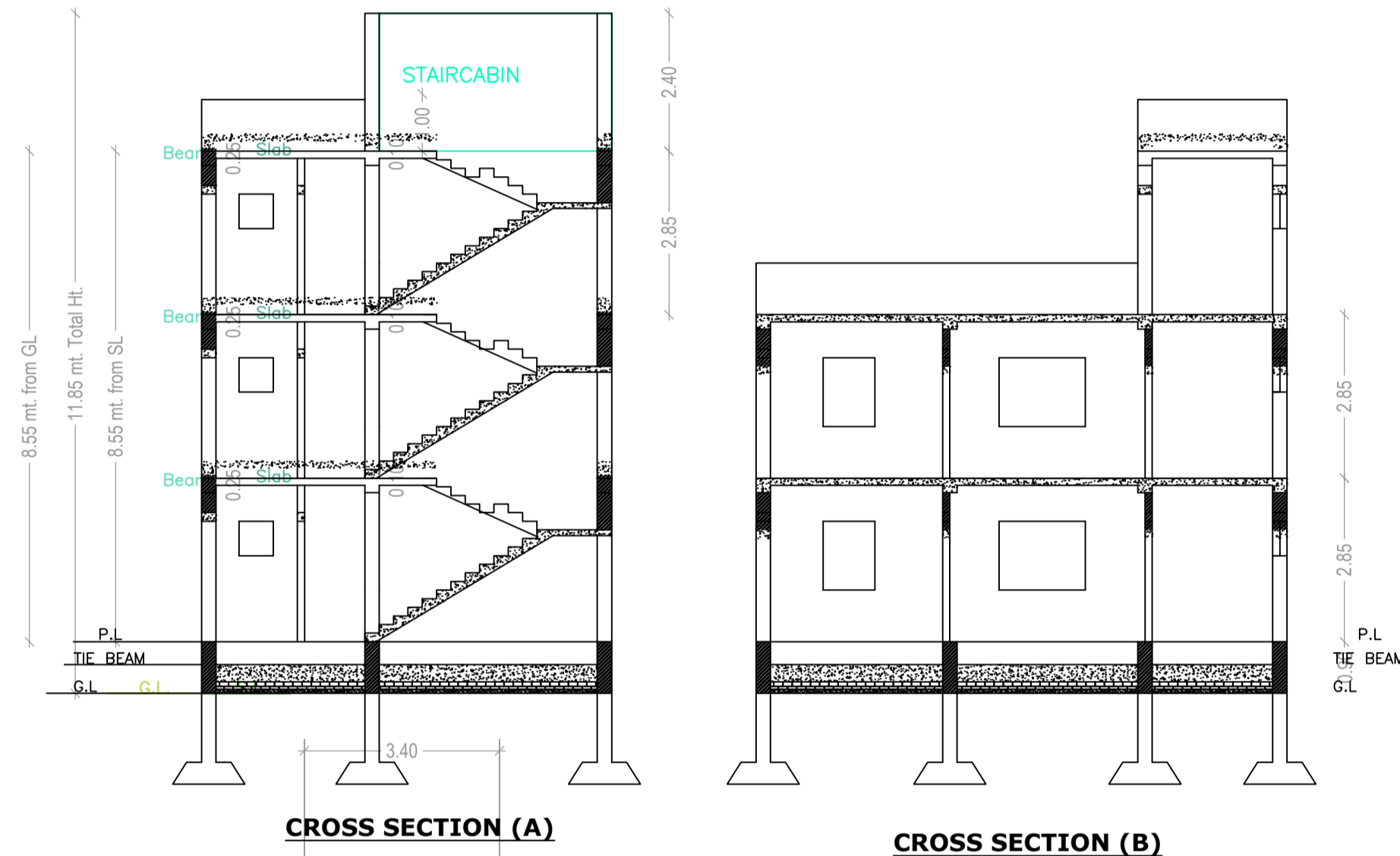
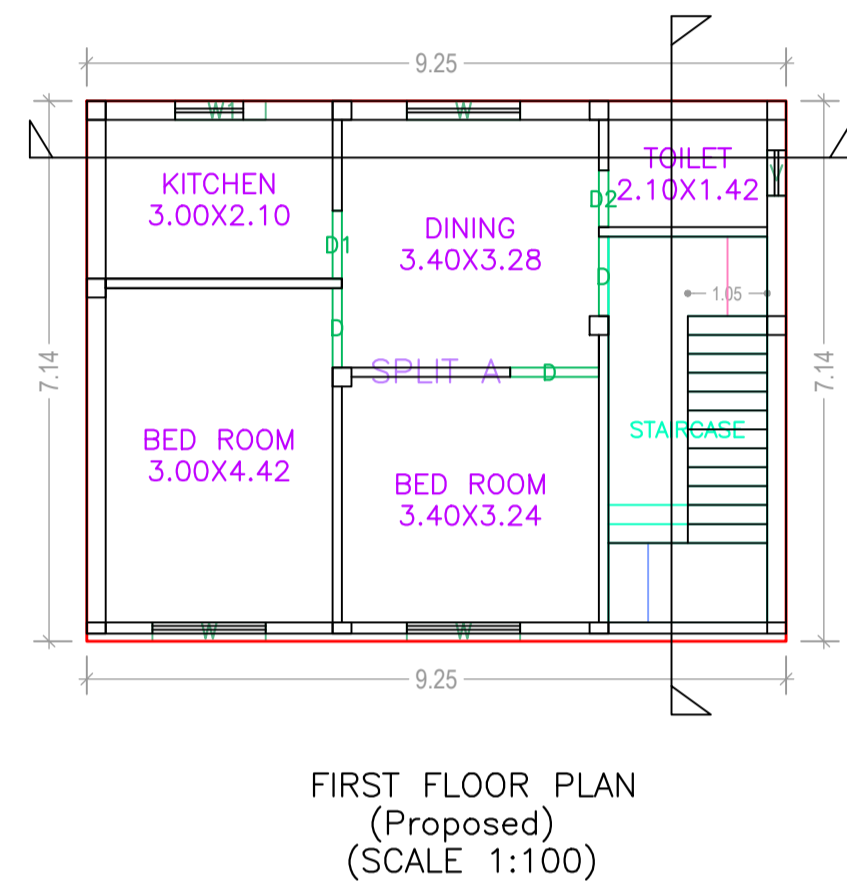
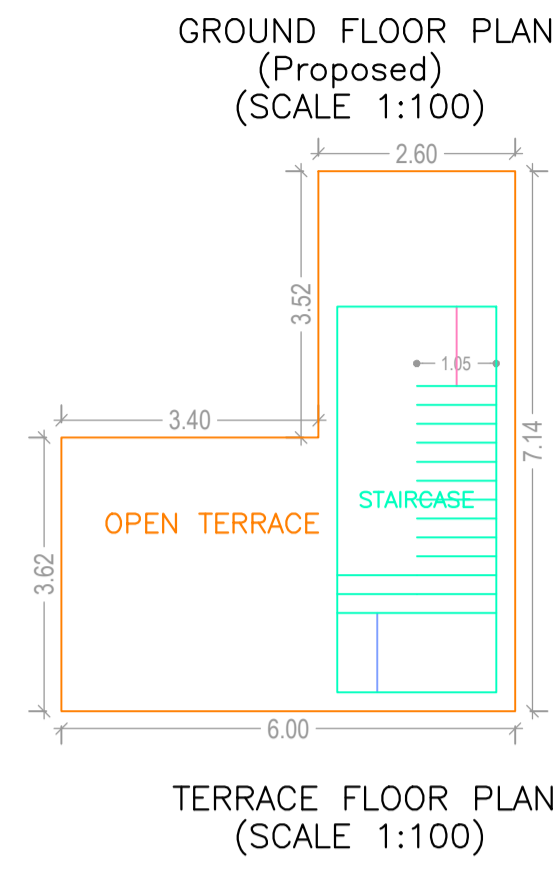
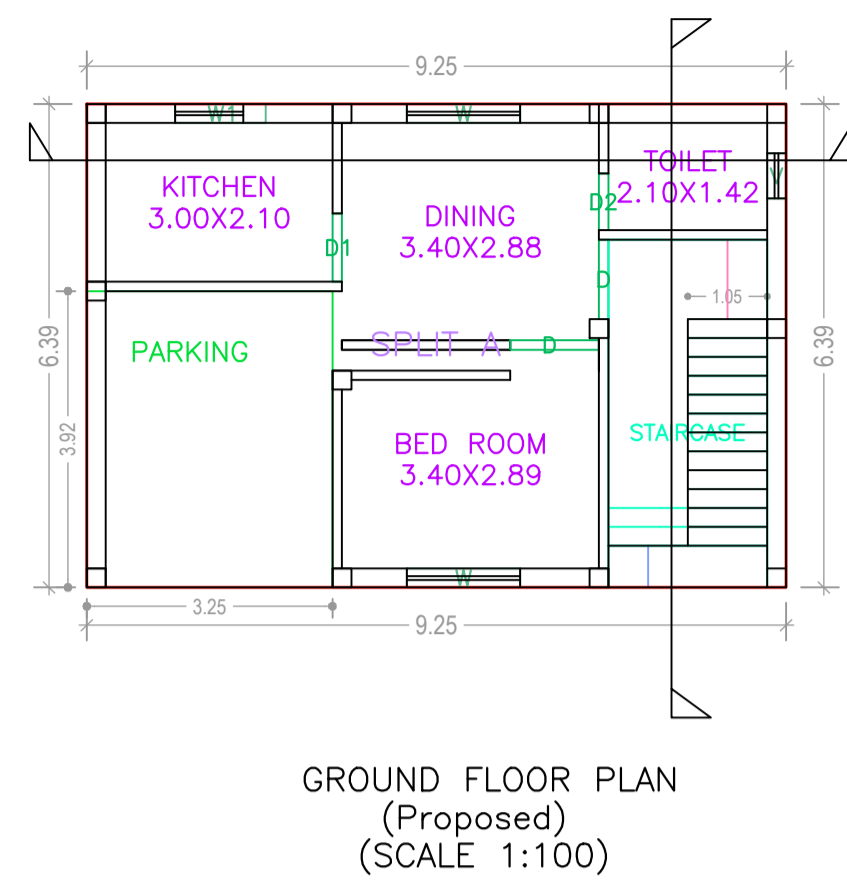

Floor Name	Total Built Up Area (Sq.mt.)	Proposed FAR Area (Sq.mt.) Resi.	Total FAR Area (Sq.mt.)	Total Consumed Additional FAR Area (Sq.mt.)	Tnmt (No.)
Ground Floor	59.15	59.15	59.15	59.15	01
First Floor	66.09	66.09	66.09	66.09	00
Second Floor	30.88	30.88	30.88	30.88	00
Terrace Floor	0.00	0.00	0.00	0.00	00
Total:	156.12	156.12	156.12	156.12	01
Total Number of Same Buildings	1				
Total:	156.12	156.12	156.12	156.12	01

BUILDING NAME	NAME	LENGTH	HEIGHT	NOS
A (RESIDENTIAL)	D2	0.75	2.10	03
A (RESIDENTIAL)	D1	0.90	2.10	02
A (RESIDENTIAL)	D	1.05	2.10	03
A (RESIDENTIAL)	D	1.18	2.10	03

BUILDING NAME	NAME	LENGTH	HEIGHT	NOS
A (RESIDENTIAL)	V	0.60	0.90	03
A (RESIDENTIAL)	W1	1.20	1.20	02
A (RESIDENTIAL)	W	1.50	1.20	06

FLOOR	Name	UnitBUA Type	UnitBUA Area	Carpet Area	No. of Rooms	No. of Tenement
GROUND FLOOR PLAN	SPLIT A	FLAT	92.07	90.56	4	1
FIRST FLOOR PLAN	SPLIT A	FLAT	0.00	0.00	5	0
SECOND FLOOR PLAN	SPLIT A	FLAT	0.00	0.00	1	0
FLOOR PLAN	SPLIT A	FLAT	0.00	0.00	1	0
Total:	-	-	92.07	90.56	11	1

LTP NAME AND SIGNATURE	STRUCTURAL ENG'S NAME AND SIGNATURE	BUILDER NAME AND SIGNATURE	DIGITAL SIGNATURE
KIRAN KUMARI JNP/ENG/0001/2019			