

SITE PLAN

Proposal Basic Information	
Proposal File No.	JNP/BP/0010/W/23/2019
Owner Name	YUVRAJ KUMAR
Khata No.	320
Plot No.	320
Village Name	Gomo
Use	Residential
SubUse	Other Residential Building

AREA STATEMENT	
JHUMRITLAYA NAGAR PARSISHAD	VERSION NO. : 1.0.34
REGION : JHARKHAND URBAN LOCAL BODIES	VERSION DATE: 13/03/2019
District: KODERMA	Plot Use: Residential
Authority: JHUMRITLAYA NAGAR PARSISHAD	Plot SubUse: Other Residential Building
Project No. JNP/0010/W/23/2019	Plot/Religion/Structure: NA
Project Type: General Proposal	Plot/Plot No.: 320
Project Type: Building Permission	North: Road Width - 3.6
Nature of Development: New	South: Plot No. - 6335 RAMESHWER PRASAD BERNWAL
Location of Development Area: Old Area	East: Plot No. - NU VENDOR
	West: Plot No. - 5818 NU VENDOR

AREA DETAILS:		SQ.MT
AREA OF PLOT (Minimum)	(A)	158.45
Deduction for Balance Plot Area/From Gross Plot Area)	(A-Deductions)	158.45
Common Plot		16.21
BALANCE AREA OF PLOT (Net Plot Area - Recreational/Amenity space)	(A-Deductions)	142.24
FLOOR AREA FOR COVERAGE (Net Plot Area + Road/Widening Area)	(A-Deductions)	158.45
Plot Area for FAR (Net Plot Area + Road/Widening Area)	(A-Deductions)	158.45

COVERAGE CHECK		SQ.MT
Permissible Coverage area (70.00 %)		110.91
Proposed Coverage Area (62.23 %)		98.43
Total Prop. Coverage Area (62.23 %)		98.43
Balance coverage area (9.77 %)		15.48

FAR CHECK		SQ.MT
Perm. FAR Area (1.50)		237.67
Total Perm. FAR area		237.67
Proposed FAR Area		190.86
Total Proposed FAR Area		190.86
Consumed FAR (Factor)		1.20
Balance FAR Area		46.80

BUILT UP AREA CHECK		SQ.MT
ARCHITECT (Regd)	KIRAN KUMARI	190.86
ENGINEER (Regd)	YUVRAJ KUMAR	
DEVELOPMENT AUTHORITY	LOCAL BODY	

COLOR INDEX	
PLOT BOUNDARY	Black
ASBITTING ROAD	Green
PROPOSED CONSTRUCTION	Red
COMMON PLOT	Yellow
ROAD WIDENING AREA	Blue
EXISTING (To be retained)	Orange
EXISTING (To be demolished)	Light Blue

Floor Name	Building Name		Total	
	Proposed Built Up Area (Sq.mt)	Proposed FAR Area (Sq.mt)	Total Proposed Built Up Area (Sq.mt)	Total FAR Area (Sq.mt)
Ground Floor	95.43	95.43	95.43	95.43
First Floor	95.43	95.43	95.43	95.43
Tersece Floor	0.00	0.00	0.00	0.00
Total	190.86	190.86	190.86	190.86

Building Name	Building Use	Building SubUse	Building Structure
A (RESIDENTIAL)	Residential	Bungalow/ Dwelling / Non Apartment	Non-Highrise

Building	No. of Same Bldg	Total Built Up Area (Sq.mt.)	Proposed FAR Area (Sq.mt.)	Total FAR Area (Sq.mt.)	Total Consumed Additional FAR	Tnem (No.)
A (RESIDENTIAL)	1	190.86	190.86	190.86	190.86	01
Grand Total :	1	190.86	190.86	190.86	190.86	01

LTP NAME AND SIGNATURE	STRUCTURAL ENGS NAME AND SIGNATURE	BUILDER NAME AND SIGNATURE	DIGITAL SIGNATURE
KIRAN KUMARI JNP/ENG/0001/2019			

Proposal Basic Information	
Proposal File No.	JNP/EP/0010/W23/2019
Owner Name	YUVRAJ KUMAR
Khata No	320
Plot No	320
Village Name	Gomo
Use	Residential
SubUse	Other Residential Building

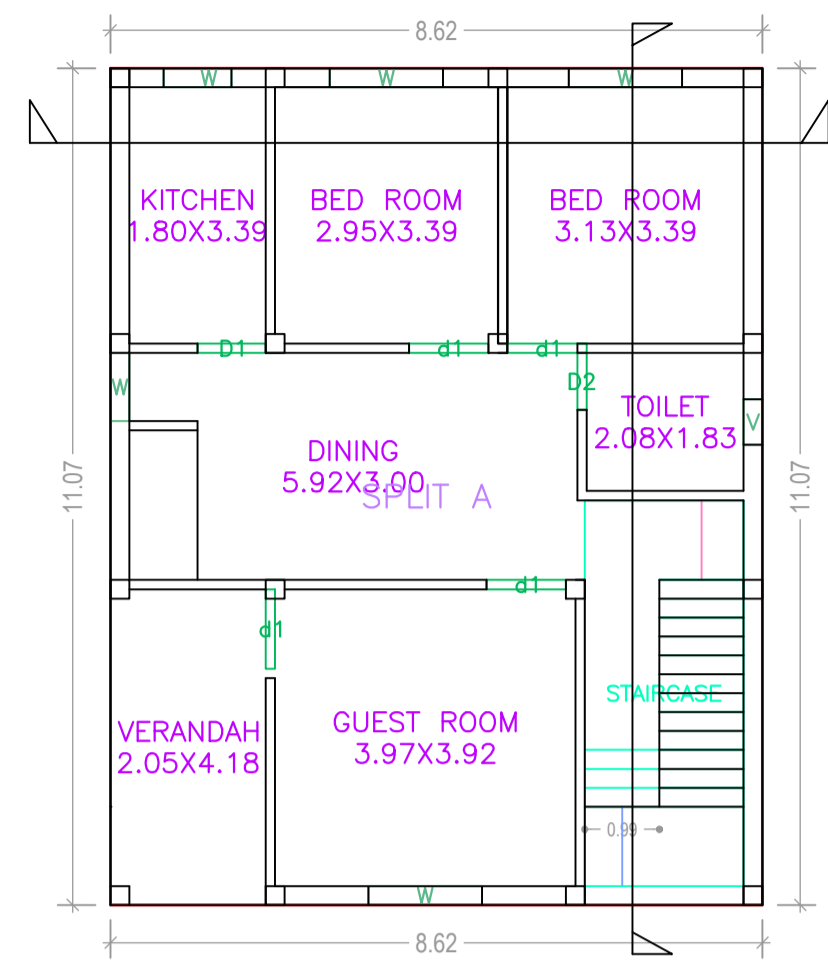

GROUND FLOOR PLAN (Proposed) (SCALE 1:100)

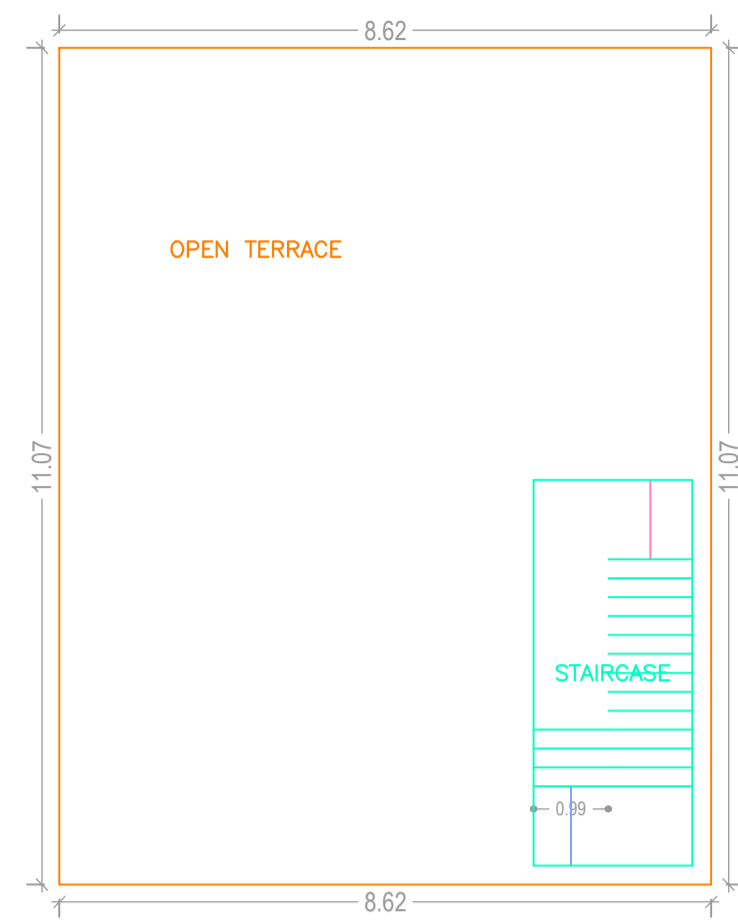

TERRACE FLOOR PLAN (SCALE 1:100)

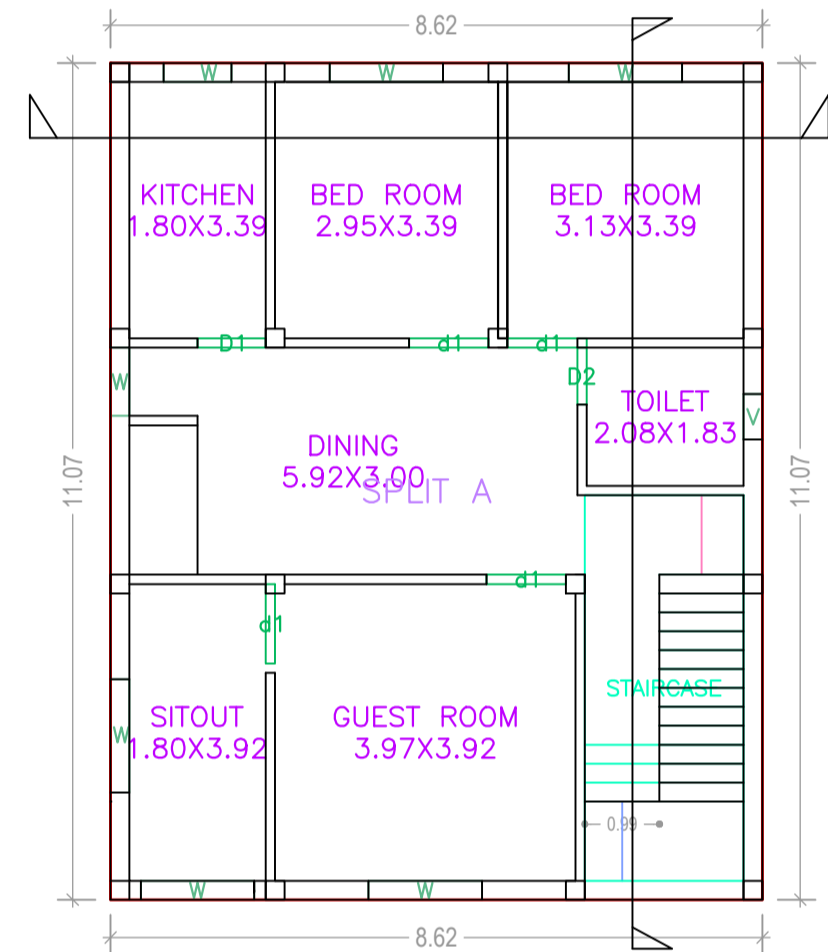

FIRST FLOOR PLAN (Proposed) (SCALE 1:100)

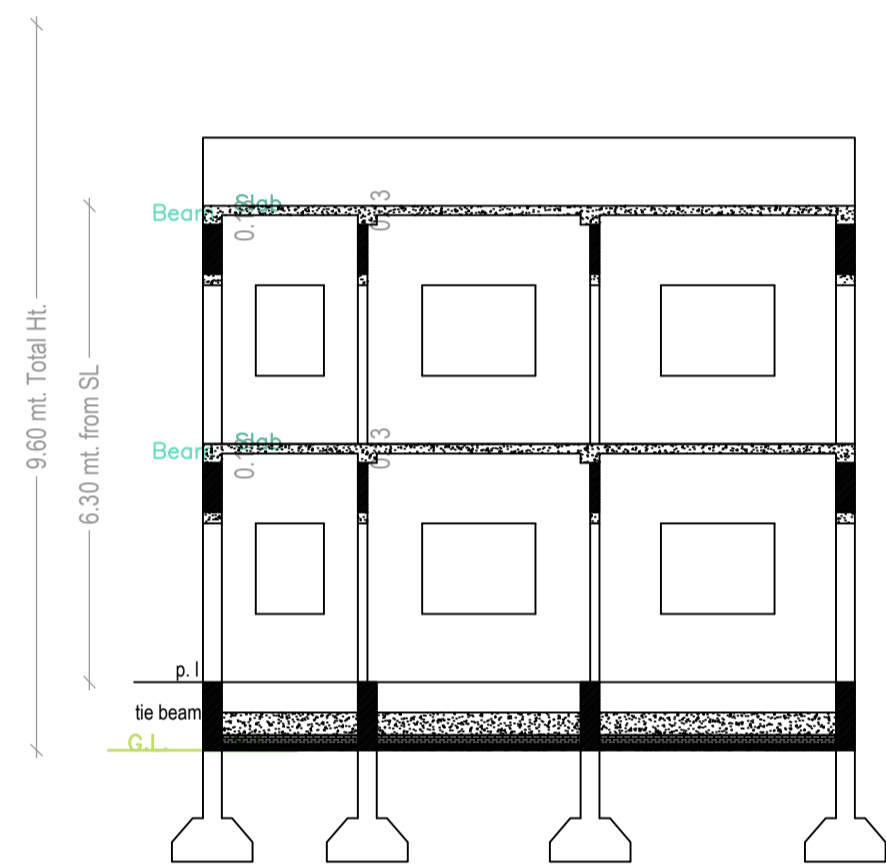

CROSS SECTION (B)

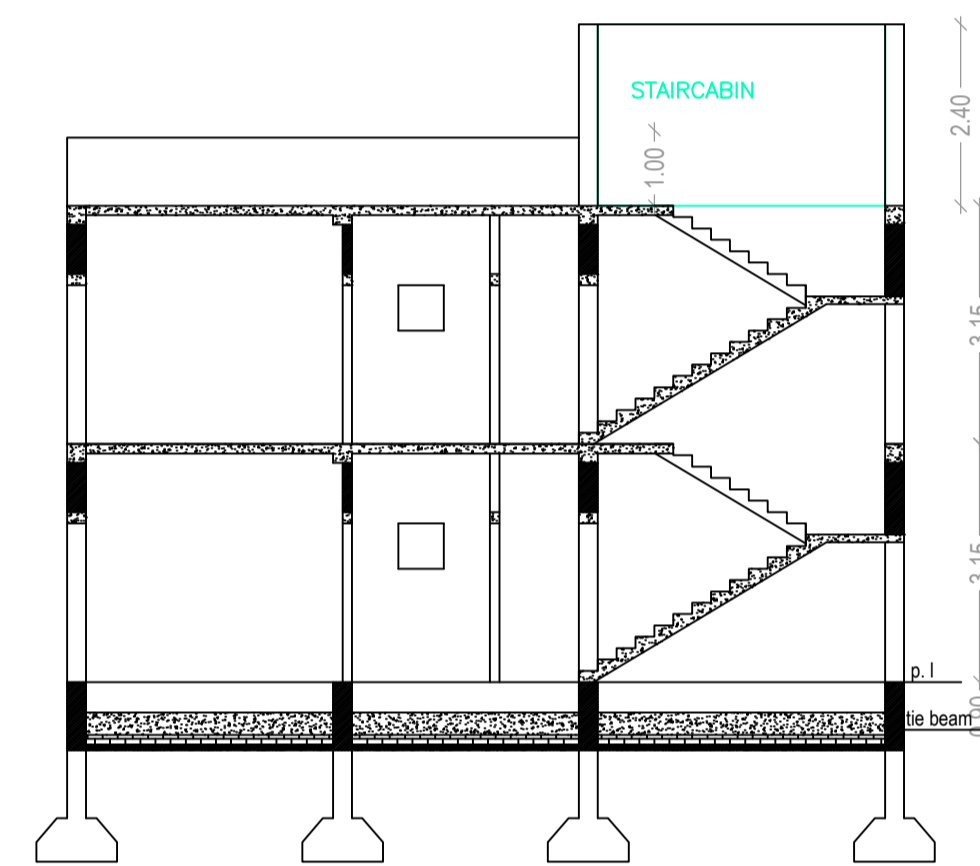

CROSS SECTION (A)

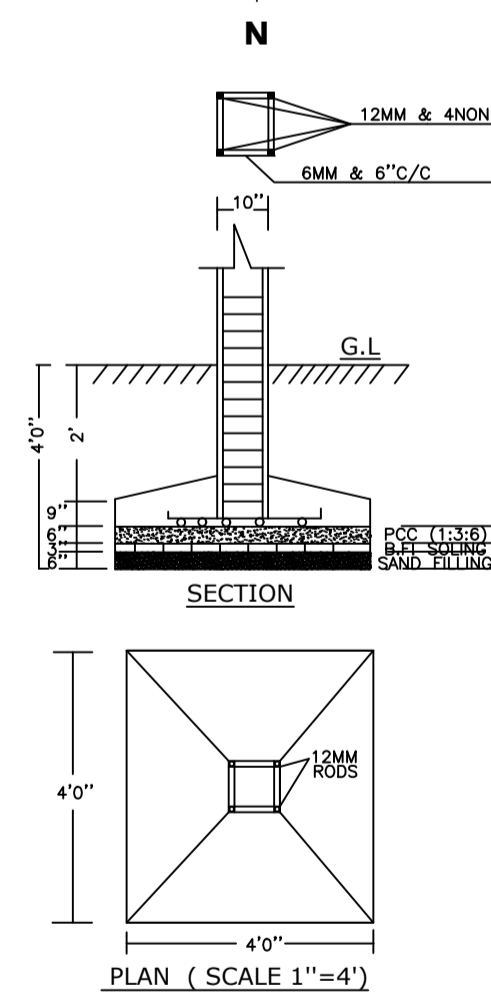

PLAN (SCALE 1"=4')

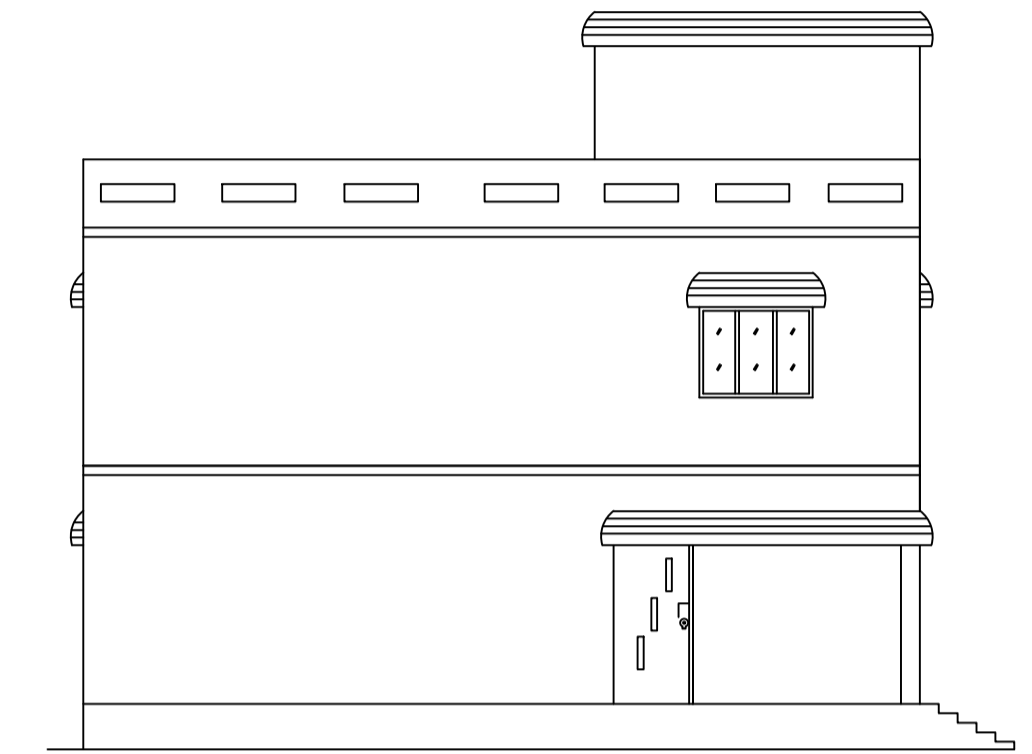

CROSS ELEVATION

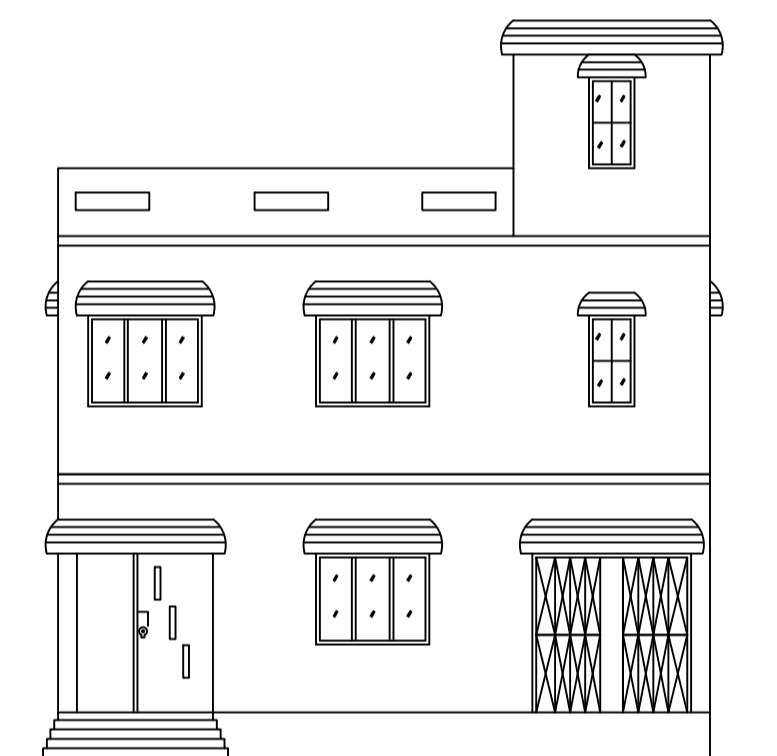

FRONT ELEVATION

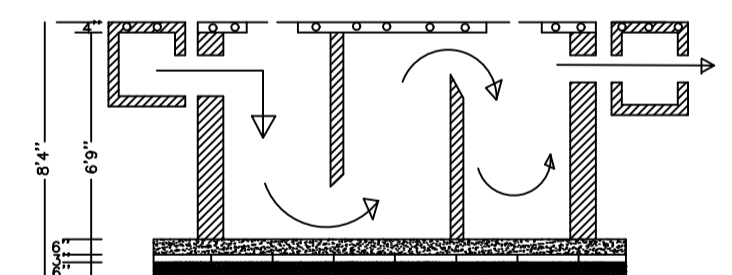

SECTION

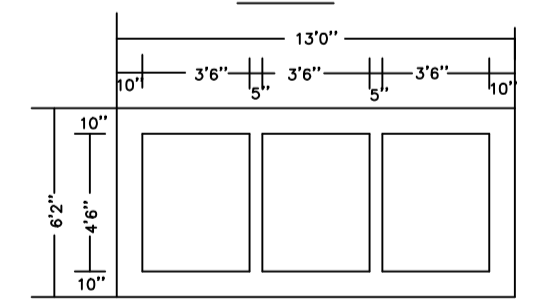

PLAN OF SEPTIC TANK

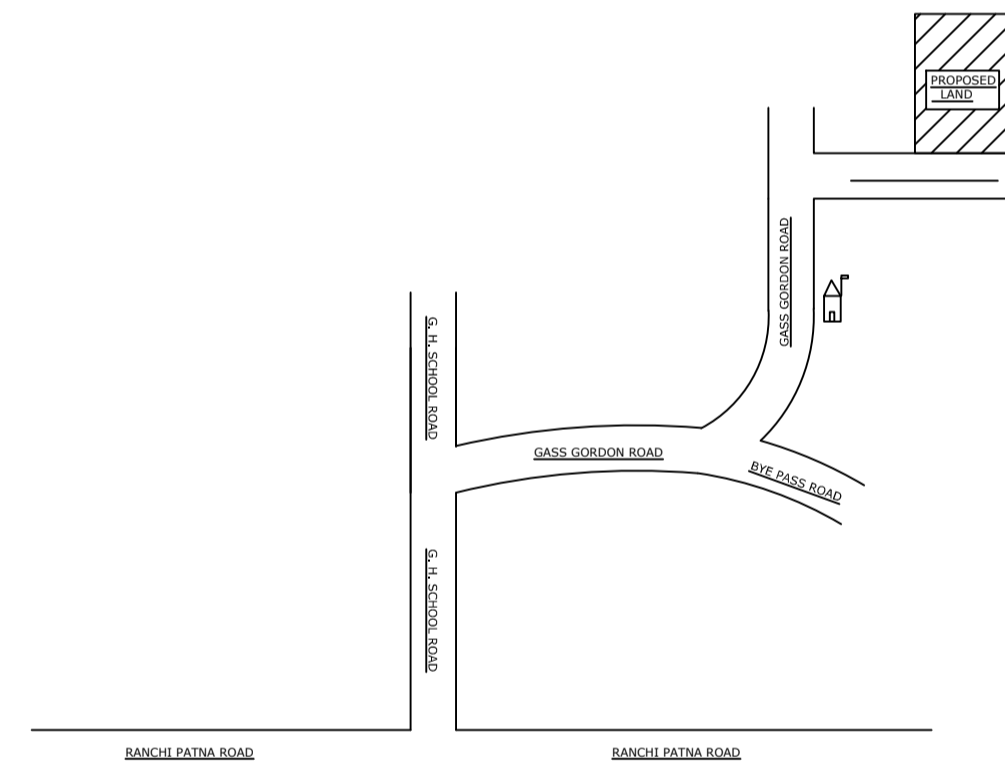

LOCATION PLAN (SCALE -1"=16')

Building :A (RESIDENTIAL)

Floor Name	Total Built Up Area (Sq.mt.)	Proposed FAR Area (Sq.mt.) Resi.	Total FAR Area (Sq.mt.)	Total Consumed Additional FAR Area (Sq.mt.)	Tnmt (No.)
Ground Floor	95.43	95.43	95.43	95.43	01
First Floor	95.43	95.43	95.43	95.43	00
Terrace Floor	0.00	0.00	0.00	0.00	00
Total :	190.86	190.86	190.86	190.86	01
Total Number of Same Buildings	1				
Total :	190.86	190.86	190.86	190.86	01

SCHEDULE OF DOOR:

BUILDING NAME	NAME	LENGTH	HEIGHT	NOS
A (RESIDENTIAL)	D2	0.75	2.10	02
A (RESIDENTIAL)	D1	0.90	2.10	02
A (RESIDENTIAL)	d1	1.05	2.10	08

SCHEDULE OF WINDOW/VENTILATION:

BUILDING NAME	NAME	LENGTH	HEIGHT	NOS
A (RESIDENTIAL)	V	0.60	0.90	02
A (RESIDENTIAL)	W	0.90	1.20	02
A (RESIDENTIAL)	W	0.90	2.10	02
A (RESIDENTIAL)	W	1.50	1.20	08

UnitBUA Table for Building :A (RESIDENTIAL)

FLOOR	Name	UnitBUA Type	UnitBUA Area	Carpet Area	No. of Rooms	No. of Tenement
GROUND FLOOR PLAN	SPLIT A	FLAT	152.02	151.17	7	1
FIRST FLOOR PLAN	SPLIT A	FLAT	0.00	0.00	7	0
Total:	-	-	152.02	151.17	14	1

LTP NAME AND SIGNATURE	STRUCTURAL ENG'S NAME AND SIGNATURE	BUILDER NAME AND SIGNATURE	DIGITAL SIGNATURE
KIRAN KUMARI JNP/ENG/0001/2019			