

FAR & Tenement Details (Table 4c-1)

Building	No. of Same Bldg	Total Built Up Area (Sq.mt.)	Proposed FAR Area (Sq.mt.) Resi.	Total FAR Area (Sq.mt.)	Total Consumed Additional FAR Area (Sq.mt.)	Tnmt (No.)
A (RESIDENTIAL)	1	229.66	229.66	229.66	229.66	01
Grand Total :	1	229.66	229.66	229.66	229.66	01

Proposal Basic Information

Proposal File No.	JNP/BI/0067/W06/2019
Owner Name	SHAHJADI
Khata No	82
Plot No	1345
Village Name	Asana
Use	Residential
SubUse	Bungalow/ Dwelling / Non Apartment

AREA STATEMENT	VERSION NO. : 1.0.46
JHUMRITILAIYA NAGAR PARISHAD	VERSION DATE: 22/06/2020
PROJECT DETAIL:	
Region: JHARKHAND URBAN LOCAL BODIES	Plot Use: Residential
District: KODERMA	Plot SubUse: Bungalow/ Dwelling / Non Apartment
Authority: JHUMRITILAIYA NAGAR PARISHAD	PlotNearbyReligiousStructure: NA
Inward No: JNP/BI/0067/W06/2019	Plot/SubPlot No: 1345
Application Type: General Proposal	North: Plot No. - KABIRUDDIN
Project Type: Building Permission	South: Road Width - 2.14
Nature of Development: New	East: Plot No. - ANWAR KHAN
Location of Development Area: Old Area	West: Road Width - 3.65
AREA DETAILS:	
AREA OF PLOT (Minimum)	(A) 201.18
NET AREA OF PLOT(Gross Plot Area - Deduction from Gross Plot area)	(A-Deductions) 201.18
Deduction for Balance Plot Area(from Gross Plot Area)	
Common Plot	19.96
Total	19.96
BALANCE AREA OF PLOT(Net Plot Area - Recreational/Amenity space)	(A-Deductions) 181.22
PLOT AREA FOR COVERAGE(Net Plot Area)	(A-Deductions) 201.18
Plot Area for FAR (Net Plot Area + RoadWidening Area)	(A-Deductions) 201.18
COVERAGE CHECK	
Permissible Coverage area (70.00 %)	140.83
Proposed Coverage Area (57.08 %)	114.83
Total Prop. Coverage Area (57.08 %)	114.83
Balance coverage area (12.92 %)	26.00
FAR CHECK	
Perm. FAR Area (1.50)	301.77
Total Perm. FAR area	301.77
Residential FAR	229.65
Proposed FAR Area	229.65
Total Proposed FAR Area	229.65
Consumed FAR (Factor)	1.14
Balance FAR Area	72.12
BUILT UP AREA CHECK	
Total Proposed BuiltUp Area	229.66
ARCHITECT (Regd)	KIRAN KUMARI
ENGINEER (Regd)	
SUPERVISOR (Regd)	
OWNER (Regd)	SHAHJADI
DEVELOPMENT AUTHORITY	LOCAL BODY

COLOR INDEX	
PLOT BOUNDARY	Black
ABUTTING ROAD	Green
PROPOSED CONSTRUCTION	Red
COMMON PLOT	Yellow
ROAD WIDENING AREA	Blue
EXISTING (To be retained)	Blue
EXISTING (To be demolished)	Yellow

Buildingwise Floor FAR Details

Floor Name	Building Name A (RESIDENTIAL)		Total	
	Proposed Built Up Area (Sq.mt.)	Proposed FAR Area (Sq.mt.)	Total Proposed Built Up Area (Sq.mt.)	Total FAR Area (Sq.mt.)
Ground Floor	114.83	114.83	114.83	114.83
First Floor	114.83	114.83	114.83	114.83
Terrace Floor	0.00	0.00	0.00	0.00
Total :	229.66	229.66	229.66	229.66

Building USE/SUBUSE Details

Building Name	Building Use	Building SubUse	Building Structure
A (RESIDENTIAL)	Residential	Bungalow/ Dwelling / Non Apartment	Non-Highrise

LTP NAME AND SIGNATURE	STRUCTURAL ENG'S NAME AND SIGNATURE	BUILDER NAME AND SIGNATURE	DIGITAL SIGNATURE
KIRAN KUMARI JNP/ENG/0001/2019			

Proposal Basic Information

Proposal File No.	JNP/BP/0067/W06/2019
Owner Name	SHAHJADI
Khata No	82
Plot No	1345
Village Name	Asana
Use	Residential
SubUse	Bungalow/ Dwelling / Non Apartment

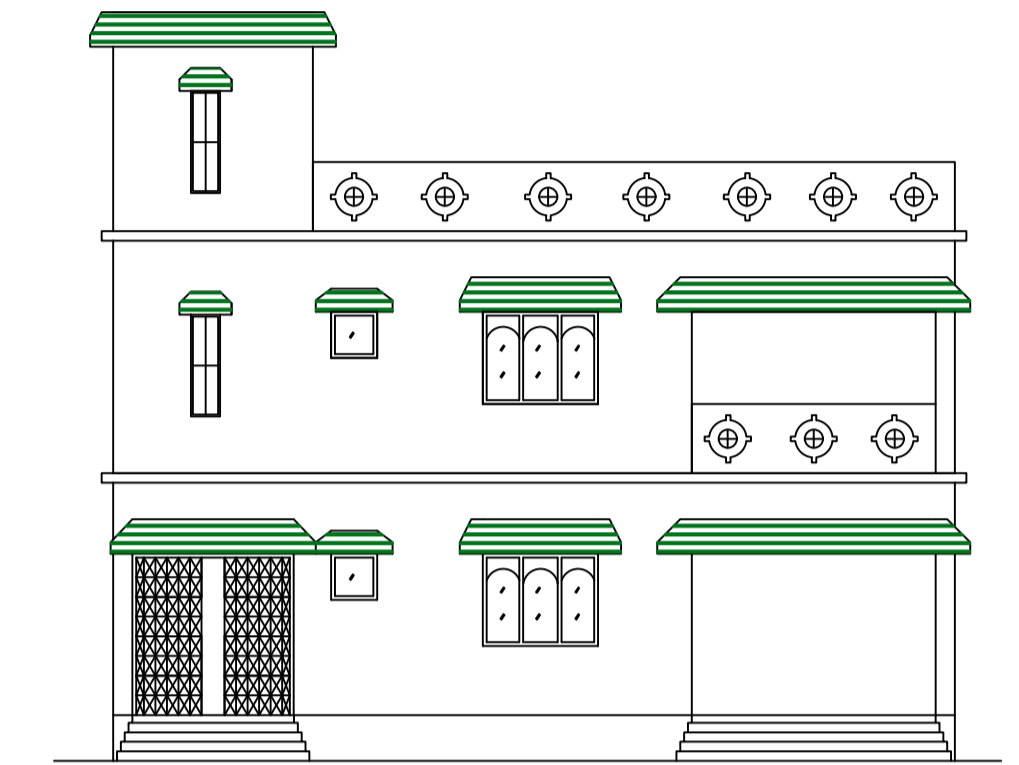
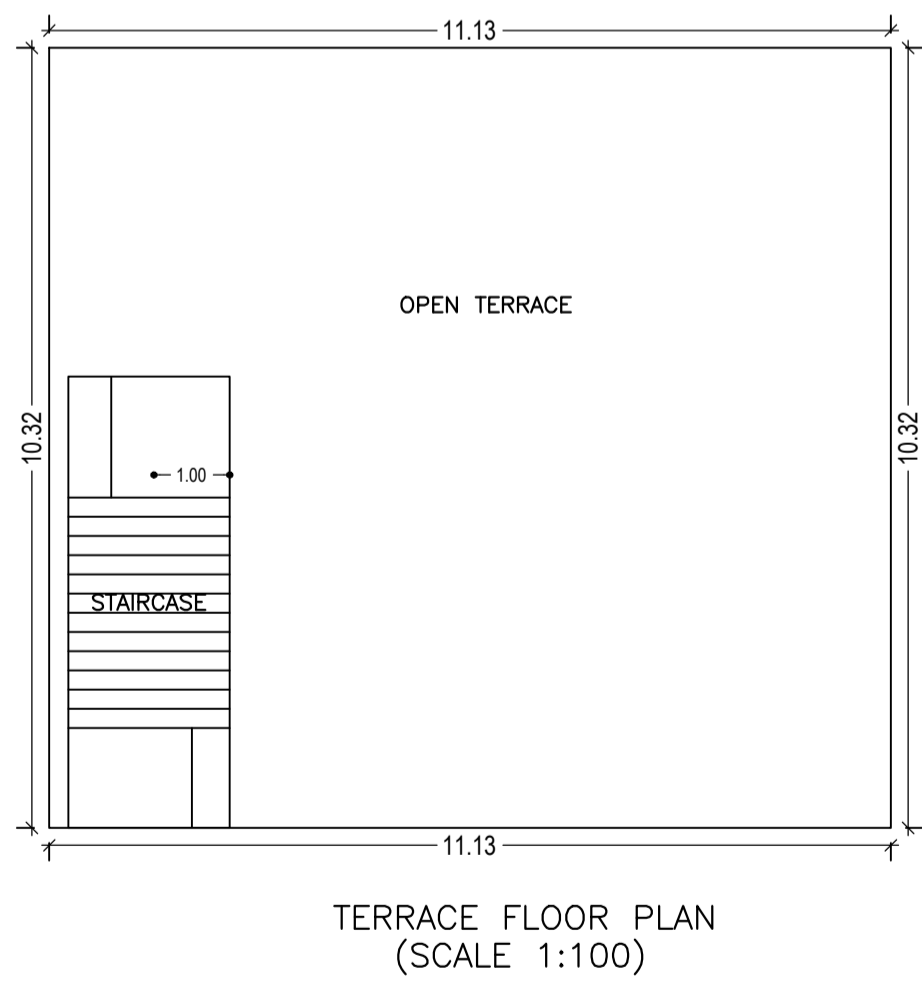
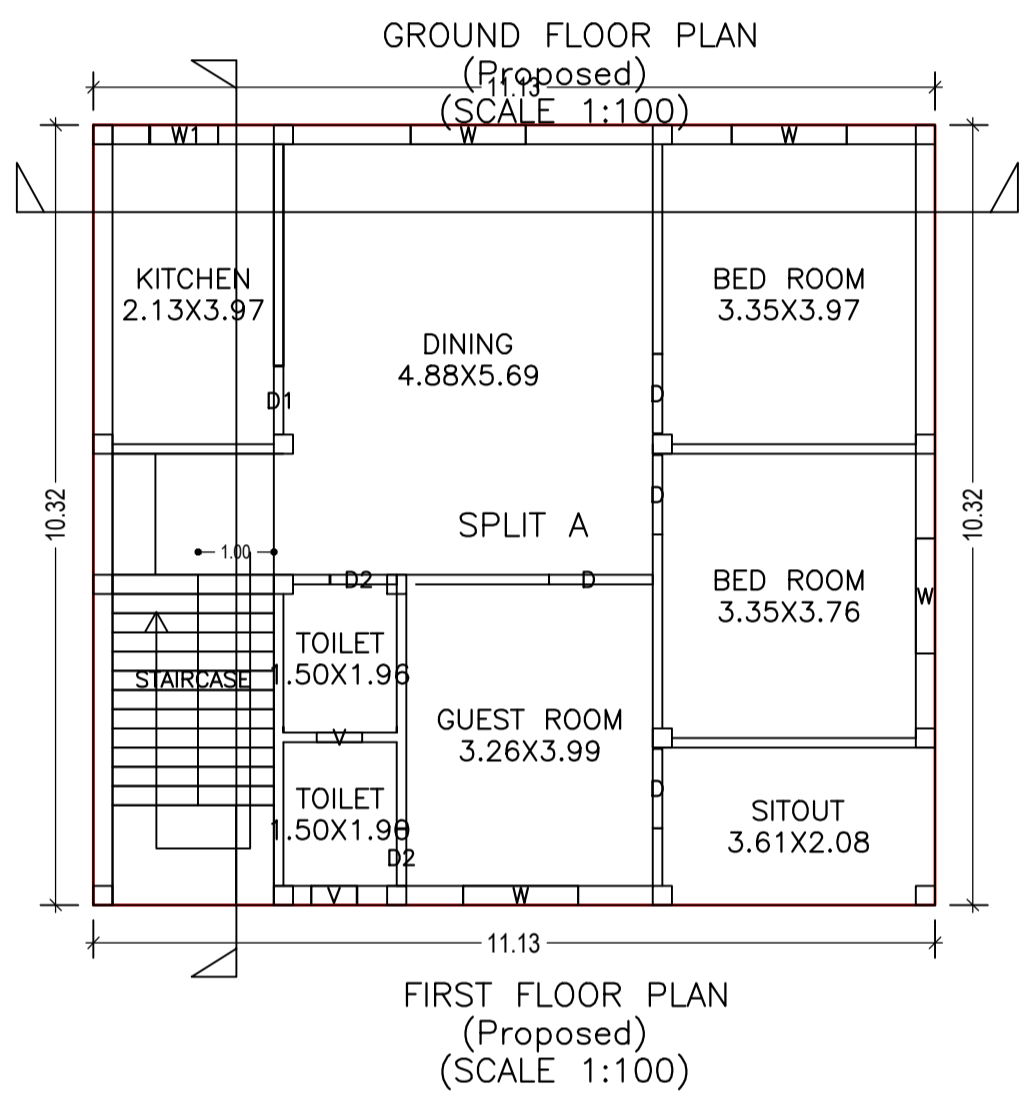
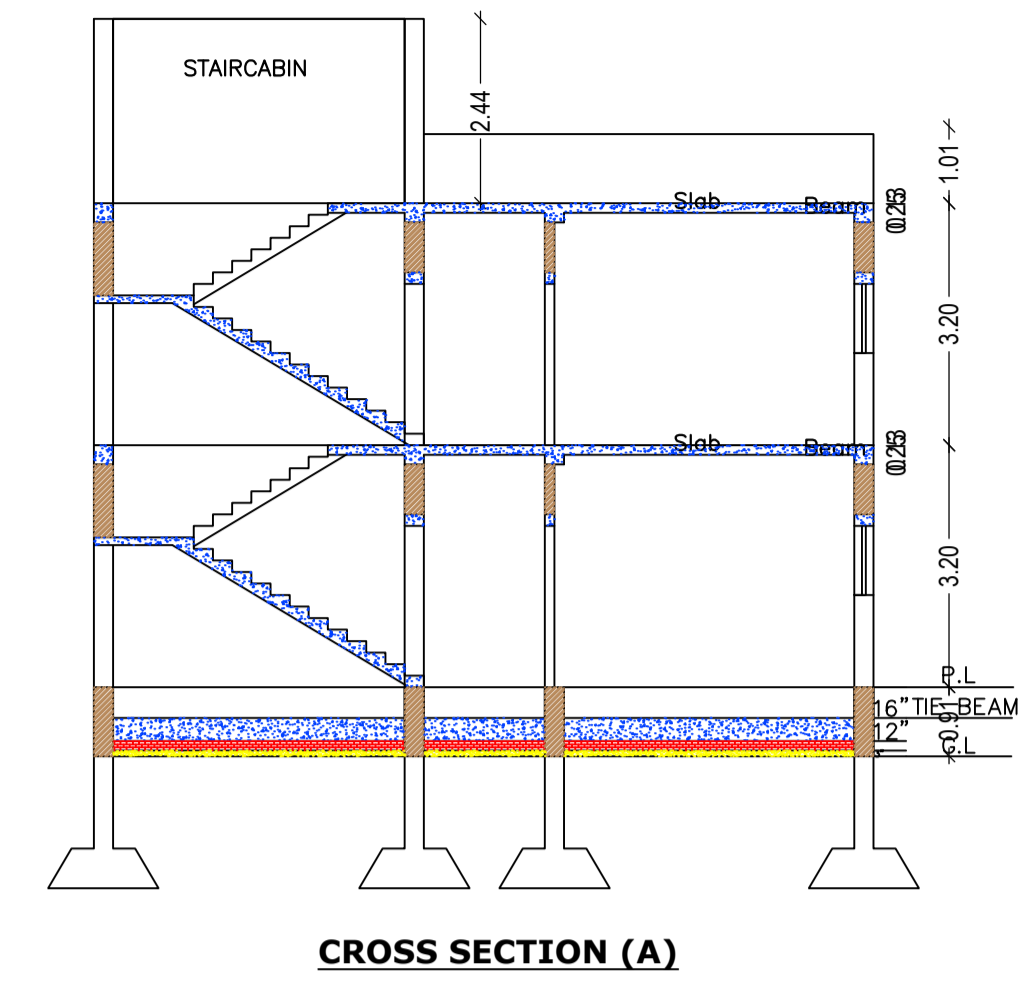
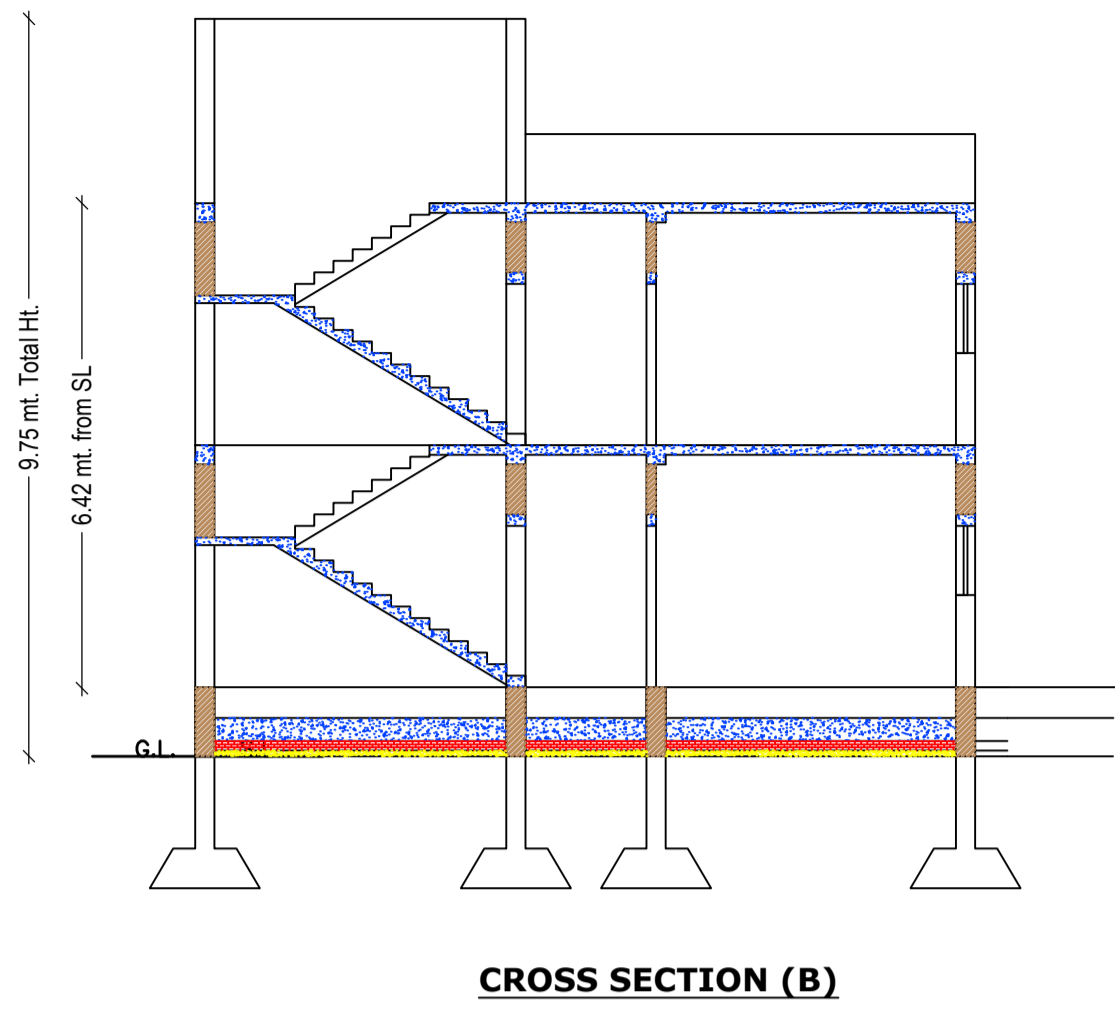
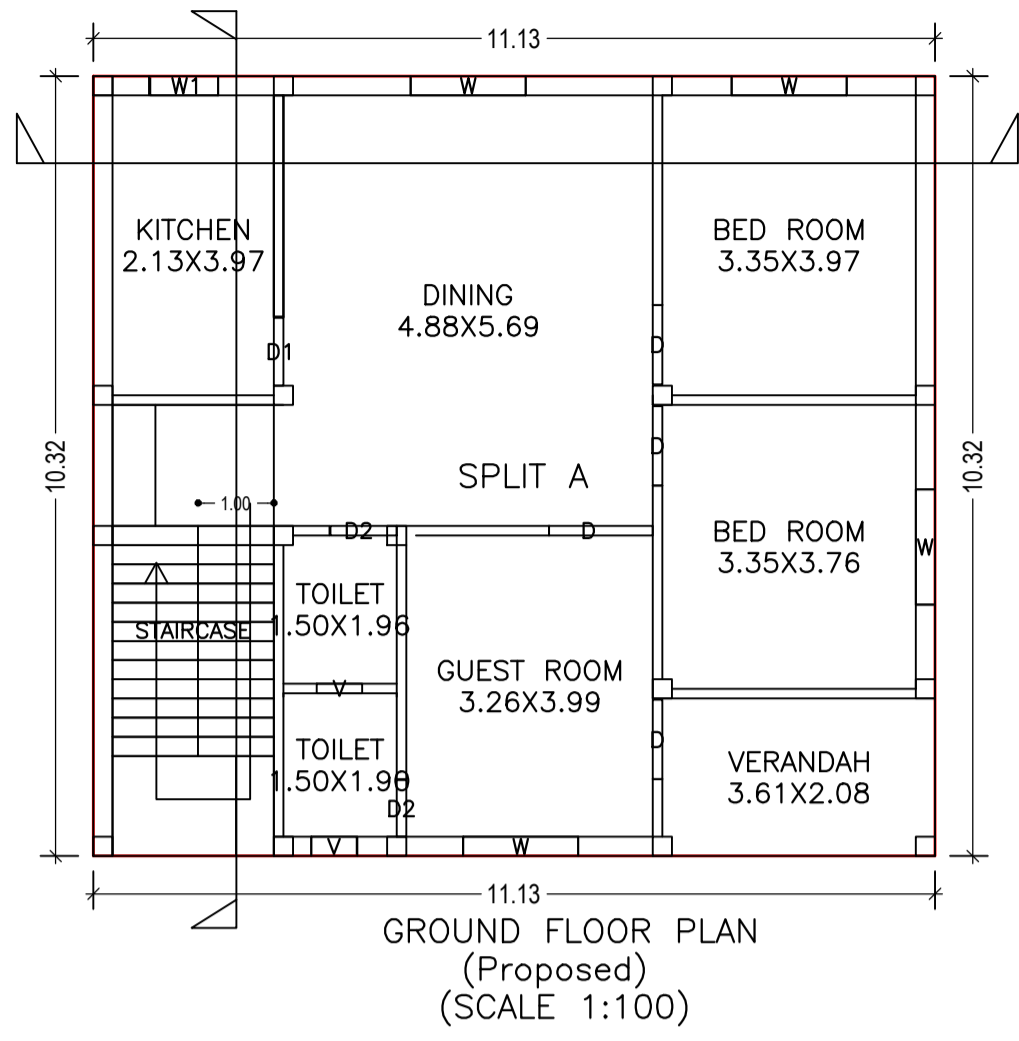

FRONT ELEVATION

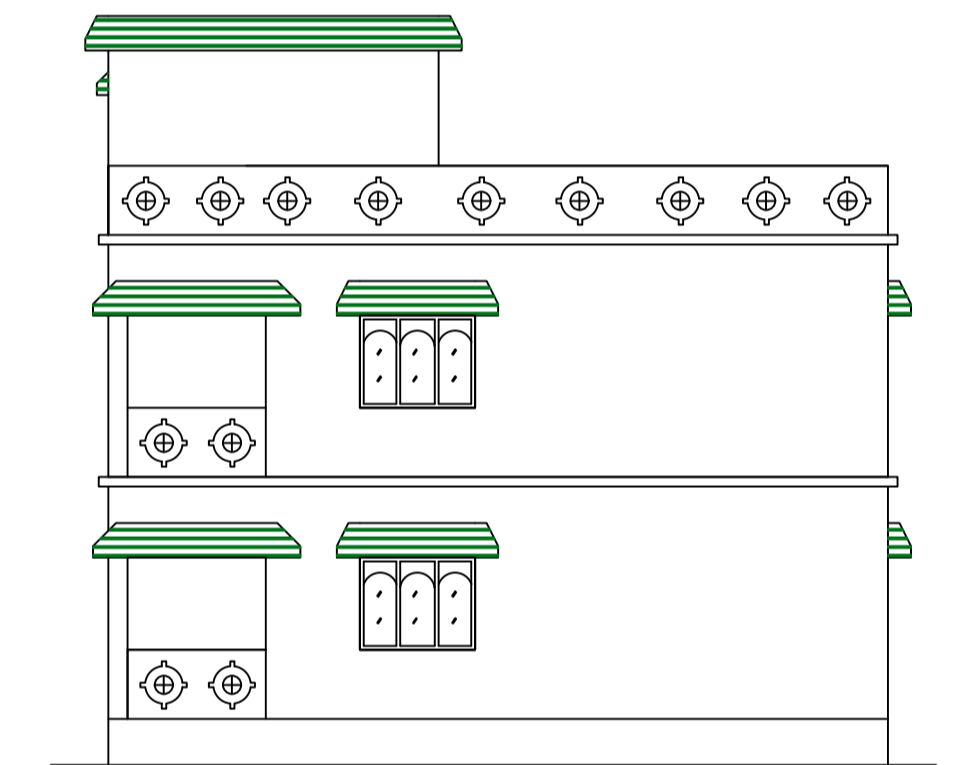
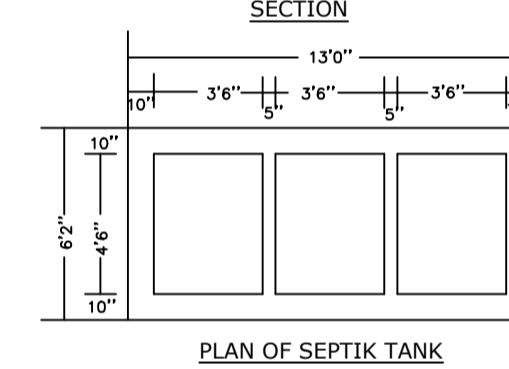
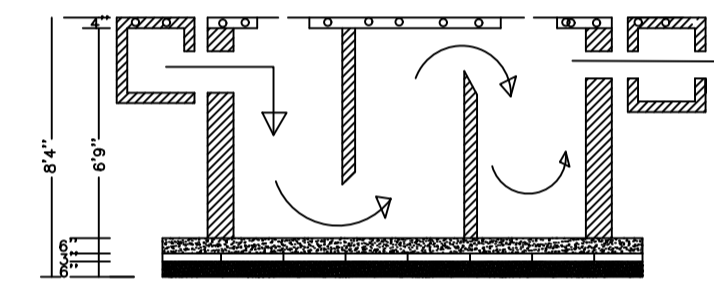

CROSS ELEVATION

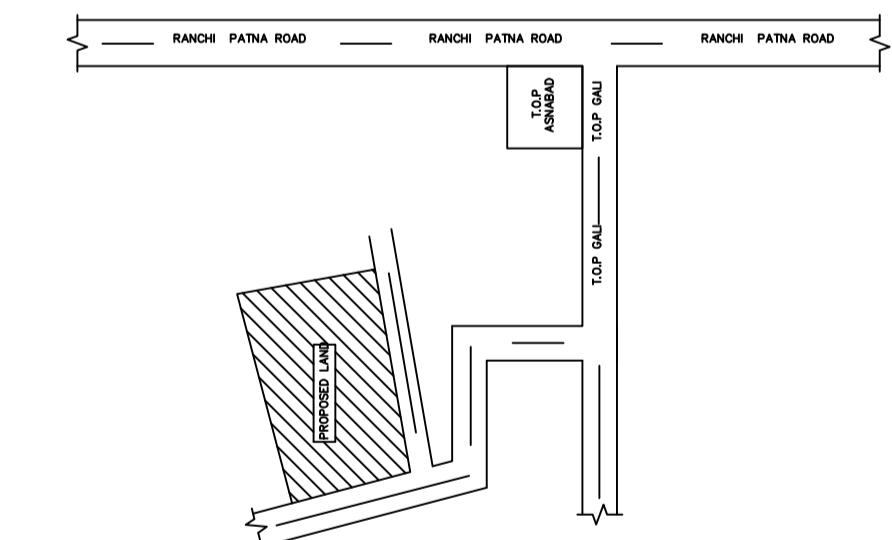

LOCATION PLAN (SCALE -1''16')

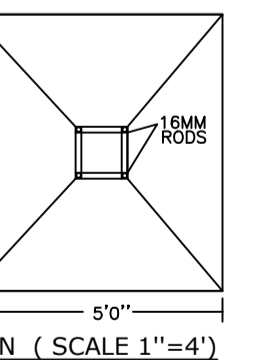
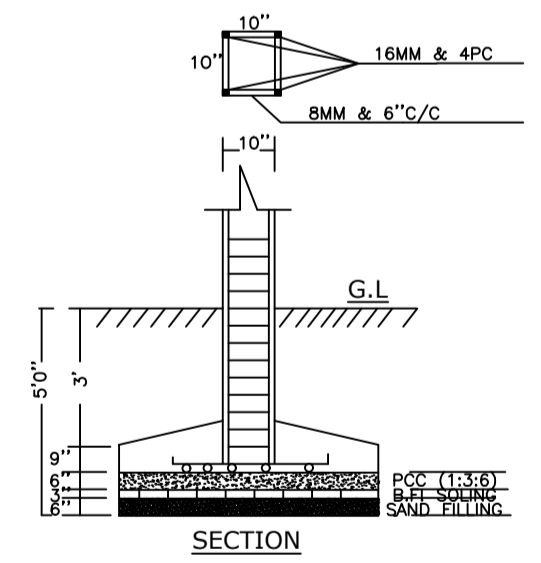

PLAN (SCALE 1''=4')

Building :A (RESIDENTIAL)

Floor Name	Total Built Up Area (Sq.mt.)	Proposed FAR Area (Sq.mt.) Resi.	Total FAR Area (Sq.mt.)	Total Consumed Additional FAR Area (Sq.mt.)	Tnmt (No.)
Ground Floor	114.83	114.83	114.83	114.83	01
First Floor	114.83	114.83	114.83	114.83	00
Terrace Floor	0.00	0.00	0.00	0.00	00
Total:	229.66	229.66	229.66	229.66	01
Total Number of Same Buildings	1				
Total:	229.66	229.66	229.66	229.66	01

SCHEDULE OF DOOR:

BUILDING NAME	NAME	LENGTH	HEIGHT	NOS
A (RESIDENTIAL)	D2	0.75	2.10	02
A (RESIDENTIAL)	D2	0.88	2.10	02
A (RESIDENTIAL)	D1	0.90	2.10	02
A (RESIDENTIAL)	D	1.05	2.10	06
A (RESIDENTIAL)	D	1.37	2.10	02

SCHEDULE OF WINDOW/VENTILATION:

BUILDING NAME	NAME	LENGTH	HEIGHT	NOS
A (RESIDENTIAL)	V	0.60	0.90	04
A (RESIDENTIAL)	W1	0.90	1.20	02
A (RESIDENTIAL)	W	1.52	1.20	08

UnitBUA Table for Building :A (RESIDENTIAL)

FLOOR	Name	UnitBUA Type	UnitBUA Area	Carpet Area	No. of Rooms	No. of Tenement
GROUND FLOOR PLAN	SPLIT A	FLAT	184.73	183.98	8	1
FIRST FLOOR PLAN	SPLIT A	FLAT	0.00	0.00	8	0
Total:	-	-	184.73	183.98	16	1

LTP NAME AND SIGNATURE	STRUCTURAL ENG'S NAME AND SIGNATURE	BUILDER NAME AND SIGNATURE	DIGITAL SIGNATURE
KIRAN KUMARI JNP/ENG/0001/2019			