

TERRACE FLOOR PLAN (SCALE 1:100)

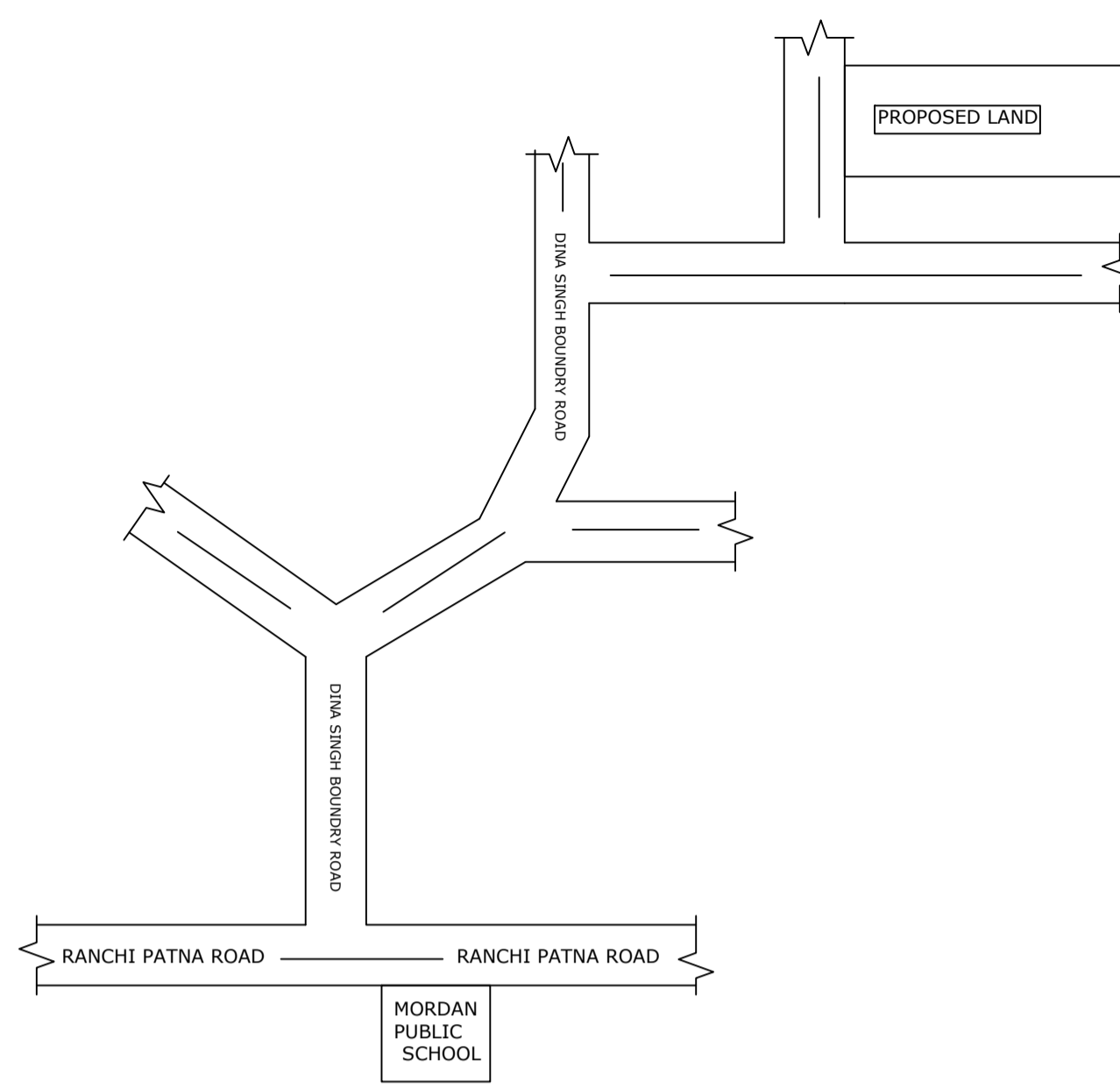

LOCATION PLAN (SCALE -1"8')

FAR & Tenement Details (Table 4c-1)

Building	Total Built Up Area (Sq.mt.)	Proposed FAR Area (Sq.mt.) Resi.	Total FAR Area (Sq.mt.)	Total Consumed Additional FAR Area (Sq.mt.)	Tnmt (No.)
A (RESIDENTIAL)	1	95.14	95.14	95.14	01
Grand Total :	1	95.14	95.14	95.14	01

Proposal Basic Information	
Proposal File No.	JNP/BP/0062/W07/2019
Owner Name	SMT. SANGITA KUMARI
Khata No	08
Plot No	39
Village Name	Jhalpo
Use	Residential
SubUse	Bungalow/ Dwelling / Non Apartment

PROJECT DETAIL:		VERSION NO. : 1.0.43	VERSION DATE: 29/04/2019
Region: JHARKHAND URBAN LOCAL BODIES	Plot Use: Residential		
District: KODERMA	Plot SubUse: Bungalow/ Dwelling / Non Apartment		
Authority: JHUMRITILAIYA NAGAR PARISHAD	PlotNearbyReligiousStructure: NA		
Inward No: JNP/BP/0062/W07/2019	PlotSubPlot No: 39		
Application Type: General Proposal	North: Plot No. - SRI SURESH PRASAD BARNWAL		
Project Type: Building Permission	South: Plot No. - SRI RADHE SYAM BARNWAL		
Nature of Development: New	East: Road Width - 3.6		
Location of Development Area: Old Area	West: Plot No. - SMT SITA DEVI		
AREA DETAILS:			SQ. MT.
AREA OF PLOT (Minimum)	(A)		81.26
NET AREA OF PLOT(Gross Plot Area - Deduction from Gross Plot area)	(A-Deductions)		81.26
Deduction for Balance Plot Area(from Gross Plot Area)			
Common Plot			10.65
Total			10.65
BALANCE AREA OF PLOT(Net Plot Area - Recreational/Amenity space)	(A-Deductions)		70.61
PLOT AREA FOR COVERAGE(Net Plot Area)	(A-Deductions)		81.26
Plot Area for FAR (Net Plot Area + Road/Widening Area)	(A-Deductions)		81.26
COVERAGE CHECK			
Permissible Coverage area (70.00 %)			56.88
Proposed Coverage Area (58.54 %)			47.57
Total Prop. Coverage Area (58.54 %)			47.57
Balance coverage area (11.46 %)			9.31
FAR CHECK			
Perm. FAR Area (1.50)			121.89
Total Perm. FAR area			121.89
Residential FAR			95.15
Proposed FAR Area			95.15
Total Proposed FAR Area			95.15
Consumed FAR (Factor)			1.17
Balance FAR Area			26.74
BUILT UP AREA CHECK			
Total Proposed BuiltUp Area			95.14
ARCHITECT (Regd)			KIRAN KUMARI
ENGINEER (Regd)			
SUPERVISOR (Regd)			
OWNER (Regd)			SMT. SANGITA KUMARI
DEVELOPMENT AUTHORITY			LOCAL BODY

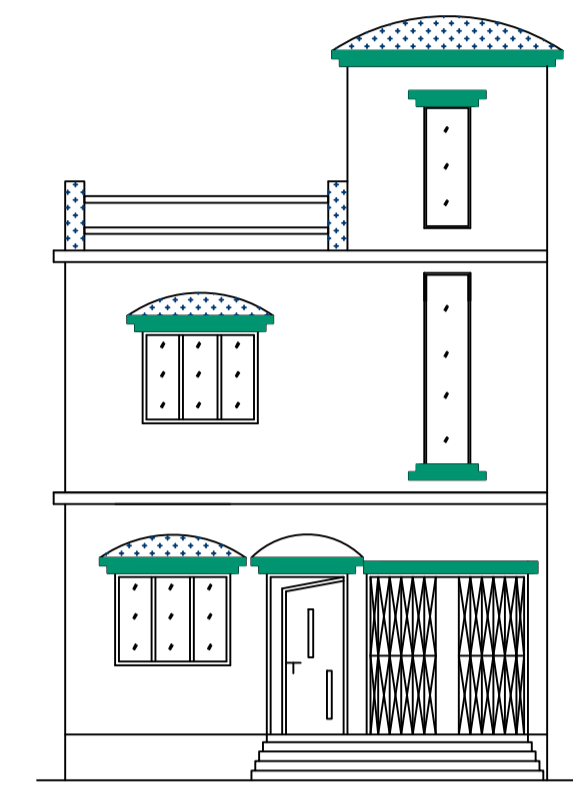

FRONT ELEVATION

SITE PLAN

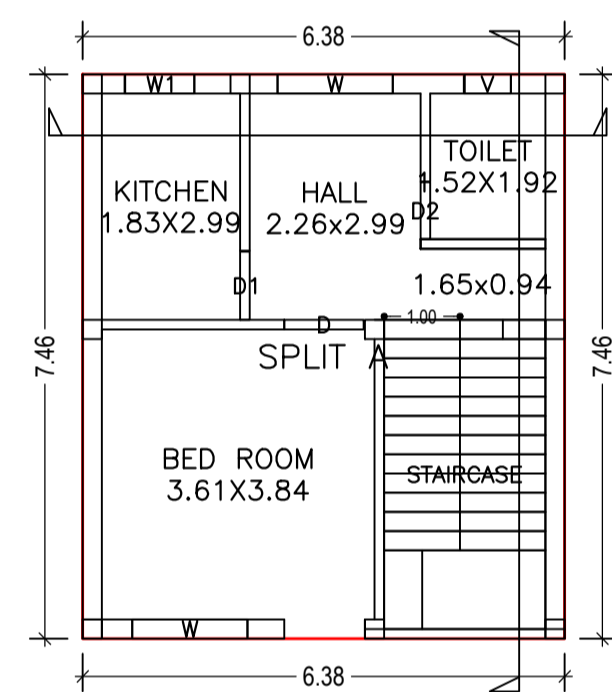

GROUND FLOOR PLAN (Proposed) (SCALE 1:100)

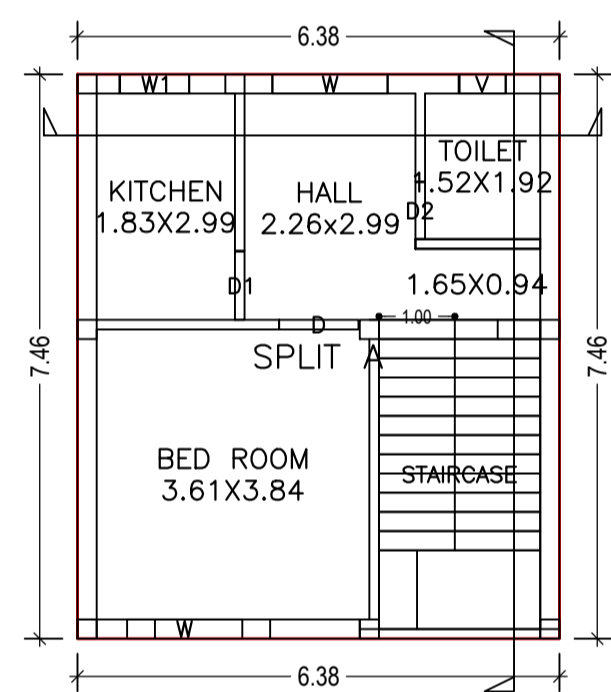

FIRST FLOOR PLAN (Proposed) (SCALE 1:100)

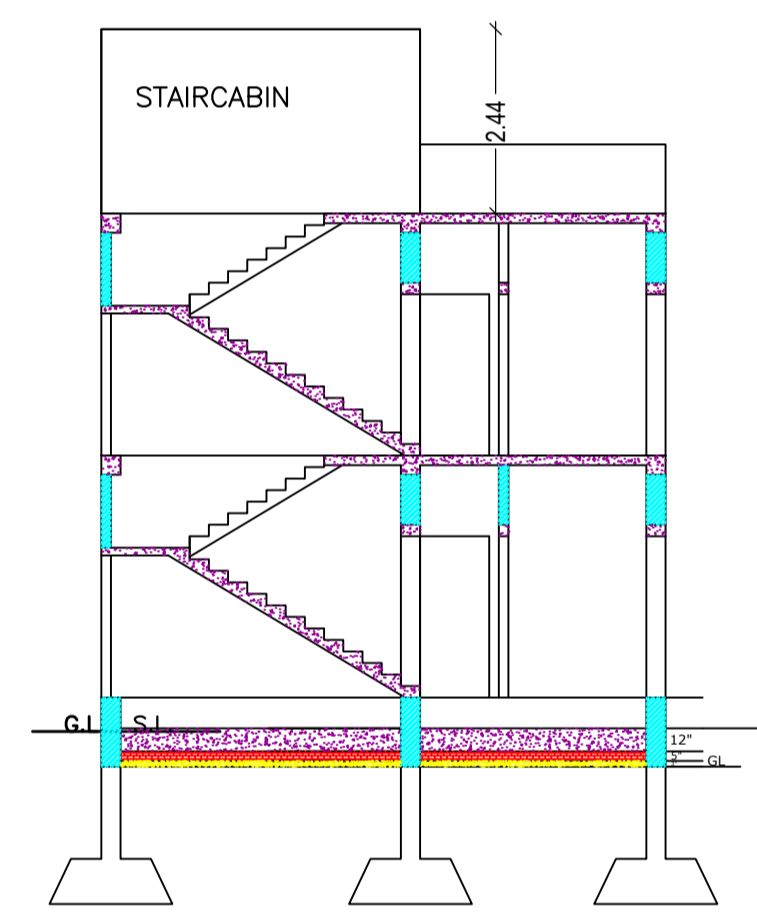

CROSS SECTION (A)

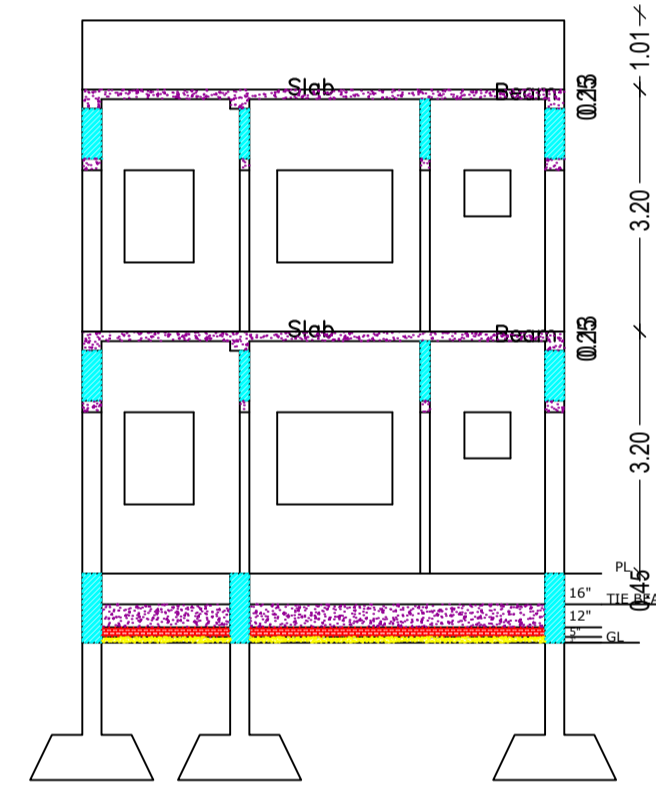

CROSS SECTION (B)

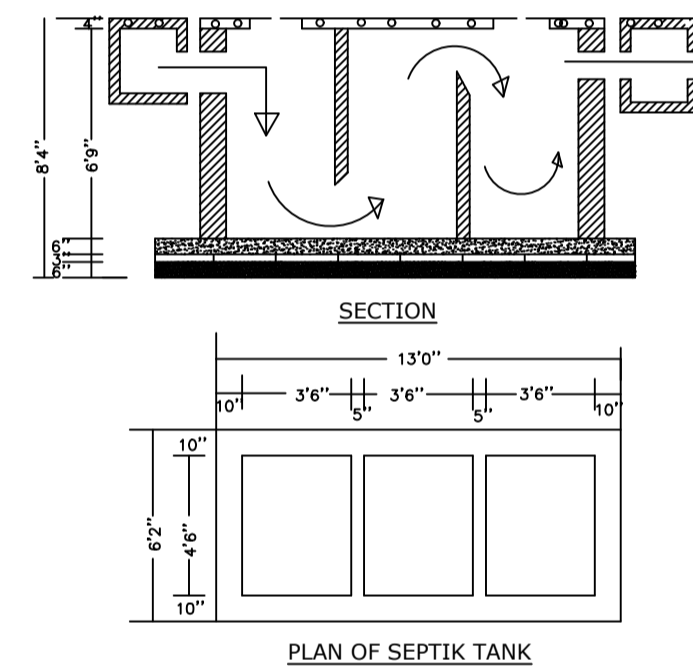

PLAN OF SEPTIK TANK

COLOR INDEX	
PLOT BOUNDARY	Black
ABUTTING ROAD	Green
PROPOSED CONSTRUCTION	Red
COMMON PLOT	Yellow
ROAD WIDENING AREA	Blue
EXISTING (To be retained)	Light Blue
EXISTING (To be demolished)	Light Yellow

Building :A (RESIDENTIAL)

Floor Name	Total Built Up Area (Sq.mt.)	Proposed FAR Area (Sq.mt.) Resi.	Total FAR Area (Sq.mt.)	Total Consumed Additional FAR Area (Sq.mt.)	Tnmt (No.)
Ground Floor	47.57	47.57	47.57	47.57	01
First Floor	47.57	47.57	47.57	47.57	00
Terrace Floor	0.00	0.00	0.00	0.00	00
Total :	95.14	95.14	95.14	95.14	01
Total Number of Same Buildings	1				
Total :	95.14	95.14	95.14	95.14	01

SCHEDULE OF DOOR:

BUILDING NAME	NAME	LENGTH	HEIGHT	NOS
A (RESIDENTIAL)	D2	0.75	2.10	02
A (RESIDENTIAL)	D1	0.90	2.10	02
A (RESIDENTIAL)	D	1.05	2.10	02

SCHEDULE OF WINDOW/VENTILATION:

BUILDING NAME	NAME	LENGTH	HEIGHT	NOS
A (RESIDENTIAL)	V	0.62	0.90	02
A (RESIDENTIAL)	W1	0.92	1.20	02
A (RESIDENTIAL)	W	1.52	1.20	04

UnitBUA Table for Building :A (RESIDENTIAL)

FLOOR	Name	UnitBUA Type	UnitBUA Area	Carpet Area	No. of Rooms	No. of Tenement
GROUND FLOOR PLAN	SPLIT A	FLAT	63.69	63.27	4	1
FIRST FLOOR PLAN	SPLIT A	FLAT	0.00	0.00	4	0
Total:	-	-	63.69	63.27	8	1

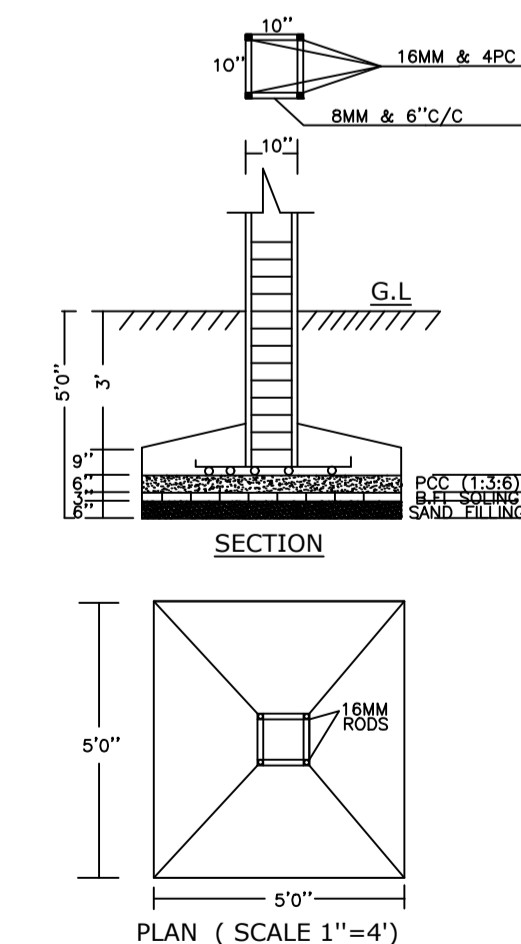

PLAN (SCALE 1"=4')

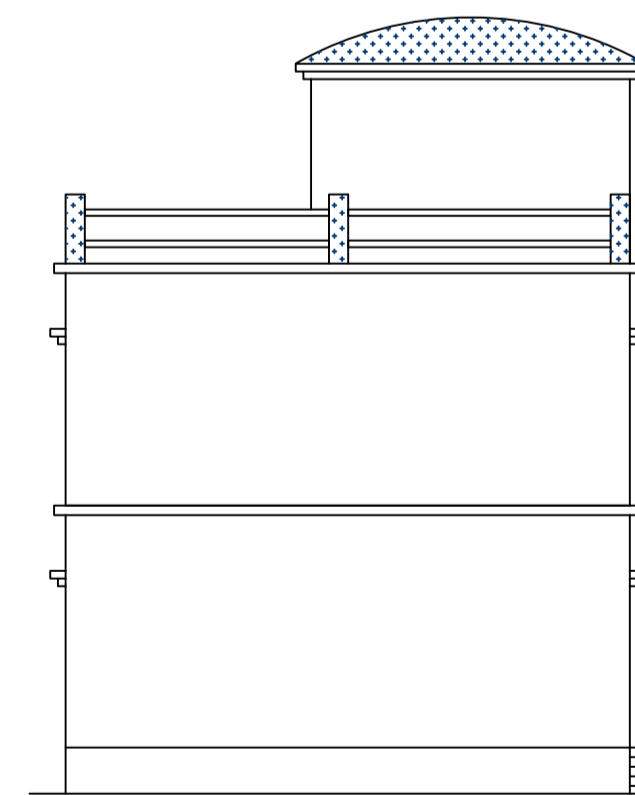

CROSS ELEVATION

Buildingwise Floor FAR Details

Floor Name	Building Name A (RESIDENTIAL)		Total	
	Proposed Built Up Area (Sq.mt.)	Proposed FAR Area (Sq.mt.)	Total Proposed Built Up Area (Sq.mt.)	Total FAR Area (Sq.mt.)
Ground Floor	47.57	47.57	47.57	47.57
First Floor	47.57	47.57	47.57	47.57
Terrace Floor	0.00		0.00	0.00
Total :		95.14	95.14	95.14

Building USE/SUBUSE Details

Building Name	Building Use	Building SubUse	Building Structure
	Residential	Bungalow/ Dwelling / Non Apartment	Non-Highrise

LTP NAME AND SIGNATURE	STRUCTURAL ENG'S NAME AND SIGNATURE	BUILDER NAME AND SIGNATURE	DIGITAL SIGNATURE
KIRAN KUMARI JNP/ENG/001/2019			